

ASSOCIATE EDITOR: ULF SIMONSEN

Human Experimental Pain Models for Assessing the Therapeutic Efficacy of Analgesic Drugs

Anne Estrup Olesen, Trine Andresen, Camilla Staahl, and Asbjørn Mohr Drewes

Mech-Sense, Department of Gastroenterology & Hepatology, Aalborg Hospital, Aarhus University Hospital, Aalborg, Denmark (A.E.O., T.A., A.M.D.); Grünenthal GmbH, R & D, Aachen, Germany (C.S.); and Center for Sensory-Motor Interaction, Department of Health Science and Technology, Aalborg University, Aalborg, Denmark (A.M.D.)

Abstract	724
I. Introduction	725
II. The pain system	725
A. Macro anatomy and mechanisms	725
1. Sensory nerves	725
a. Nociceptors in skin	725
b. Nociceptors in muscle and bone	726
c. Nociceptors in viscera	726
2. The spinal level	727
3. The supraspinal level	727
4. The sensitized pain system	729
B. Cellular and receptor level	729
1. Pain physiology	729
2. Plasticity and sensitization	730
III. Animal versus human pain models	732
IV. Clinical studies versus experimental human pain models	733
V. Experimental human pain models	734
A. Skin	734
1. Mechanical stimulation	734
a. Touch	735
b. Pinprick	735
c. Pressure	735
2. Electrical stimulation	735
3. Thermal stimulation	735
a. Cold	735
b. Contact heat	735
c. Laser	736
4. Models evoking hyperalgesia	736
a. Capsaicin	736
b. Nerve growth factor	737
c. Glutamate	737
d. Burn injury	737
e. Freeze lesion	737
f. Mustard oil	737
g. Menthol	738
h. Acid phosphate buffer	738
i. Sodium lauryl sulfate	738
j. Pinch	738
k. Electrical stimulation	738
B. Muscle and bone	738

Address correspondence to: Dr. Anne Estrup Olesen, Mech-Sense, Department of Gastroenterology & Hepatology, Aalborg Hospital, Mølleparkvej 4, 9000 Aalborg, Denmark. E-mail: aeo@mech-sense.com
This article is available online at <http://pharmrev.aspetjournals.org>.
<http://dx.doi.org/10.1124/pr.111.005447>.

1. Mechanical stimulation	739
a. Muscle	739
b. Bone	739
2. Electrical stimulation	739
3. Thermal stimulation	739
4. Models evoking hyperalgesia.	740
a. Ischemic stimulation	740
b. Exercise-induced muscle pain	740
c. Chemically induced muscle hyperalgesia	740
C. Viscera	741
1. Mechanical stimulation	741
2. Electrical stimulation	742
3. Thermal stimulation	742
4. Models evoking hyperalgesia	742
VI. Experimental pain modulation	743
A. Conditioned pain modulation	743
B. Summation	743
C. Thermal stimulation	743
D. Chemical stimulation	743
E. Long-term potentiation/depression.	744
VII. Pain assessment	744
A. Psychophysical methods	744
1. One-dimensional pain assessment tools	744
2. Multidimensional pain assessment tools.	744
B. Neurophysiological methods	745
1. Magnetic resonance imaging	745
2. Single photon emission computed tomography and positron emission tomography	745
3. Electroencephalography	745
4. Magnetoencephalography	746
C. The nociceptive withdrawal reflex	746
D. Referred pain area	746
VIII. Analgesic assessment by experimental human pain models in healthy volunteers	747
A. Nonopioids	747
1. Nonsteroidal anti-inflammatory drugs and acetaminophen	747
a. Acetylsalicylic acid (aspirin).	747
b. Ibuprofen	747
c. Ketorolac.	748
d. Acetaminophen (paracetamol)..	748
2. <i>N</i> -Methyl-D-aspartate antagonists.	749
a. Ketamine	749
3. Adjuvant analgesics.	750
a. Gabapentin and pregabalin	750
b. Lamotrigine	750
c. Imipramine.	751
B. Opioids	751
1. Short-acting opioids	751
a. Alfentanil and remifentanil	751
2. Longer acting opioids.	752
a. Traditional μ -receptor agonists	752
b. Opioids with weak affinity for the μ -opioid receptor	755
c. κ -Receptor agonists.	756
3. Opioids with mixed binding profile.	756
a. Tramadol.	756
C. Other types of analgesics	756
1. Cannabinoids.	756
a. Δ^9 -Tetrahydrocannabinol.	756

IX. Analgesic assessment by experimental human pain models in patients	757
A. Nonopioids	757
1. Nonsteroidal anti-inflammatory drugs and acetaminophen	757
a. Acetaminophen	757
b. Diclofenac, ibuprofen, and naproxen	757
c. Conclusions	757
2. <i>N</i> -Methyl-D-aspartate antagonists	758
a. Dextromethorphan	758
b. Ketamine	758
c. Conclusions	760
3. Adjuvant analgesics	761
a. Gabapentin and pregabalin	761
b. Conclusions	761
b. Amitriptyline	762
c. Imipramine	763
d. Fluoxetine	763
e. Conclusions	763
4. 5-Hydroxytryptamine-3 receptor antagonists	763
a. Alosetron	763
b. Granisetron	763
c. Ondasetron	764
d. Conclusions	764
B. Opioids	764
1. Short-acting opioids	764
a. Alfentanil	764
b. Meperidine	766
2. Longer acting opioids	766
a. Traditional μ -receptor agonists	766
b. κ -Receptor agonists	767
3. Opioids with mixed binding profile	767
a. Tramadol	767
4. Conclusions	767
X. Recommendations and conclusion	769
A. Conclusion	770
B. Perspectives	770
Acknowledgments	771
References	771

Abstract—Pain models in animals have shown low predictivity for analgesic efficacy in humans, and clinical studies are often very confounded, blurring the evaluation. Human experimental pain models may therefore help to evaluate mechanisms and effect of analgesics and bridge findings from basic studies to the clinic. The present review outlines the concept and limitations of human experimental pain models and addresses analgesic efficacy in healthy volunteers and patients. Experimental models to evoke pain and hyperalgesia are available for most tissues. In healthy volunteers, the effect of acetaminophen is difficult to detect unless neurophysiological methods are used, whereas the effect of nonsteroidal anti-inflammatory drugs could be detected in most models. Anticonvulsants and antidepressants are sensitive in several models, particularly in models inducing hyperalgesia. For opioids, tonic pain with

high intensity is attenuated more than short-lasting pain and nonpainful sensations. Fewer studies were performed in patients. In general, the sensitivity to analgesics is better in patients than in healthy volunteers, but the lower number of studies may bias the results. Experimental models have variable reliability, and validity shall be interpreted with caution. Models including deep, tonic pain and hyperalgesia are better to predict the effects of analgesics. Assessment with neurophysiologic methods and imaging is valuable as a supplement to psychophysical methods and can increase sensitivity. The models need to be designed with careful consideration of pharmacological mechanisms and pharmacokinetics of analgesics. Knowledge obtained from this review can help design experimental pain studies for new compounds entering phase I and II clinical trials.

I. Introduction

Chronic pain can have deleterious effects on health, employment, and daily life in the community (Smith et al., 2001). The prevalence of chronic pain in the adult population ranges from 2 to 40% with a median of 15% (Trescot et al., 2006). A higher prevalence of chronic pain among women (usually from musculoskeletal origin) has been reported (Ramage-Morin and Gilmour, 2010) and considerable costs for health systems, individuals, and society are associated with chronic pain (Reid et al., 2011).

Most of the knowledge on pain and pharmacology of pain has been obtained from studies in animals. However, the absence of verbal communication in animals is an obstacle to the evaluation of pain, and assessment can mainly be estimated by examining an animal's response (neurophysiological or behavioral) to nociceptive stimuli (Le Bars et al., 2001; Dolgin, 2010). Such data can only partly be interpolated to the human condition, which is a net result of complex sensory, affective, and cognitive processing. Furthermore, there are major differences between species that limit predictivity of animal models. Therefore, human experiments of pain pharmacology are highly warranted.

Our knowledge about human pain is based to a major degree on clinical studies. However, pain in patients is often blurred by other symptoms, and sedative properties of some analgesics make evaluation difficult. Experimental methods to evoke and assess pain under controlled circumstances are advantageous because they encompass many of these problems and offer a unique opportunity to investigate analgesic effects on different pain modalities arising from different tissues as well as peripheral and central pain mechanisms (Drewes et al., 2003; Staahl et al., 2006b; Arendt-Nielsen and Yarnitsky, 2009).

In human experimental pain models, the evoked sensations can be assessed with subjective methods quantitatively (e.g., by using a visual analog scale) and qualitatively (e.g., by using the McGill Pain Questionnaire), and stimulus-response relationships can be investigated. Objective, physiological responses for the pain can also be recorded with, for example, the nociceptive reflex, cerebral evoked potentials, and imaging.

In this review, pain physiology and mechanisms are first described, followed by a discussion of differences between animal and human studies of pain. Next, differences between human experimental pain studies and clinical pain studies in patients are outlined, followed by a comprehensive review of human experimental pain models, including superficial models, deeper pain models, and models of hyperalgesia. We then provide review of various pain assessment methods and pain modulation methods; finally, results from studies testing different analgesics in healthy volunteers and pa-

tients by experimental pain models are reviewed and discussed.

II. The Pain System

A. Macro Anatomy and Mechanisms

As opposed to the traditional views of pain as a "hard wired" system, pain is now seen as a dynamic system that undergoes plastic changes. Hence, the complexity of the pain system is a result of modulation of afferent activity via peripheral and central mechanisms, although it is normally described in a simplified way, as in Fig. 1.

Information regarding pain and analgesic mechanisms can be obtained from 1) *In vitro* studies, 2) animal experiments, 3) experimental pain studies (healthy volunteers and patients), 4) observational clinical studies, and 5) interventional clinical studies. As individual sources of information, each of them is inadequate and limited by several biases (see section III), but in combination they have increased our information on the pain system and analgesic mechanisms substantially. In the following section, the most important data from such studies are used to give the reader a short introduction to the pain system. For more detailed information on the pain system the reader is referred to, for example, Meyer et al. (2005).

1. Sensory Nerves. Pain occurs when nociceptors are stimulated by, for example, chemical, thermal, or mechanical stimulation. Nociceptors are nerve endings that respond to potentially damaging stimuli by sending signals to the spinal cord and brain. They are located in skin, internal organs, joints, muscles, and tendons. All nociceptive fibers terminate as free nerve endings (Stacey, 1969). There are two kinds of nociceptive pain: somatic and visceral. Somatic pain occurs when skin, muscle, or bone is damaged, whereas visceral pain originates in the internal organs. Activation of receptors in the nerve endings results in a graded action potential reflecting the stimulus intensity (Julius and Basbaum, 2001). When peripheral sensory fibers (primary afferent fibers) respond to noxious stimuli, they transmit this information through the dorsal root ganglion to the dorsal horn of the spinal cord. From here, projection neurons activate higher brain centers and pain information reaches consciousness (D'Mello and Dickenson, 2008).

a. Nociceptors in Skin. In human skin, there are three main types of primary afferent fibers ($A\beta$, $A\delta$, and C fibers), each of which has different properties, allowing them to respond to different types of sensory information (D'Mello and Dickenson, 2008). Large and myelinated $A\beta$ fibers are normally not involved in pain transmission but respond to light touch and convey tactile information. $A\delta$ fibers are thinly myelinated nerves transmitting stimuli (more slowly than $A\beta$ fibers; 5–30

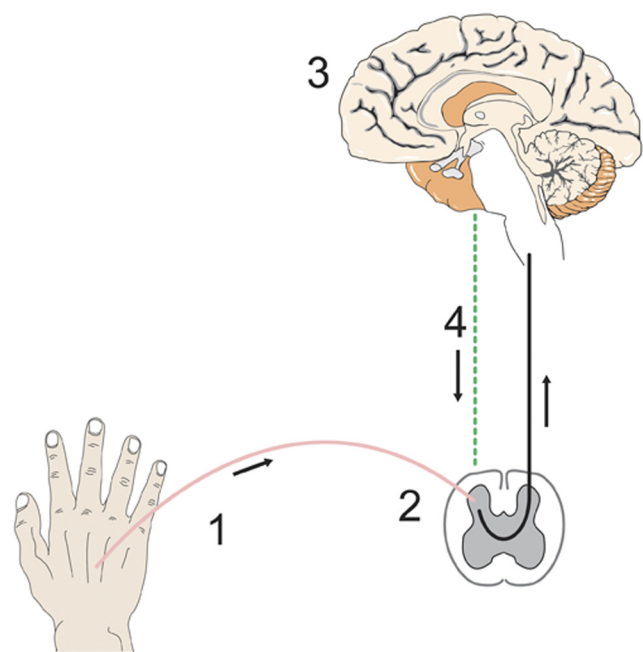

FIG. 1. Pain signaling. The pain signals are encoded by peripheral nociceptors and information is led via afferent nerves (1) to the spinal cord. The afferent barrage activates neurons in the spinal cord (2) and the information is led to supraspinal centers (3). In addition, the brain can modulate the incoming activity via descending control systems (4).

m/s) to the central nervous system (CNS¹). They respond to mechanical stimulation, especially pinching or pinprick. In the skin, A δ fibers are mainly specialized for detection of potentially dangerous mechanical and thermal stressors and for triggering a rapid response and protective reflexes (Byers and Bonica, 2001). The fibers also play an important role in hyperalgesia (Craig, 2003). C fibers are thin and nonmyelinated nerves that transmit stimuli more slowly (less than 1 m/s) than A fibers. They constitute the majority of nociceptors. They respond to strong mechanical, thermal, or chemical stimuli. They are mainly polymodal, but some are specialized for detecting a single stimulus as heat or pinch. Moreover, there are “silent” sensory fibers that do not respond to high-intensity stimulation under normal conditions but are spontaneously activated and respond to innocuous stimuli under inflammatory conditions (Mi-

¹Abbreviations: 5-HT, 5-hydroxytryptamine (serotonin); AMPA, α -amino-3-hydroxy 5-methyl-4-isoxazolopropionic acid; CB, cannabinoid; CGRP, calcitonin gene-related peptide; CNS, central nervous system; CPM, conditioned pain modulation; DNIC, diffuse noxious inhibitory control; DOMS, delayed onset muscle soreness; EEG, electroencephalography; EP, evoked potential; fMRI, functional MRI; GI, gastrointestinal; IBS, irritable bowel dysfunction; IL, interleukin; LTD, long-term depression; LTP, long-term potentiation; MEG, magnetoencephalography; MRI, magnetic resonance imaging; NGF, nerve growth factor; NK1, neurokinin 1; NMDA, *N*-methyl-D-aspartate; NSAID, nonsteroidal anti-inflammatory drug; PET, positron emission tomography; RVM, rostral ventromedial medulla; SLS, sodium lauryl sulfate; SP, substance P; SPECT, single photon emission computed tomography; TRP, transient receptor potential cation channel; TRPV1, transient receptor potential cation channel vanilloid type 1; VAS, visual analog scale.

chaelis et al., 1996). For detailed information, see Byers and Bonica (2001).

b. Nociceptors in Muscle and Bone. The clinical features of muscle pain are different from skin pain, because muscle pain is a cramp-like, aching, and diffuse pain whereas skin pain is more localized. Pain from deep structures (muscle, bone, and viscera) has traditionally been little investigated compared with pain of somatic origin (Ness, 1995). The lack of studies contrasts the fact that deep pain is the most frequent in the clinic. The different diseases giving rise to deep pain can be difficult to diagnose and the clinical picture is often blurred by coexisting symptoms and the presence of referred pain (see section II.A.2). This is partly explained by the sparse and diffuse termination of nociceptive afferents at the spinal level (reflecting the diffuse and nonspecific pain characteristics) together with the interaction between, for example, afferents from deep tissue and the somatic and autonomic nervous systems (Fig. 2). The majority of A δ and C fibers (in muscles also labeled type II and IV) serve as polymodal nociceptors (Cairns, 2008).

The periosteum of the bone is a frequent site of pain and is also innervated by A δ and C fibers. The terminals of these fibers mostly contain polymodal receptors (Byers and Bonica, 2001). The periosteum is therefore very sensitive to a variety of stimuli where mechanical activation is the most clinically relevant (Bonica and Loeser, 2001).

c. Nociceptors in Viscera. The neural information from visceral organs does not normally reach higher brain centers, except, for example, information regarding the filling of the esophagus, stomach, and rectum. However, when the organs are potentially in danger (e.g., because of disease), symptoms such as discomfort and pain are reported. Because of the diffuse spinal organization (see section II.A.2) these symptoms are typically vague and difficult to characterize. Visceral afferent fibers are either nonmyelinated C fibers (70–90%) or thinly myelinated fibers belonging to the A δ class. Most visceral nociceptors are nonspecific (polymodal) and respond to many different kinds of stimuli (for more extensive review, see Cervero, 1994; Sengupta and Gebhart, 1994; Knowles and Aziz, 2009; Olesen et al., 2009c). The peritoneum and parietal serous membranes of the lungs and heart have their own parietal nerve supply, which is organized like the skin (Fig. 2). Hence, pain from these structures gives a distinct, intense, and localized pain comparable with the pain evoked by skin lesions. The visceral afferents, mediating conscious sensations, run predominantly together with nerves belonging to the sympathetic nerves, although some nociceptive afferents join parasympathetic and other pathways (Fig. 2). This complex anatomy creates the possibility for cross-talk with the autonomic nervous system at both peripheral and central levels (Jänig et al., 1993). The enteric nervous system is also closely

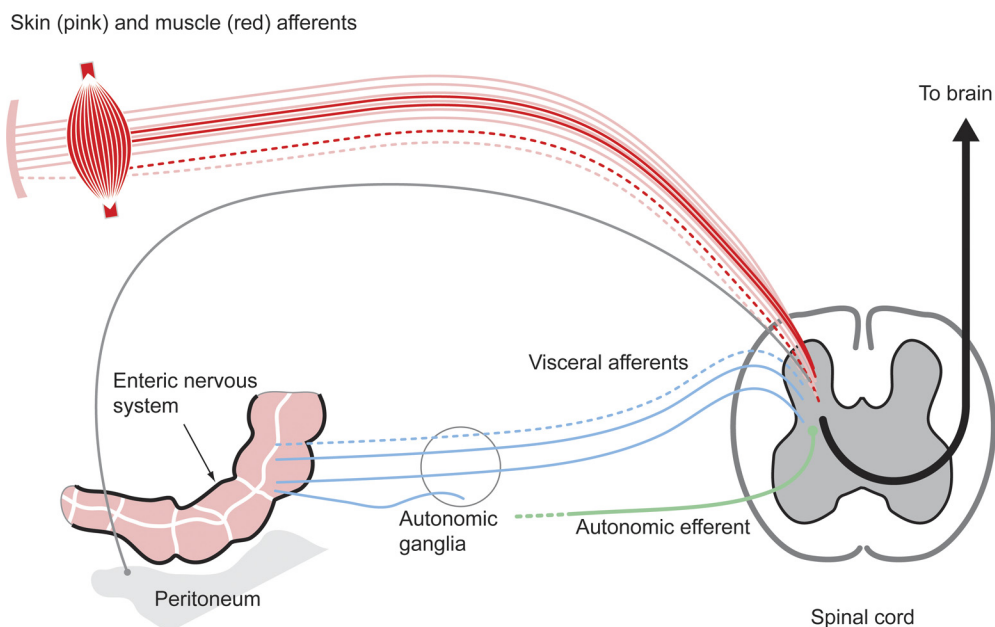

FIG. 2. The afferent nerves of the pain system. Multiple afferents from the skin (pink) travel to the spinal cord via distinct nerve trunks, whereas afferents from muscle (red) are sparser but still well defined. Visceral afferents (blue) from the gut and other organs travel temporarily together with either the sympathetic or the parasympathetic nerves. These afferents primarily project to the spinal cord or brain stem, but because of the close relation to autonomic nerves, they can also “cross-talk” with the autonomic or enteric nervous systems through local or spinal reflexes via autonomic efferents. This may result in, for example, muscle contractions or changes in gut motility. During inflammation, “silent afferents” (dashed lines) may become activated. The peritoneum has its own parietal nerve supply organized as the somatic nervous system, and when these nerves become activated, the pain can change in nature and localization.

related to the nociceptive afferents and is considered a subdivision of the autonomic nervous system. It has been demonstrated that both pain and the autonomic nervous system can modulate the functions of the enteric nervous system, resulting in motility changes, nausea, and altered secretion/absorption of the gut, which can dominate the clinical picture (Wood et al., 1999).

2. The Spinal Level. Transmission of stimuli from periphery to the brain travels through the spinal cord. In the spinal cord, incoming sensory and nociceptive signals undergo convergence and modulation (D’Mello and Dickenson, 2008) (for details about spinal organization, see Terman and Bonica, 2001; D’Mello and Dickenson, 2008). The spinal cord contains various neuronal cell types connecting with the primary afferents. Some neurons are nociceptive-specific, whereas others are termed wide dynamic range neurons and receive input from all three types of sensory fiber. They respond to a full range of stimulation from light touch to noxious stimuli. Wide-dynamic-range neurons fire in a graded fashion depending on stimulus intensity and also exhibit “wind-up,” which is a short-term increase in the excitability of dorsal horn neurons after repeated stimulations of the afferents with the *same intensity* (D’Mello and Dickenson, 2008). The wind-up phenomenon results in amplification of the pain response, and part of this phenomenon is used in experimental human pain because it mimics pain mechanisms in neuropathic and chronic pain (see section VI). Excitatory or inhibitory interneurons are also found in the dorsal horn, and these are influenced by higher brain centers

(see section II.A.3). The brain can therefore modulate the response of neuronal activity from the periphery (D’Mello and Dickenson, 2008).

Pain originating from muscle and viscera is typically felt in somatic areas remote from the stimulus (referred pain). This is seen, for example, in acute cholecystitis, where patients report pain referral to the right shoulder, or in patients suffering from cardiac ischemia, where pain is referred to the left arm or to the chin (Fig. 3). Convergence between, for example, visceral and somatic afferents traveling from the periphery at second order neurons in the spinal cord seems to be important. However, the neural mechanisms are far more complex (for details, see Arendt-Nielsen et al., 2000a).

Viscero-visceral hyperalgesia where, for example, acidification of the esophagus results in widespread changes in the perception of pain from remote organs, such as the rectum, is another complex form of hypersensitivity (Frøkjær et al., 2005; Brock et al., 2009a). This is probably explained by more than one mechanism, but it is plausible that central sensitization plays an important role. These changes in pain perception also involve changes in cortical processing of pain (Sami et al., 2006).

3. The Supraspinal Level. The output from the dorsal horn in the spinal cord to higher brain centers is conveyed by spinal projection neurons (D’Mello and Dickenson, 2008). An extensive cortical network associated with pain processing has been revealed and is increasingly recognized as playing a major role in the representation and modulation of pain. These areas

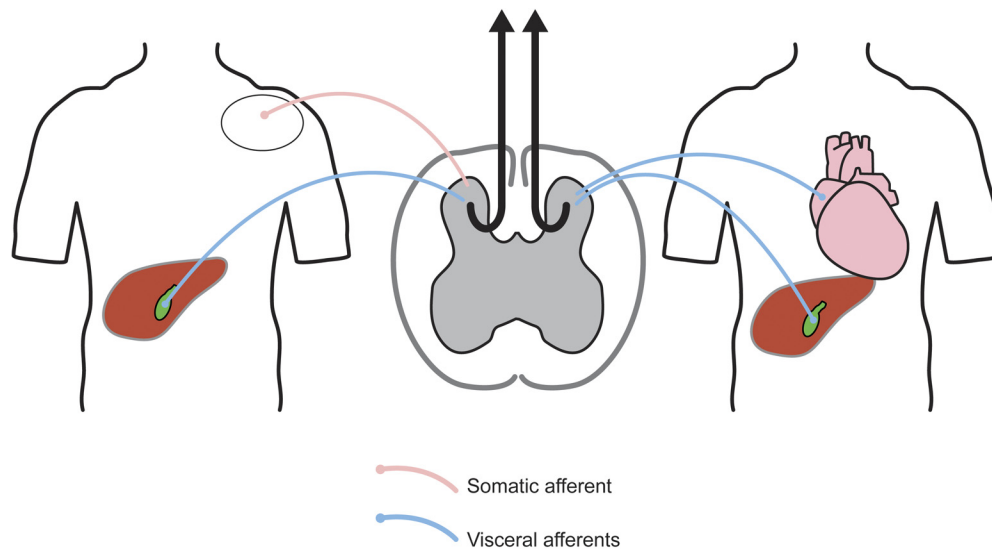

FIG. 3. Referred pain. Most visceral afferents converge with neurons that receive input from superficial and deep somatic tissue resulting in “referred pain.” Pain referral to somatic areas remote from the visceral organs is a common finding in visceral diseases [e.g., pain referral to the right shoulder in acute cholecystitis (left)]. Viscerovisceral convergence on spinal neurons receiving afferent supply from different viscera may present as visceral allodynia in areas remote from the original lesion. This may present as, for example, increased pain intensity during gallstone attacks in patients with background pain from ischemic heart disease (right).

are termed the pain matrix (Iannetti and Mouraux, 2010) and most often include the primary somatosensory cortex, secondary somatosensory cortex, the anterior cingulate cortex, prefrontal cortex, insular cortex, and other limbic structures, such as the amygdala

(Fig. 4) (Apkarian et al., 2009; Iannetti and Mouraux, 2010).

The brain controls a complex network that is able to modulate the incoming activity from primary afferents, and this network may undergo pharmacologic modula-

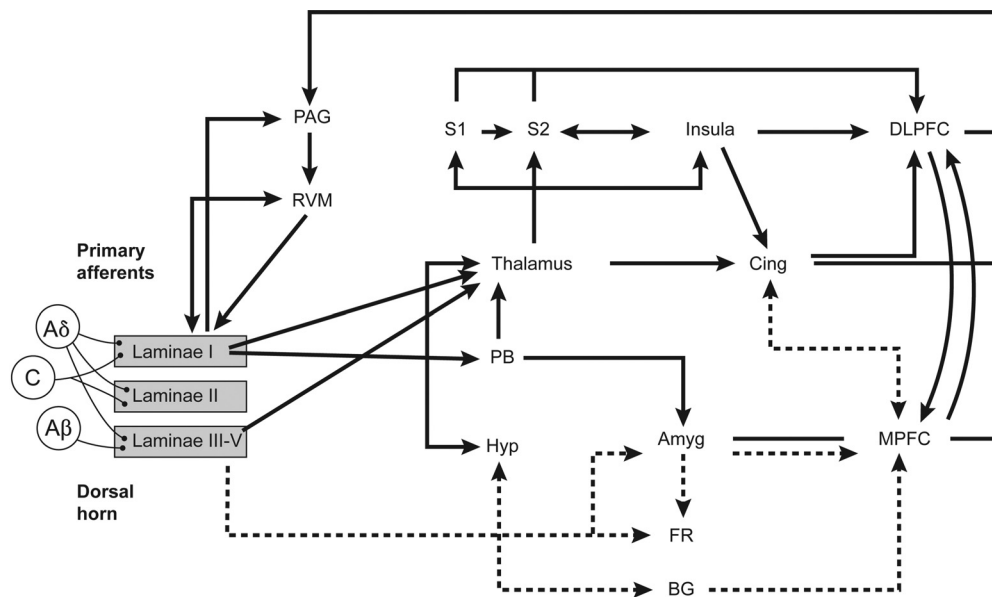

FIG. 4. Main subcortical and cortical areas involved in pain processing and the connectivity between them. Primary afferents ($A\delta$, C, and $A\beta$ fibers) transmit impulses from the periphery through the dorsal root ganglion to the dorsal horn of the spinal cord. Most nociceptive $A\delta$ and C fibers terminate superficially in laminae I and II, but also project either directly ($A\delta$ fibers) or poly synaptically (C fibers) to lamina V, whereas $A\beta$ fibers terminate predominantly in laminae III to V. In the dorsal horn, the primary afferents connect with various neuronal cell types that project to different areas of the central nervous system. Neurons from lamina I project mainly to the periaqueductal gray (PAG), RVM, thalamus and parabrachial nucleus (PB). Neurons found in the deeper laminae III to V also project to the thalamus as well as to the formatio reticularis (FR) of the brainstem. Dotted lines represent the interaction between basal ganglia (BG), amygdala (amyg), and medial prefrontal cortex (MPFC), which constitutes the emotional, affective, and motivational components hypothesized to play an important role in chronic pain. Solid lines represent the areas involved in sensory-discriminative processing of pain and the connectivity between them—thalamus, cingulate cortex (cing), primary and secondary somatosensory cortices (S1 and S2), insula, and dorsolateral prefrontal cortex (DLPFC), hypothesized to play a role in acute pain. These areas then project to PAG, which in turn indirectly controls pain transmission in the dorsal horn through RVM and descending facilitatory or inhibitory pathways modulating spinal cord activity. [Modified from Apkarian AV, Baliki MN, and Geha PY (2009) Towards a theory of chronic pain. *Prog Neurobiol* 87:81–97. Copyright © 2009 Elsevier Ltd. Used with permission.]

tion. Hence, the subjective pain perception is a dynamic balance of bidirectional pain-control mechanisms (Fields et al., 2006). It has now become clear that several mechanisms contribute to the inhibition (or facilitation) of pain signals coming from the periphery (Le Bars, 2002). For simplicity, four different regions within the CNS contribute to pain control:

1. Segmental spinal inhibition (modified gate control), which involves interneurons located in the dorsal horn (Maxwell et al., 2007).
2. Diffuse noxious inhibitory control (DNIC), which operates through heterotopic conditioning stimulation and involves a spino-bulbo-spinal loop, including the dorsal reticular nucleus (Le Bars, 2002).
3. Inhibition through the brainstem network, consisting of centers in periaqueductal gray and rostral ventromedial medulla, which possesses modulating abilities through ON cells and OFF cells (pronociceptive or antinociceptive, respectively) (Heinricher and Morgan, 1999).
4. Top-down control, where the role of cognitive and affective cortical centers seems to play a role (Moont et al., 2010).

DNIC is a phenomenon known from animals that can be experimentally induced. Nevertheless, in humans, the modulatory pain pathways are more complex, and it is now referred to as conditioned pain modulation (CPM) (Yarnitsky, 2010) (see section VI.A).

4. The Sensitized Pain System. Sensitization of the nervous system includes both peripheral and central components. An injury in the periphery results in release of numerous inflammatory mediators, described in section II.B. These mediators activate and sensitize terminals of primary afferents (Curatolo et al., 2006). The activated fibers develop ongoing activity and display major changes in receptive fields and patterns of referral within minutes after tissue irritation. This condition leads to increased afferent activity in the spinal cord and exacerbates pain.

Pain resulting from nerve damage is another entity. Neuropathic pain is defined as “pain arising as a direct consequence of a lesion or disease affecting the somatosensory system” (Treede et al., 2008). Neuropathic pain may develop for months or years after injury and, unlike nociceptive pain, it is often chronic and does not require a stimulation of specific pain receptors (Pazzaglia and Valeriani, 2009). With neuropathic pain, the function of the nerves typically becomes compromised and their activity increases (see section II.B.2). Although many mechanisms come into play, those in the CNS are of outmost importance. The abnormal activity causes other nerves to become ultrasensitive, leading to altered responses to perceived sensations, such as allodynia or hyperalgesia. Although neuropathic pain has mostly been described in the skin, diseases and lesions of the muscle and viscera may also give neuropathic pain (Drewes et al., 2008).

B. Cellular and Receptor Level

This section is not a complete review of the microstructural pain system (see, for example, McMahon and Koltzenburg, 2006), but focuses mainly on the mechanisms by which exogenous modulation is possible and has been investigated in human experimental pain.

1. Pain Physiology. The physiochemical properties of noxious stimuli are converted to electrical activity by, for example, the transient receptor potential-generating channels (TRP channels) and purinergic channels. The electrical activity formed is then amplified by sodium, potassium, and calcium channels to elicit action potentials that travel to the central nervous system (Kuner, 2010) (Fig. 5).

The importance of ion channel subtypes will not be described in detail here, because extensive literature on this topic exists (Krishnan et al., 2009; Zamponi et al., 2009). As described above, sodium channels generate action potentials, and they can be seen as the accelerator of nociceptive messaging (Harvey and Dickenson, 2008). Potassium channels act as a brake in the system and prevent repetitive firing and after-firing (Rivera-Arconada et al., 2004; Krishnan et al., 2009) (Fig. 5). Voltage-gated calcium channels are expressed mainly at presynaptic nerve terminals, where they open in response to incoming action potentials and mediate calcium entry into the synapse. This in turn triggers synaptic vesicle release, which results in action potentials traveling to the brain via activation of receptors in second-order neurons (Fig. 6).

When the electrical signal travels to the spinal synapse, the change in membrane potential elicits release of neurotransmitters such as glutamate and substance P (Todd et al., 2000). These neurotransmitters mediate nociceptive signaling in the spinal cord through activation of various receptors. The most important are α -amino-3-hydroxy 5-methyl-4-isoxazolepropionic acid (AMPA) and *N*-methyl-D-aspartate (NMDA) receptors, but kainate receptor also plays a role (Dickenson, 1995). Glutamate is the predominant excitatory transmitter used by primary afferent synapses and intrinsic neurons in the spinal cord dorsal horn. Accordingly, ionotropic glutamate receptors mediate basal spinal transmission of sensory (including nociceptive) information that is relayed to supraspinal centers (Larsson, 2009). However, metatropic glutamate receptors also are activated (Harvey and Dickenson, 2008). Schematic illustrations of the peripheral and spinal mechanisms are given in Figs. 5 and 6.

Despite solid knowledge of the structures engaged in pain transmission, the cerebral mechanisms involved in pain modulation are still not completely understood. Multiple neurotransmitters including opioid, glutamate, GABA, and dopamine transmitters are involved in the modulation of pain by these cortical structures (Xie et al., 2009).

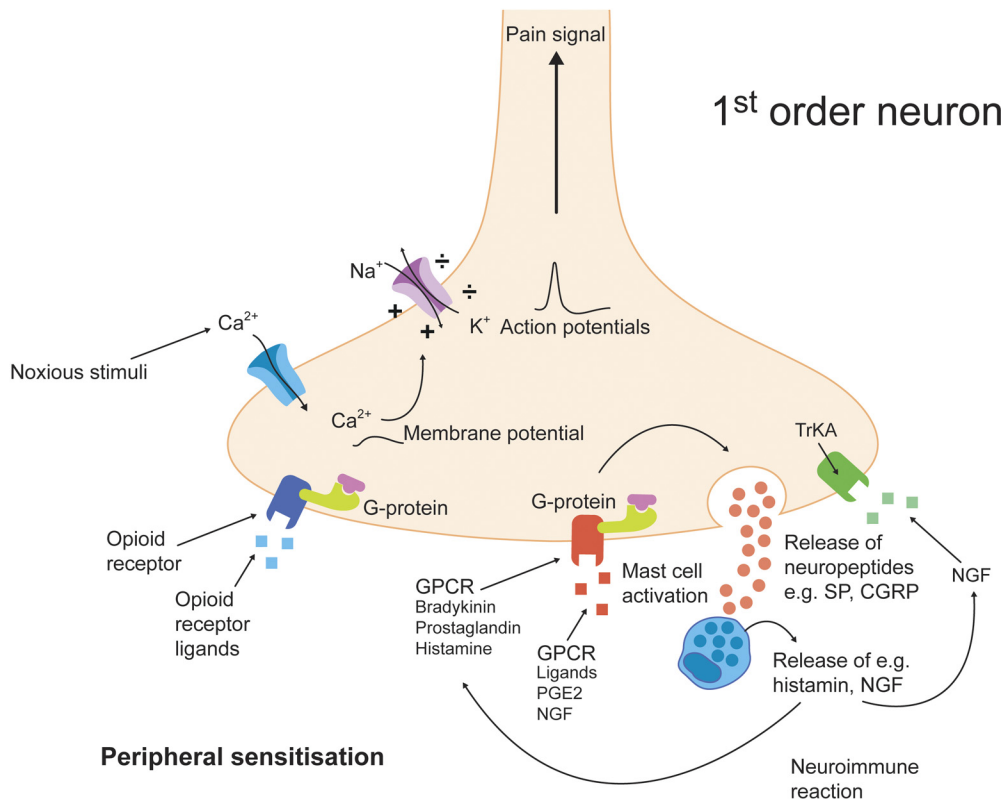

FIG. 5. Properties of nociceptor sensitization in the periphery. A noxious stimulus of, for example, thermal, chemical, or mechanical origin is converted into an electrical signal amplified by calcium and sodium channels to elicit action potentials that travel to the central nervous system. After an injury, mast cells close to the nerve terminal are activated. This leads to release of inflammatory mediators such as histamine, NGF, prostaglandin, and bradykinin. These act on receptors such as G-protein-coupled receptors (GPCR) and tyrosine kinase receptor type 1 (TrKA) expressed on the nociceptor nerve terminals, leading to peripheral nociceptor sensitization. Furthermore, there is release of neuropeptides (e.g., SP and CGRP), resulting in interaction between immune cells and nociceptors. PGE2, prostaglandin E2.

2. *Plasticity and Sensitization.* Molecules may change in an activity-dependent manner (for example, by phosphorylation) and thereby alter their function (for example, a drop in the activation threshold of an ion channel) or localization (for example, endocytosis or trafficking) (Liu and Salter, 2010). However, differential expression of a receptor also can cause a change in the nociceptive signaling process (Liu and Salter, 2010; Mucha et al., 2010). An injury in the periphery results in a release of numerous inflammatory mediators, such as histamine, serotonin, substance P, and prostaglandins (Fig. 5). Some inflammatory mediators directly activate the nociceptors, evoking pain, whereas others sensitize the pain system. This is typically seen in inflammation, enabling easier activation of the pain system in the presence of an injury (Scholz and Woolf, 2002). After damage to peripheral nerves, primary afferent fibers can display aberrant “ectopic” activity. This can alter their pattern of excitability and conduction, causing neuropathic spontaneous pain and hyperalgesia that maintains central sensitization (Aurilio et al., 2008; Harvey and Dickenson, 2008). It is believed that one of the key molecular mechanisms is abnormal modulation of voltage-gated sodium channels in the soma and axonal membranes of dorsal root ganglion sensory neurons (Sillos-Santiago, 2008).

Peripheral injury can produce central neuronal changes that are maintained even after the inputs from the injury are removed. Neurophysiological, central sensitization is characterized by increased spontaneous activity, decreased firing threshold, and expansion of the receptive fields of dorsal horn neurons (Coderre et al., 1993). The alterations in functional structure may result in central plasticity, hyperexcitability, and “pain memory,” which after some time may be consolidated and independent of the original peripheral input (Coderre et al., 1993). A widely acknowledged cause of sensitization is the postsynaptic mechanisms of synaptic potentiation via activation of the NMDA receptor, where potentiation results in amplified excitatory postsynaptic potentials (Liu and Salter, 2010).

Once signals have entered the dorsal horn of the spinal cord, they are modulated by inhibitory processes operated both by local inhibitory interneurons acting presynaptically on transmitter release and postsynaptically on relay neuron excitability. The main local inhibitory transmitter is GABA (Hill, 2001). However, cannabinoids, enkephalins, and adenosine also play an important role here (see Fig. 6) (Kuner, 2010).

The opioid system is a major component of the body’s ability to suppress pain. Most centers involved in descending control are rich in opioid receptors (Pinto et al.,

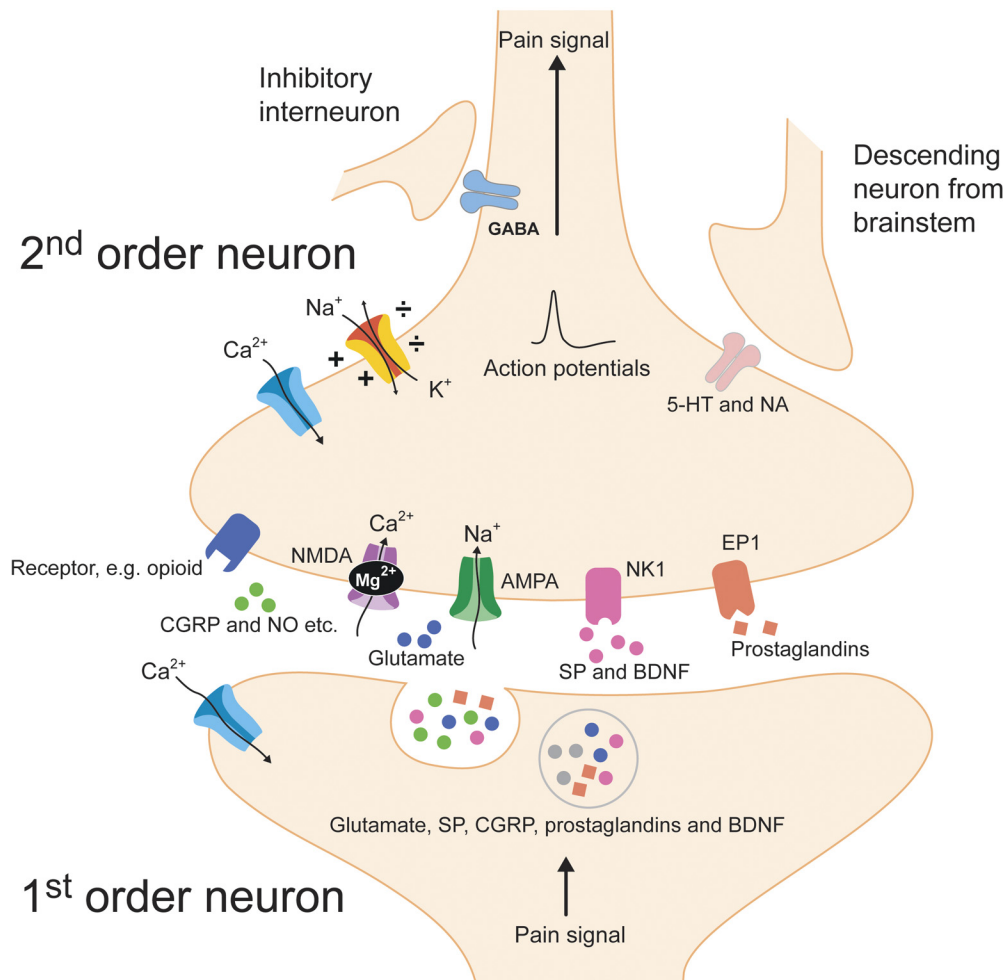

FIG. 6. Simplified representation of the spinal transmission. Central terminals of primary nociceptor afferents release the neurotransmitters glutamate, SP, CGRP, nitric oxide (NO), prostaglandins (PG), and brain-derived neurotrophic factor (BDNF). Normally, excitatory amino acids such as glutamate bind to metabotropic glutamate specific receptors and ionotropic AMPA receptors. SP and BDNF bind to the G-protein-coupled NK1 receptor and the tyrosine kinase receptor B, and prostaglandins binds to the EP1 receptor on the postsynaptic membrane. This results in transmission of the nerve signal from first-order to second-order neurons. In the sensitized state, ligand-gated ion channels such as NMDA receptors are up-regulated, and the magnesium plug is removed, increasing glutamate sensitivity so that signaling is intensified. An increase in intracellular Ca²⁺ concentrations is the major trigger for the activation of protein kinases that phosphorylate the AMPA receptors, leading to a potentiation in activity. Inhibitory interneurons that normally signal via GABA and glycinergic receptors are also lost, causing less activation of, for example, μ -opioid receptors and α_2 adrenergic receptors, among others. Inhibitory (or facilitatory) pathways descending from the brainstem mainly release neurotransmitters in the spinal cord, especially serotonin (5HT) and noradrenaline (NA) or activate small opioid-containing interneurons in the spinal dorsal horn to release opioid peptides. In the sensitized state, the descending inhibitory pathways from the brain are less activated.

2008), and opioids therefore play an important role in the brain's pain control systems. The three main receptor subtypes, μ , δ , and κ , all have endogenous ligands (Roques et al., 1999; Fioravanti and Vanderah, 2008). These receptors are located on the primary afferents, in the spinal cord, and in the brain. The peripheral receptors are mainly important when inflammation is present (Stein, 1993; Stein et al., 1999; Labuz et al., 2007; Trescot et al., 2008). The μ receptor is the most abundant in the spinal cord and is the main modulator of the pain system, although δ and κ receptors seem to play a role during, for example, sensitization (Minami and Satoh, 1995). Activating opioid receptors results in indirect inhibition of voltage-dependent calcium channels, decreasing cAMP levels and blocking the release of pain neurotransmitters such as glutamate, substance P (SP),

and calcitonin gene-related peptide (CGRP) from the nociceptive fibers, resulting in analgesia (Trescot et al., 2008). Figure 7 is a simplified illustration of opioid mechanisms in CNS (Fig. 7).

At postsynaptic sites, the opioids open potassium channels via activation of distinct G protein-coupled receptors and hence dampen the excitability of the nerve cells (Dickenson, 1995). Opioids exert complex effects in the brain, where they bind to receptors in a variety of structures. The most important are prefrontal cortex, cingulate cortex, midbrain periaqueductal gray and rostral ventral medulla. The net action is an increase of the descending inhibition via a shift of activation of the ON and OFF cells in the rostral ventral medulla. The descending pathways release either noradrenaline or serotonin, in the end leading to modulation of the pain signal

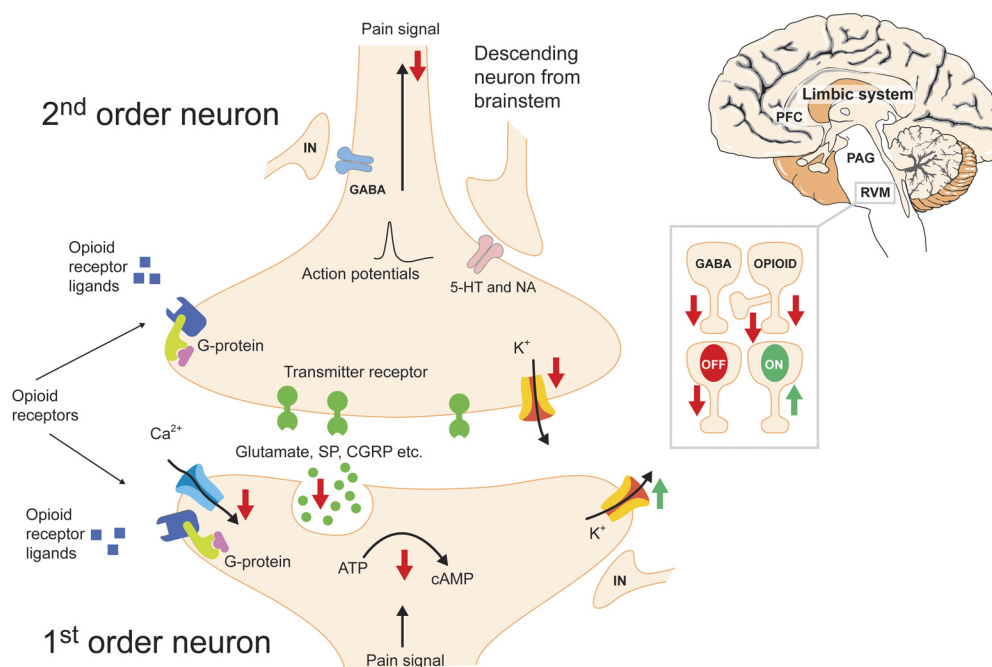

FIG. 7. Molecular mechanisms for opioid actions in the spinal cord. Red arrows represent decrease, green arrows represent increase. Left, the presynaptic action of opioid receptor activation involves inhibition of calcium influx by enhancing outward movement of potassium or by inhibiting adenylate cyclase (the enzyme that converts ATP to cAMP). The release of neurotransmitters such as SP and CGRP is inhibited. The majority of opioid receptors are located presynaptically (70%). Postsynaptic action of opioid receptor activation involves inhibition of potassium ion efflux, which decreases neuron excitability. Right, the general organization of the supraspinal opioid control mechanisms. Opioids excite neurons in brain areas mainly in the limbic system, such as prefrontal cortex (PFC), hypothalamus, amygdala, and cingulate gyrus and thereby indirectly excite neurons in periaqueductal gray (PAG). Opioids also directly excite neurons in PAG, which project to the RVM. Opioids affect ON and OFF cells in RVM by inhibiting opioid receptor-bearing ON cells. They also inhibit GABAergic inputs to OFF cells, which are then disinhibited, again leading to inhibition of nociceptive transmission. RVM neurons project to substantia gelatinosa of the dorsal horn and exert inhibitory or excitatory influence on transmission via interneurons (IN) (left). Because GABA is a major inhibitory neurotransmitter and will inhibit the facilitatory pathways, GABAergic neurons also play a role in descending control to spinal cord level.

at spinal level (Pertovaara, 2006). Among other binding sites, α_2 -adrenoceptors on secondary neurons in the dorsal horn play a role, and these can be targeted pharmacologically (Pertovaara, 2006; Heinricher et al., 2009).

Cannabinoid receptors and their endogenous ligands are also present at supraspinal, spinal, and peripheral levels. Cannabinoids suppress nociceptive processing through activation of cannabinoid CB1 and CB2 receptor subtype G protein-coupled receptors. Activation of CB1 receptors modulates neuronal calcium and potassium conductance, causing less neurotransmitter release and neuronal excitability. CB2 receptors are primarily localized to cells of the immune system (Guindon and Hohmann, 2009).

III. Animal versus Human Pain Models

It is increasingly being recognized that only a few new analgesics have entered the general market to be of use in pain patients (Berge, 2011). Of these, only one new target has been discovered: the gabapentinoids (Chizh et al., 2009). There could be several reasons for this lack of success in drug development, but one of the explanations could be that the preclinical pain models do not properly predict the clinical efficacy in humans (Kola and Landis, 2004; Chizh et al., 2009).

Species differences can cause diverse responses to pharmacological treatment. Large interspecies differences exist even in related species of rodents such as rats and mice. This can be due to receptor dissimilarity, leading to different activity and/or pain attenuation in some species compared with others. Examples of this include neurokinin 1 (NK1) antagonists that showed prominent effects in a range of animal pain models but failed to attenuate pain in humans. This was highly unlikely to have been caused by differences in pharmacokinetics, because the human studies were well designed, dose-finding relying on positron emission tomography (PET) ligand studies (Hill, 2000; Bergström et al., 2004; Chizh et al., 2007). Therefore, the failure of this drug class was probably caused by species differences in the role of NK1 receptors in pain.

Species differences in pharmacokinetics can also lead to wrong doses applied in early clinical development. When incorrect doses are applied in clinical trials, this can produce either an unacceptable level of adverse events or a lack of efficacy, resulting in termination of development of the current drug (Lowe et al., 2007). Examples of important species differences in pharmacokinetics are those related to protein binding, metabolism, and the presence of active transporters at mem-

branes (Lin et al., 1994; Lin, 1995; Lin and Yamazaki, 2003). Examples of study failures due to pharmacokinetics, however, are rarely found in literature because such studies are usually not published.

Besides the presence of species differences, preclinical models look predominantly at evoked pain, whereas the clinical trial endpoint often include the results of a questionnaire (e.g., the mean numeric rating scale considering pain over the last 24 h). These types of endpoints reflect a sum of different components, whereas the predominant determinant should be spontaneous and ongoing pain, but with influence from confounders related to side effects, psychological responses, social situation etc. (Shankland, 2011). However, there has been an increasing focus on developing animal models that investigate pain-depressed behavior, which may reflect clinical pain to a larger extent (Negus et al., 2006).

The most potent analgesics have their actions in the central nervous system. Here, a key player such as the opioid system is different between species; considering the major morphological and functional differences between brains of rodents and humans, it is to be expected that differences are quite distinct (Yoburn et al., 1991). Animal studies are based mainly on motor reflexes or behavioral responses, and data from such studies can be interpolated only partly to pain, which is a net result of complex sensory, affective, and cognitive processing. Hence, in animals, there is an under-representation of key brain areas dealing with the affective component of pain (Price, 2000, 2002). Finally, because many of these models are also optimized for success, the construct validity is often limited (Chizh et al., 2009); in fact, only one analgesic (ziconotide) has ever gone from bench to bedside on the basis of animal models alone (Dolgin, 2010).

IV. Clinical Studies versus Experimental Human Pain Models

Pain in patients is accompanied by several factors, such as fear, emotion, anxiety, cognitive and autonomic responses, general malaise, and so forth, influencing the overall sensory experience (Melzack, 1975). Pain is a subjective experience and because of the influence of individualized factors, pain intensity does not correlate well with the severity of the pathological condition (Mao, 2009). Moreover, a painful experience often differs between sexes and cultural backgrounds (Price, 2000; Coghill et al., 2003; Greenspan et al., 2007; Campbell et al., 2008). Hence, improvement in depression, for example, during treatment with a new drug can result in lower pain ratings. It can therefore be difficult to evaluate analgesic effects and specific mechanisms in patients with pain, and even studies with well known analgesics such as NSAIDs are frequently inconclusive (Bjrdal et al., 2004).

Experimental pain in healthy volunteers makes it possible to overcome some of this bias and therefore seems to be better suited not only to investigate the analgesic effects but also to study pain mechanisms. The basic concept in these models is to control the stimulus and assessment parameters (Fig. 8) (Stahl et al., 2006a; Arendt-Nielsen et al., 2007a). It is essential that intensity, duration, frequency, and localization of the experimental stimuli be controlled. These parameters determine the quantity of nociceptive information from the periphery to the central nervous system (Stahl et al., 2009a). To mimic the clinical situation, where many mechanisms come into play, different modalities (electrical, thermal, mechanical, or chemical) are typically used (Stahl et al., 2009a). When a given experimental stimulus results in a stable and reproducible response, it becomes a sensitive method for detecting analgesic actions (Fig. 8). The evoked pain sensation is often assessed quantitatively by use of a visual analog scale (VAS) or qualitatively by use of questionnaires. Nevertheless, the visual analog scale is typically used only for the sensory dimension of the pain sensation and is therefore not ideally suited for detailed investigation of pain pathways or elucidation of the underlying mechanisms. A combination of subjective measurements with objective assessments (for example, cerebral evoked potentials, nociceptive reflexes, or imaging) to assess the multiple dimensions of pain is therefore a better solution. In evaluation of analgesics, most studies have applied models in the skin, but from a clinical perspective, deep pain and models in which hyperalgesia and allodynia is evoked are more relevant. Subsequently, reliable and valid pain models from muscle, bone, and viscera have been developed together with chemical models evoking hyperalgesia (Drewes et al., 2003; Arendt-Nielsen et al., 2007a; Olesen et al., 2009b; Stahl et al., 2009a; Andresen et al., 2010). This mimics the clinical situation to a better extent, and in these models the effects of analgesics have been consistently reported (Koppert et al., 2005; Olesen et al., 2010a).

Human pain models can, at least in part, close the gap between preclinical measures and clinical trials (Olesen et al., 2009a). As such, they can give the researchers important confidence in continuing the development of a drug even in the case of inconclusive results in phase II trials. To recognize the time-dependent contribution of the concentration of a drug, pharmacokinetic-pharmacodynamic modeling is suitable. This type of analysis, normally used only in experimental pain studies when potential analgesics are tested, enables detailed study of the concentration-effect relationship of analgesics and their metabolites. This reveals any delay between measured plasma concentration and effect. In addition, both inter- and intraindividual variability can be elucidated, and multiple factors such as weight, height, and so forth can be accounted for. Therefore, the involvement of pharmacoki-

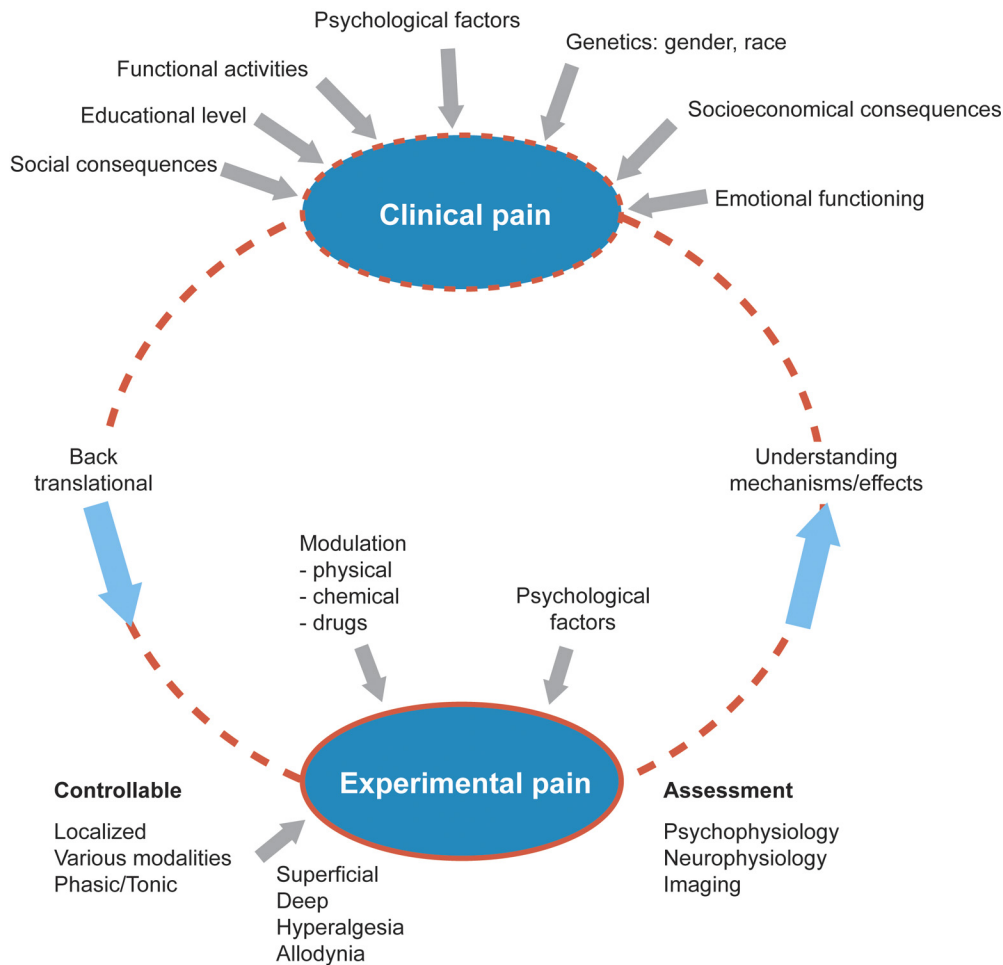

FIG. 8. Clinical versus experimental pain. Schematic overview of factors influencing a patient's perception of pain in the clinic (top) and illustration of concepts in experimental pain (bottom). In human research comprehensive trials in patients are often used to evaluate pain mechanisms and effect of analgesics. However, clinical pain is accompanied by several factors, such as anxiety, disability, isolation, depression, etc. This will influence the overall sensory experience. Experimental pain in healthy volunteers makes it possible to overcome some of the bias and therefore is better suited to investigate not only the analgesic effects but also pain mechanisms. It is essential that intensity, duration, frequency, and localization of the experimental stimuli are controlled. To mimic the clinical situation, where many mechanisms come into play, various modalities (electrical, thermal, mechanical, or chemical) as well as a combination of phasic and tonic models and models inducing hyperalgesia are typically used. Phasic models are short lasting and have limitations compared with the complex clinical conditions, whereas models inducing tonic stimuli and hyperalgesia can act as proxies for the clinical manifestations. When a given experimental stimulus results in a stable and reproducible assessment, it is possible to modulate the stimulus by, for example, chemicals or analgesics. The evoked pain sensation can be assessed in a subjective manner by use of VAS or questionnaires (psychophysiology), but to go beyond this one-dimensional way of assessing pain, subjective measurements can be combined with objective methods (neurophysiology and imaging) such as EEG, MEG, fMRI, or PET/SPECT. Findings from experimental pain can be used to facilitate understanding of disease and pharmacological mechanisms, and clinical pain can also explain results from experimental pain studies.

netic and dynamic modeling can give important knowledge on how to perform a secure dose-finding for the first trials in patients, thereby optimizing the chances for success (Lowe et al., 2007). It should be stressed, however, that comprehensive experimental models are more difficult to apply and are available only in the most advanced laboratories, which limits their general use.

V. Experimental Human Pain Models

Several models of human experimental pain stimulation exist. Important experiments related to pathophysiological changes in the pain system are induction of hyperalgesia and allodynia (Dirks et al., 2002; Hughes et al., 2002; Koppert et al., 2003b). Such procedures may be helpful in the evaluation of various drug effects on

peripheral and central mechanisms. In this section, human pain models are described and discussed for different tissues (skin, muscle, and viscera) and different modalities. Both acute models and models of hyperalgesia are described.

A. Skin

Experimental pain models in the skin are extensively used, probably because of the easy access to the skin. Mechanical, thermal, electrical, and chemical methods make up evaluated techniques.

1. Mechanical Stimulation. Different methods exist for mechanical skin stimulation. The advantages for mechanical stimulation of the skin are that an exact and reproducible pressure can be applied to the skin and

that the response can be assessed quantitatively. Limitations will be described after description of each specific method.

a. Touch. Light mechanical stimulation can be applied by using a von Frey hair, a cotton swab, or a brushstroke. Von Frey hairs are calibrated filaments that bend when a certain pressure is reached and therefore can be used for mechanical stimulation. $A\beta$ fibers probably mediate touch sensation. Using thicker and stiffer filaments will produce pinprick stimulation, which activates predominantly $A\delta$ fibers (see section V.A.1.b) (Curatolo et al., 2000a; Le Bars et al., 2001).

This method has limitations, because applying light mechanical stimulation will not induce pain. Therefore, its main use is as a tool to explore allodynia or pinprick hyperalgesia (Curatolo et al., 2000a). Furthermore, von Frey hair stimulation is nonspecific and activates nociceptors as well as low threshold mechanoreceptors (Le Bars et al., 2001).

b. Pinprick. Pinprick stimulation can be performed by stimulating the skin with a needle or thick von Frey filaments, predominantly activating $A\delta$ fibers, reported as pricking (Curatolo et al., 2000a; Le Bars et al., 2001).

A limitation is that conventional techniques do not allow noxious stimuli to be delivered rapidly and briefly enough to produce synchronous excitation of nerve fibers. Moreover, if mechanical stimuli were truly nociceptive, they would probably produce lesions (Staahl and Drewes, 2004).

c. Pressure. Pain can be induced in the skin by pressure algometers (Curatolo et al., 2000a). For example, skin or an ear lobe can be pinched between the algometer probe and a pinch handle. Pain induced by pressure stimulation is mediated by both $A\delta$ and C fibers (Curatolo et al., 2000a).

Limitations exist with this method. For example, when measuring any variable, it is important that the examiner induces pain in a consistent way. Handheld devices are often used and they have a "maximum hold" function that displays the maximum pressure obtained in any application (Kinser et al., 2009). Variation in rate of pressure increase has been suggested to be the factor most affecting reliability. To minimize this effect, most pressure algometers use a fixed rate, and it has been proposed that testing should be performed by one examiner, which enhances reliability (Nussbaum and Downes, 1998). Mechanoreceptors are excited in addition to nociceptors, limiting the use in psychophysiology. Moreover, it is not possible to provide a fast and precisely controlled stimulus onset required for studies of, for example, evoked brain potentials (Handwerker and Kobal, 1993).

2. Electrical Stimulation. Various stimulator devices connected to electrodes applied to the skin surface are developed to evoke electrical stimulation of the skin (Handwerker and Kobal, 1993).

Advantages are that the temporal aspects of electrical stimuli are easy to control, and the method is widely used for inducing pain in the skin (Handwerker and Kobal, 1993). Various stimulation paradigms with diverse waveforms, frequencies, and durations are used to selectively activate different afferents and nervous structures and thereby evoke various pain sensations. The method is suitable for neurophysiological assessments of the pain. In addition, summated stimuli can activate central mechanisms (Koppert et al., 2001). This is described further in section VI.

However, limitations exist as well. For example, electrical stimulation of the skin bypasses the sensory nerve endings, resulting in loss of information on receptor functioning in the periphery. Moreover, electrical stimuli will excite the afferent pathways in an unnatural synchronized manner and excite the full spectrum of peripheral nerve fibers unless parts of the fibers are blocked (Handwerker and Kobal, 1993). Moreover, stimulation of different body sites will show various electrode impedance, and this may affect the results (Le Bars et al., 2001).

3. Thermal Stimulation.

a. Cold. Cold sensation and pain in humans are mediated by $A\delta$ and C fibers. Cold stimulation can be performed by ice, a cold gel bag, a wet alcohol sponge, or a cooling thermode to the skin. It is assumed that $A\delta$ fibers mediate cold sensations, and C fibers most likely mediate cold pain in humans (Fowler et al., 1988). Cold stimuli have been used in the form of the cold pressor test, which is noxious cooling of the forearm or other extremities by immersion in ice water. In this review, the cold pressor test is described in section VI.A.

The advantage is that warming and cooling are believed to be conveyed by different peripheral nerve fibers: sensations of warming in unmyelinated peripheral nerve fibers and those of cooling in small myelinated fibers. Therefore, the capability of measuring the threshold for warming and cooling separately is very valuable, and estimation of thresholds can be used to examine the functional integrity of these fibers, which are inaccessible to clinical electrophysiological investigations (Fowler et al., 1988).

The limitation is that a large variability in the measurement of pain threshold, withdrawal threshold, and subjective pain, especially in some subjects, has been reported for the cold pressure test (Blasco and Bayés, 1988). Furthermore, there is no standardization with respect to the duration of extremity cooling and how the response is rated.

b. Contact heat. Heat pain can be evoked by a heating thermode. Rapid skin-heating pain activates first $A\delta$ fibers, where the evoked sensation corresponds to the "first pain" felt within less than 0.5 s after the heat stimulus. The first pain is followed by a C-fiber-mediated second pain, which is of longer duration and less well localized. A or C fibers are activated depending on

whether the skin is heated at a rapid or slow rate. Slow heating (less than 1°C/s) gives a preferential activation of C fibers (Handwerker and Kobal, 1993).

Advantages include that the contact heat evoked potential stimulator represents a novel technique that uses rapidly delivered heat pulses with adjustable peak temperatures to stimulate the differential warm/heat thresholds of receptors expressed by A δ and C fibers resulting in evoked brain potentials (Le Pera et al., 2002; Roberts et al., 2008).

However, limitations include the fact that radiation devices and thermodes for heat stimulation exist. Therefore, even when the skin surface temperature is controlled, stimuli applied with different methods are not necessarily comparable, because the intracutaneous temperature profiles may be different depending on wavelength or type of contact (Handwerker and Kobal, 1993). This makes comparisons difficult between, for example, different drug studies. The speed of conventional cutaneous heating is usually slow and does not allow for an appropriate study of neural phenomena (Le Bars et al., 2001).

c. Laser. Light amplification by stimulated emission of radiation (i.e., LASER) is a special light source possessing the ability to evoke heat pain and are applied to the skin by noncontact radiation pulses emitted by CO₂ lasers, thulium lasers, or diode lasers (Plaghki and Mouraux, 2003; Frahm et al., 2010). A δ fibers (mean conduction velocity, 14 m/s) and C fibers (0.8 m/s) are activated simultaneously, and the perceived pain is described as “pricking” (Bromm and Treede, 1991). It has been demonstrated that short high-intensity diode laser pulses may selectively produce A δ -mediated pain in humans and that longer duration, lower intensity pulses may selectively produce C-mediated pain in humans (Tzabazis et al., 2011). This knowledge may be useful in evaluation of differential pharmacological effects and physiologic mechanisms of these two distinct pain types (Tzabazis et al., 2011).

An advantage is that lasers deliver large amounts of energy to the skin in a highly reproducible manner and are therefore efficient and temporally well controlled heat stimulators that are useful for quantitative sensory testing and recording of time-locked evoked brain potentials (Plaghki and Mouraux, 2003; Frahm et al., 2010). Another advantage is that the stimulus can be applied without direct contact to the skin, providing a purely thermal stimulation (Staahl and Drewes, 2004; Tzabazis et al., 2011). In addition, lasers allow brief pulses (microseconds to milliseconds) with very fast rise time.

A limitation is that the response will vary according to transmission and absorption of the epidermis, resulting in high interindividual variability (Bromm and Treede, 1991). Furthermore, lasers are expensive and cumbersome to use.

4. Models Evoking Hyperalgesia. Administration of exogenous chemicals can activate and sensitize afferent

nociceptors, leading to pain, hyperalgesia, and allodynia. Hyperalgesia is characterized by lowered pain thresholds and increased pain in response to normally painful stimuli and can occur within the injured tissue (primary hyperalgesia) but also in undamaged tissue outside the area of injury (secondary hyperalgesia) (LaMotte et al., 1991). Lewis (1936) was the first to publish an experimental study of the process by which a large area of undamaged skin surrounding a local cutaneous injury became hyperalgesic in response to mechanical stimuli. In this study, a normally innocuous light stroking evoked soreness or tenderness (“allodynia”) (Lewis, 1936).

Primary hyperalgesia is a peripheral mechanism that occurs at the site of injury, whereas secondary hyperalgesia is at least partially evoked by central mechanisms (Treede et al., 1992). However, it should be noted that the process of central nervous system sensitization is a consequence of input from primary afferent nociceptors that innervate an area of damage or inflammation (Willis, 2001). Models inducing hyperalgesia and/or allodynia may lead to visual flare, which is a diffuse erythema extending beyond the local reaction to a trauma. The flare is a neurogenic inflammatory response evoking vasodilation likely to be mediated by CGRP release from A δ and C fiber nociceptors (Pedersen, 2000).

Various models have been used to induce cutaneous hyperalgesia and allodynia (e.g., intradermal/topical capsaicin, intradermal nerve growth factor (NGF) and glutamate, burn injury, freeze lesion, laser, electrical, mustard oil, topical menthol, topical sodium lauryl sulfate, repetitive pinching, and intradermal electrical stimulation (see below for details). General advantages and limitations are described in the end of this section.

a. Capsaicin. Capsaicin is one of the most widely used models for studying human pain. This model induces hyperalgesia by either intradermal injection or application of capsaicin to the skin. Capsaicin is the pungent agent of chili peppers, producing pain and sensitization via central and peripheral mechanisms. Intradermal injection of capsaicin induces spontaneous pain via activation of C mechano-heat fibers through binding to TRP vanilloid type 1 (TRPV1) receptors. Moreover, this model evokes pinprick hyperalgesia mediated by A δ and C afferent fibers and mechanical allodynia mediated primarily by A β fibers (Scanlon et al., 2006). Mechano-insensitive C nociceptors (silent nociceptors) have shown to play a pivotal role in capsaicin-induced hyperalgesia (Weidner et al., 1999).

The topical heat/capsaicin model has been developed to achieve a noninvasive paradigm that generates stable, long-lasting, and reproducible primary and secondary hyperalgesia. The model is best used in studies of compounds with a peak analgesic effect time of 2 to 3 h because of the duration of the cutaneous sensitization (Dirks et al., 2003; Andresen et al., 2010; Modir and Wallace, 2010). Andresen et al. (2010) further demon-

strated that red-haired women were less sensitized to capsaicin-induced hyperalgesia compared with blond/dark haired women, which could be important in future studies investigating antihyperalgesic drugs as well as treatment of pain.

b. Nerve growth factor. NGF is required during development for the growth and survival of neurons. It binds to the high-affinity tyrosine kinase receptor *trkA*, expressed on peripheral and central neurons, to promote the trophic actions (Nicol and Vasko, 2007; Rukwied et al., 2010b). Furthermore, NGF can induce a *trkA*- and phosphoinositide 3-kinase-mediated translocation of TRPV1 to the cell membrane. In addition to these local mechanisms, NGF/*trkA* can be internalized and transported to the dorsal root ganglia to induce an up-regulation of sensory proteins such as TRPV1 (Rukwied et al., 2010a). In adults, the primary function of NGF is to mediate the inflammatory and immune response after tissue injury, initiating and maintaining hypersensitivity (Nicol and Vasko, 2007). Hypersensitivity has been demonstrated in a few human experimental studies, where intradermal/subcutaneous injection of NGF evoked long-lasting mechanical sensitization and profound hyperalgesia to thermal stimuli. The observed sensitivity varied in a dose-dependent manner (Petty et al., 1994; Dyck et al., 1997; Rukwied et al., 2010a). A large number of inflammatory mediators act to increase NGF production, and increased levels of NGF have been reported in human painful disorders including arthritis (Kidd and Urban, 2001). Injection of NGF therefore mimics processes found in the clinical situation.

c. Glutamate. Several studies have shown that the glutamate level in the periphery is increased in cutaneous or deep tissues in response to nerve injury, electrical nerve stimulation, and inflammation in both animals and humans (Lawand et al., 1997; Kinkelin et al., 2000; McNearney et al., 2000; deGroot et al., 2000; Rosendal et al., 2004). Glutamate plays a role in pain modulation and sensitization via activation of peripheral glutamate receptors. The activation of peripheral glutamate receptors and related Ca^{2+} influx may enhance nociception via Ca^{2+} -dependent phosphorylation of the glutamate receptors and/or further release of glutamate from the same neuronal terminal or adjacent surrounding peripheral terminals to amplify the release of glutamate into peripheral tissues (Lam et al., 2005). Moreover, glutamate receptors are also increased in cutaneous tissue during inflammation (Carlton and Coggeshall, 1999). Despite this knowledge, only one study has investigated the effect of injection of glutamate into human skin. Gazerani et al. (2006) demonstrated that subcutaneous injection of glutamate evokes pain, vasomotor responses, and pin-prick hyperalgesia in healthy volunteers. This study could also show sex-related differences in the hyperalgesic area, where women developed larger areas than men (Gazerani et al., 2006).

d. Burn injury. Burn injuries have the potential for releasing a large number of inflammatory and chemical mediators that produce sensitization and excitation of nociceptors, and the intense nociceptive input produces sensitization of central neurons in nociceptive pathways (Pedersen, 2000).

UV irradiation, especially UVB light (280–315 nm) produces a well defined erythema (“sunburn”) evoking an inflammatory response as well as allodynia and hyperalgesia. The sunburn reaches maximum after approximately 24 h, with concomitant reductions in thermal and mechanical pain thresholds in the irradiated area. The erythema is accompanied by an increased sensitivity to mechanical stimulation (secondary hyperalgesia) in the surrounding area. This indicates that central sensitization contributes to UV-induced sensory changes (Bishop et al., 2009). Bishop et al. (2009) demonstrated that magnitude and duration of thermal and mechanical sensitivity is UVB dose-dependent.

Heat stimulation has also been used to induce burns because it is easy to control and most nociceptors respond to heat (Pedersen and Kehlet, 1998). The degree of thermal burns is closely related to the surface temperature and exposure time. Various heat sources (e.g., contact thermode, lasers, and heat lamps) have been used to induce burns. One important difference between the heat sources is that the thermode coactivates slowly adapting mechanoreceptors ($A\beta$ fibers) in contrast to radiant heat stimuli, activating only $A\delta$ and C fibers (Pedersen, 2000). Heat burn has shown to induce reproducible acute inflammatory responses with differences between right and left arm regarding sensitivity (Pedersen and Kehlet, 1998). Thermal burns cause spontaneous pain during induction and lead to flare around the affected area (Norbury et al., 2007), which is not the case with UVB-induced burns (Bishop et al., 2009). The heat model has also shown to evoke habituation over time (in this context referred to as reduced responsiveness to painful stimuli during repeated stimulation). Habituation is not restricted to burn models, however, but is commonly observed in experimental pain models. Thus, habituation must be taken into consideration in pharmacology studies (Pedersen and Kehlet, 1998).

e. Freeze lesion. Induction of freeze lesions is mainly a model of peripheral hyperalgesia that stays stable over 72 h, providing the possibility for assessment of analgesic effect of long-lasting compounds or several doses. No spontaneous pain is experienced by use of the model, avoiding any interference with the evaluation of pain thresholds (Kilo et al., 1994).

f. Mustard oil. Mustard oil is a plant-derived irritant. The noxious effects of mustard oil are currently ascribed to specific activation of the cation channel TRP ankyrin type 1 in nociceptive neurons. It has been proposed that it also activates human recombinant TRPV1 (Everaerts et al., 2011). Topical administration leads to a burning pain in the area exposed to mustard oil as well

as secondary allodynia and hyperalgesia in the surrounding unaffected area, similar to the topical capsaicin model (Koltzenburg et al., 1992).

g. Menthol. Menthol acts as an agonist on the TRP melastatin member 8. The topical application of high-concentration (40%) menthol, is thought to activate and sensitize cold-sensitive TRP melastatin member 8- and TRPV1-expressing C-nociceptors and activates cold-specific A δ fibers (Binder et al., 2011). Moreover, it has been demonstrated that TRP ankyrin type 1 is a highly sensitive menthol receptor that very likely contributes to the diverse psychophysical sensations after topical application of menthol to the skin or mucous membranes of the oral and nasal cavities (Karashima et al., 2007). Topical application has been introduced as a surrogate model of cold hyperalgesia, which is a major clinical phenomenon in patients with peripheral or central nervous system lesions (Hattem et al., 2006). Besides cold hyperalgesia, the model elicits primary and secondary mechanical (pinprick) hyperalgesia combined with the sensation of burning (Binder et al., 2011). This model has been to be sensitive to a range of analgesics (Altis et al., 2009).

h. Acid phosphate buffer. Acid solutions are known to evoke severe pain when injected into the skin. In addition, tissue acidosis plays a role in painful inflammatory and ischemic conditions (Steen et al., 1995). Intradermal injection of acid phosphate buffer leads to graded cutaneous pain and mechanical hyperalgesia (Steen and Reeh, 1993).

i. Sodium lauryl sulfate. Sodium lauryl sulfate (SLS) is a skin irritant used in the evaluation of skin susceptibility to irritation. It induces the release of inflammatory substances [e.g., tumor necrosis factor- α , interleukin (IL)-1 α , IL-6, and IL-8] considered pivotal in peripheral pain modulation. Petersen et al. (2010) demonstrated that SLS evoked localized inflammation and primary hyperalgesia to tactile and thermal stimulation 24 h after application. SLS-induced inflammation most likely involves some degree of C fiber activation. The model could be more relevant for studies of mechanisms that underlie inflammatory and neuropathic pain conditions (Petersen et al., 2010).

j. Pinch. By use of repetitive pinch to the web between the fingers, it is possible to increase pain rating, reflecting hyperalgesia to pinching. The model depends on the ability of the interdigital webs to become more sensitive to the pressure applied by repeated pinching. It is likely that C fibers are activated, leading to increased excitability of spinal neurons. This in turn leads to reduced mechanical threshold, activating A β fibers. In addition, inflammatory mediators are released, leading to increased sensitivity (Growcott et al., 2000). However, it is not clear whether the hyperalgesia stems from mechanisms other than those evoked by inflammatory mediators, because it is well known that if a stimulus is repeated at a fast rate (interstimulus interval below 3 s),

the pain increases as a result of central amplification of the response (temporal summation) (Staaht and Drewes, 2004).

k. Electrical stimulation. The silent nociceptors are characterized by an unusually high transcutaneous electrical activation threshold, but application of high-intensity transcutaneous electrical stimuli (50 mA, 0.5 ms) induces large areas of secondary mechanical hyperalgesia and flare (Schmelz et al., 2000). The model has shown to be valid and stable over time. However, a major difference between this model and capsaicin is that electrical stimulation bypasses the nerve terminals by direct axonal activation, yielding better control of nociceptor firing frequency. The model will not detect effect of drugs that impair the response of peripheral nerve terminals. However, the model has shown to be suitable for investigating analgesic and antihyperalgesic effect of drugs (e.g., alfentanil, ketamine, and lidocaine) (Koppert et al., 2001).

Among the advantages is the fact that experimental models inducing allodynia and/or hyperalgesia have been used to show effect of analgesics (Staaht et al., 2009a,b). Such models are of interest when investigating effect and mechanisms of drugs because they can act as proxies for clinical manifestations and are therefore more clinically relevant than phasic pain models (Negus et al., 2006). Moreover, the models are suitable for studies investigating effect and mechanisms of drugs because they produce long-lasting allodynia and hyperalgesia for up to several days.

Limitations include the fact that models inducing not only allodynia and/or hyperalgesia but also inflammatory responses may activate silent C fibers. Thus the activation of A δ fibers may transform into thresholds for activation of C fibers, and as these respond to other stimulus modalities, it may confuse the evaluation of analgesics (Le Bars et al., 2001).

It is also important to keep in mind that models inducing allodynia and/or hyperalgesia are more difficult to control with respect to reproducibility compared with the phasic pain models (Staaht et al., 2009a,b). This problem can be overcome by applying larger samples when analgesic effects are tested.

B. Muscle and Bone

Human experimental muscle pain models have been divided into methods without (endogenous) and with (exogenous) external stimuli. Ischemic and exercise-induced muscle pains are typical endogenous pain models, whereas external stimulation with mechanical, electrical, and chemical modalities constitutes the exogenous models (Graven-Nielsen and Arendt-Nielsen, 2003; Graven-Nielsen, 2006). Experimental muscle pain may also be perceived in areas remote from the affected part (referred pain), and the area of referred pain has shown to correlate with the intensity of muscle pain (Mense, 1997). The pathogenesis of

bone-associated pain is still not fully understood, but it is known that the periosteum is innervated by unmyelinated nociceptive afferents (Grönblad et al., 1984). These nociceptors are sensitive to high-intensity pressure (Grönblad et al., 1984).

1. Mechanical Stimulation.

a. Muscle. Mechanical stimulation by use of pressure, for example, is a typical exogenous experimental pain model. Handheld pressure algometry is the most frequently applied technique for quantification of pain. The method is an experimental parallel to palpation in clinical practice (Graven-Nielsen and Arendt-Nielsen, 2003). The pain threshold and tolerance thresholds are easily measured. In addition, stimulus-response functions give information on muscle hyperalgesia (and analgesic profiles). The force increase rate is normally kept relatively constant, and absolute values are monitored when hand-held algometers are used. Methodological concerns such as short- and long-term reproducibility, influence of pressure rates and muscle contraction levels, and examiner expectancy have been addressed carefully (Graven-Nielsen and Arendt-Nielsen, 2003). An alternative to handheld pressure algometry is a computer-controlled algometer, allowing rate and peak pressure to be predefined and controlled automatically (Graven-Nielsen and Arendt-Nielsen, 2003). However, the computer-controlled algometer is a more complex set-up compared with the handheld algometer. Another method for evoking mechanical stimulation is the cuff algometry technique. Compared with pressure algometry, the cuff model can be used to establish stimulus-response recording of pain response to increasing pressure. This technique is fully computer-controlled, which increases the reliability and sensitivity (Polianskis et al., 2001).

Advantages include the fact that standardization of the technique of pressure algometry has been attempted, and reference values for various muscles are published (Fischer, 1998). Pressure algometry has been used in evaluating drug efficacy (Staahl et al., 2006a; Arendt-Nielsen et al., 2009) as well as to evoke temporal summation by repeated pressure. It was demonstrated, for example, that temporal summation was facilitated in patients with fibromyalgia compared with healthy volunteers, indicating involvement of central sensitization in patients with fibromyalgia (Staud et al., 2003). The cuff algometry technique is reliable and sensitive, and the model has been applied in pharmacological testing (Arendt-Nielsen et al., 2009; Olesen et al., 2010a).

However, a limitation is that the techniques for mechanical muscle stimulation are not tissue-specific because receptors in the skin are activated as well (Graven-Nielsen and Arendt-Nielsen, 2003). Findings in a recent study suggest that pressure algometry-induced muscle pain is mainly related to muscle strain and is most efficiently induced by large rounded probes (Finocchietti et al., 2011).

b. Bone. Mechanical pressure has been applied to different bone structures (e.g., mastoid processes, external malleolus, and sternum) (Vatine et al., 1993). Most studies have used the tibia. First Hamilton et al. (1967) showed that pressure with a metal probe to the surface of the tibia evoked pain. A study by Finocchietti et al. (2012) demonstrated that probe size is important to evoke bone pain with clinical characteristics.

The advantage is that the model has been used in assessment of analgesics (Andresen et al., 2010), and it has been shown that the model is reproducible with minor pain component of the overlying skin (T. Andresen, M. P. Jensen, C. Brock, A. M. Drewes, L. Arendt-Nielsen, unpublished observations).

Limitations include the fact that indentation of the skin and shape of the probe are important factors influencing mechanical pressure stimulation (Greenspan and McGillis, 1991). It is therefore important to stimulate an anatomical site (e.g., the tibia) that is easy to access and has the least influence of pain deriving from other tissues (e.g., muscle and nerves) to evoke bone-associated pain. So far, however, no study has systematically investigated the probe size that would be optimal to evoke bone-associated pain.

2. Electrical Stimulation. Muscle pain can be induced experimentally by electrical stimulation by needle electrodes with uninsulated tips inserted into muscles (e.g., the left tibialis anterior muscle) (Schulte et al., 2003).

Advantages are that intramuscular electrical stimulation results in pain that is present only during the stimulation. Repeated electrical stimulation can induce temporal summation, manifested as increase in referred pain areas or pain rating, reflecting central changes (Schulte et al., 2003). Electrical stimulation offers a unique possibility to compare muscle and skin pain with the same modality. For example, it has been shown that remifentanyl caused a higher increase in the muscular pain thresholds than in the cutaneous pain thresholds, and it was concluded that opioids inhibit muscular pain more strongly than cutaneous pain in humans (Curatolo et al., 2000b).

A limitation is that electrical stimulation first elicits non-nociceptive input to the CNS because it bypasses the receptors, resulting in a nonphysiologic stimulation. This is likely to alter the effects of the ensuing nociceptive input (Graven-Nielsen and Mense, 2001). Furthermore, concurrent activated muscle twitches may confound the sensation evoked by intramuscular electrical stimulation and lead to a change in placement of electrodes, thus reducing reproducibility (Staahl et al., 2006b).

3. Thermal Stimulation. Injection of 48°C isotonic saline has been used in a few cases for muscle stimulation. The injection elicits not a sensation of heat but mild pain, and it has therefore been suggested that thermally induced muscle pain is nociceptive-specific (Graven-

Nielsen et al., 2002). This methodology has not yet been applied in trials with analgesics.

Advantages include the fact that a thermal stimulus is a more specific stimulus compared with, for example, hypertonic saline (see section IV.B.4.c), because hypertonic saline activates a broader population of nociceptors.

One limitation is that in contrast to thermal skin stimulation, where subjects can differentiate between cold and warm stimuli, this is not possible for the thermal muscle stimulation (Graven-Nielsen and Mense, 2001). Knowledge on reproducibility would be useful for the use of this model in analgesic testing.

4. Models Evoking Hyperalgesia.

a. Ischemic Stimulation. The tourniquet model (see section V.B.1.a) can be used to induce ischemic muscle pain, for example in combination with voluntary muscle contractions or exsanguinations of the leg by gravity. Level of force and duration are important factors for the resulting pain. The mechanisms behind it are not fully understood, but accumulation of various substances (e.g., potassium, adenosine, lactate) has been suggested to play a major role in the excitement of muscle nociceptors (Graven-Nielsen and Arendt-Nielsen, 2003). The tourniquet can be left inflated as long as the subject tolerates the pain, for a maximum of 2 h.

Advantages include the fact that the model is applicable in experimental studies requiring a general tonic pain stimulus (Graven-Nielsen, 2001). Because the method is found reliable, it can be used in trials with analgesics (Graven-Nielsen and Arendt-Nielsen, 2003).

It is a very efficient model to induce pain in the muscles, but a limitation is that pain is not evoked solely from the muscle tissue and skin; periosteum and other tissues will contribute to the overall pain perception.

b. Exercise-induced muscle pain.

i. Concentric muscle work. Concentric muscle work is an endogenous method of exercise-induced muscle pain that is normally short-lasting and a result of impaired blood flow during work (Graven-Nielsen, 2006). It may therefore resemble ischemic muscle pain. However, ultrastructural damage resulting in the release of algogenic substances may lead to delayed onset of muscle soreness. This may produce an inflammatory reaction resulting in hyperalgesia (Graven-Nielsen, 2006).

An advantage is that the endogenous methods such as muscular contraction probably mimic clinical pain to a high degree. It has been demonstrated that the time to reach maximum intensity is inversely proportional to the amount of the load (Vecchiet et al., 1983).

The model has the disadvantage of involving several or all muscle groups within the region investigated and therefore may be difficult to control, producing less reproducible measures.

ii. Delayed onset muscle soreness. Delayed onset muscle soreness (DOMS) is a transient effect of unaccustomed eccentric exercise that in the healthy popula-

tion typically peaks 24 to 48 h after exercise. DOMS is most apparent with movement or application of mechanical pressure over the affected muscles and may be considered a form of allodynia or mechanical hyperalgesia (Ayles et al., 2011). Intensity and duration of exercise are important factors influencing DOMS onset. Several hypotheses have been suggested for the mechanisms of DOMS (e.g., lactic acid, muscle spasm, connective tissue damage, muscle damage, inflammation, and enzyme efflux). However, integration of two or more of these mechanisms is likely to explain the muscle soreness (Cheung et al., 2003). A study by Nie et al. (2006) also demonstrated that pressure-evoked DOMS might facilitate temporal summation of pain, suggesting that central sensitization is an important component in DOMS. Moreover, pressure pain thresholds decreased 24 h after exercise, indicating mechanical hyperalgesia of the involved muscle. The hyperalgesia could be a result of released endogenous substances such as bradykinin and prostaglandin E₂, substances known to stimulate and/or sensitize muscle nociceptors (Nie et al., 2006).

An advantage is that the model could be of interest in trials investigating analgesic effects, because the model mimics the clinical situation to a high degree, central sensitization playing an important role in patients suffering from chronic pain. Another feature of delayed muscle soreness is that there is no pain at rest; pain is evoked by muscle function and during palpation, which is in contrast to spontaneous pain induced by exogenous experimental techniques (Graven-Nielsen and Arendt-Nielsen, 2003).

One limitation is that in general, it has been suggested that the development of muscular hyperalgesia is dependent on the size of the muscle and possibly the level of afferent barrage. This was supported by Svensson et al. (1995), demonstrating that pressure pain threshold was higher for a large muscle compared with a smaller muscle. This should be considered when results are compared between studies.

c. Chemically induced muscle hyperalgesia. Several models exist for intramuscular infusion of endogenous substances to evoke pain and tenderness (Mørk et al., 2003). A number of substances and concentrations as well as their combinations have been explored (Mørk et al., 2003). Examples given are NGF, hypertonic saline, capsaicin, glutamate, bradykinin, serotonin, histamine, prostaglandin, ATP, and phosphate buffer. In this review, only the most widely used methods are described, and the reader is referred to other papers for more specific information (Babenko et al., 1999a,b; Graven-Nielsen and Arendt-Nielsen, 2003; Graven-Nielsen et al., 2003; Mørk et al., 2003; Frey Law et al., 2008). Each substance is described individually and general advantages and limitations are given at the end of this section.

i. Hypertonic saline. Intramuscular injection of hypertonic saline (0.5 ml, 5.8%) has been used extensively (Graven-Nielsen and Arendt-Nielsen, 2003) because it

has been demonstrated that injection of hypertonic saline into tendon sites provokes localized mechanical hyperalgesia (Slater et al., 2011). It has been found that the proximal tendon-bone junction and tendon sites are more sensitive and susceptible to sensitization by hypertonic saline than muscle bellies (Gibson et al., 2006).

ii. Nerve growth factor. Intramuscular injection of NGF has been shown to induce long-term sensitization and time-dependent hyperalgesia, indicating potential involvement of both central and peripheral pain mechanisms (Andersen et al., 2008). NGF has been used in both basic pain studies and in studies investigating analgesic effects, and has been injected into, for example, the extensor digitor longus muscle (Andresen et al., 2010), the middle of the muscle belly of the tibialis anterior (Andersen et al., 2008) or the masseter muscle (Svensson et al., 2008). The model has been shown to induce long-lasting, pressure-evoked soreness of the muscle and time-dependent pressure hyperalgesia, most likely involving peripheral and central mechanisms, and is applicable in testing of analgesics (Andresen et al., 2010). The effect of NGF on muscle contraction can also be tested, and this has been done by use of a custom-made shoe with 3 kg attached distally, leading to muscle hyperalgesia to distant areas, indicating involvement of central mechanisms (Andersen et al., 2008). NGF induced hyperalgesia has been found to be dose-dependent in both animals and humans (Petty et al., 1994; Hathway and Fitzgerald, 2006).

iii. Capsaicin and glutamate. Decreased pressure pain threshold after intramuscular injections of capsaicin has been shown (Witting et al., 2000). Intramuscular injections of glutamate produce pain and hyperalgesia to pressure stimuli in humans (Cairns et al., 2001; Svensson et al., 2003b). It has been demonstrated that intramuscular administrations of glutamate and capsaicin interact and influence pain and sensitization of muscle nociceptors: glutamate causes a sensitization to subsequent administration of capsaicin, whereas capsaicin is associated with desensitization to subsequent injection of glutamate (Arendt-Nielsen et al., 2008).

Advantages with models of chemically induced muscle hyperalgesia are that the induced pain caused by intramuscular infusion of endogenous substances is comparable with acute clinical muscle pain with localized and referred pain (Graven-Nielsen and Arendt-Nielsen, 2003). The method is reliable for studying referred pain from musculoskeletal structures because of longer lasting pain (Graven-Nielsen and Arendt-Nielsen, 2003). A major advantage of NGF injection is that it is not painful but causes a hyperalgesic area that increases over time. It has been demonstrated that injection of NGF into the human masseter muscle causes local signs of mechanical allodynia and hyperalgesia that persist for at least 7 days (Svensson et al., 2003a). Because of the long-lasting hyperalgesia it has been proposed that the NGF pain model mimics clinical pain conditions better than other

models of muscle pain and hyperalgesia, such as intramuscular injection of hypertonic saline or electrical stimulation (Gerber et al., 2011).

On the other hand, a limitation is that intramuscular infusion of endogenous substances can be difficult to control, and the duration of hyperalgesia is dependent on dose and the size of the muscle (Andersen et al., 2008).

C. Viscera

The effect of analgesics on visceral pain is difficult to evaluate clinically because of the deep and diffuse nature of the pain and the accompanying autonomic symptoms (Drewes et al., 2003). Because of the localization of the organs, experimental pain studies in the viscera are difficult to perform. The risk of perforation and the increased autonomic responses to visceral stimuli also limit the possibilities (Ness and Gebhart, 1990). Despite these challenges, experimental pain has been evoked in different parts of the gastrointestinal (GI) tract (Ness and Gebhart, 1990; Drewes et al., 2003), the urinary tract (Maggi, 1993), and the uterine cervix (Drewes et al., 2003). Models have been developed in which the investigator can stimulate with different modalities and hence activate diverse groups of afferents. Sensitization of the nervous system is also possible by, for example, perfusion of the gut with chemical substances. Thus, peripheral and central mechanisms relating to the clinical situation involving chronic pain syndromes can be evoked and the effect on pharmacological modulation can be evaluated. Most models have been used in the GI tract, and only these will be reviewed here.

1. Mechanical Stimulation. The mechanical properties of the GI tract are important for its function as a digestive organ, and the gut contains mechanoreceptors at various locations in the wall, mainly in the muscle layers (Sengupta and Gebhart, 1994). Mechanical stimulation in hollow organs is done via distension. To distend organs such as the esophagus, the small intestines, or the rectum a balloon is used. Widely used methods are computerized systems such as the "Barostat," where the pressure and volume can be controlled (van der Schaar et al., 1999). Several protocols and stimulation paradigms are recommended for the Barostat, such as, for example "phasic and tonic distensions." The stimulation paradigms have been thoroughly discussed; for review, see van der Schaar et al. (1999).

The major advantage of the barostat system (and similar pressure-volume-based methods) is the relatively low costs and reliability making it useful for routine purposes. Most studies have used volume as a surrogate measure of the activation of mechanoreceptors and this produces acceptable reliability (Stahl et al., 2006a,b; Arendt-Nielsen et al., 2009; Olesen et al., 2010a).

There are major limitations with these systems relating to, for example, elongation of the balloon during distension. Any bag will tend to elongate in the luminal

direction, where the resistance is less, rather than distend the gut wall. Hence, recordings of volume (and tension) may suffer from errors due to elongation and deformation of the bag and do not reliably reflect the activation of mechanoreceptors (Gregersen and Christensen, 2000; Gregersen et al., 2007). Because many organs, such as the rectum and stomach, are not spherical, this may cause further bias in the assessment of the degree of distension. These problems may be overcome by calculation of the balloon radius and strain in the tissue using impedance planimetry or ultrasound (Drewes et al., 2003). In accordance with recent studies, strain of the gut is probably the most consistently mechanical parameter relating to the activation of mechanoreceptors and possibly the subjective sensory response (Drewes et al., 2003). However, the technical complexity of such systems has limited their use in drug studies.

2. Electrical Stimulation. Depolarization of the nerve afferents by electrical current has been widely used as an experimental stimulus of the human gut—for review, see Ness and Gebhart (1990).

Advantages are that the electrical stimuli have proved to be safe in all parts of the GI tract. Electrical stimuli are easily controlled over time, and central pain mechanisms can be studied by using, for example, repeated electrical stimuli (Drewes et al., 2003; Brock et al., 2009b).

The major limitation and challenge with electrical stimulation is the varying electrode contact with the mucosa, giving inconsistent results. Integrating the electrodes on the biopsy forceps for the endoscopes provides a solution to this problem, allowing stimulation of well-defined areas throughout the GI tract. However, this is for the subjects more unpleasant than application of a soft probe, and the increased unpleasantness can possibly interfere with the pain experience.

3. Thermal Stimulation. Luminal heat stimulation activates the afferents in the mucosa selectively through TRPV1 receptors. This is opposed to mechanical and electrical stimuli, activating afferents in both superficial and deeper layers in the viscera (Sengupta and Gebhart, 1994). Although thermal stimuli of the gut have been used to some extent in animal studies (Ness and Gebhart, 1990), only few human studies have used temperature stimuli in the human GI tract (Staahl et al., 2006; Arendt-Nielsen et al., 2009; Olesen et al., 2010a). Human trials show a uniform perception of thermal stimuli from the stomach to the jejunum with different reflex responses evoked by the stimuli (Villanova et al., 1997). In a previous study, the temperature of recirculating water was continuously measured inside a balloon positioned in the esophagus (Drewes et al., 2003). The model has been used in many studies unraveling pain mechanisms in patients and has recently been used in the

rectum (Drewes and Gregersen, 2006; Brock et al., 2008).

An advantage is that the temperature stimuli showed a linear stimulus-response relationship, demonstrating validity of the model. Accordingly visceral temperature models have proven to be valid in trials with analgesics (Staahl et al., 2006a; Arendt-Nielsen et al., 2009).

The limitation with this method is that uncertainty in pain assessments as a result of fast increase in temperature (1.5°C/min) has been demonstrated, and it has been proposed that individual differences in reaction time could affect the accuracy of rating (Olesen et al., 2010a). Consequently, in future studies, a slower temperature increase has been recommended (Olesen et al., 2010b).

4. Models Evoking Hyperalgesia. Visceral hyperalgesia has been induced by, for example, acid, capsaicin, and glycerol (Drewes et al., 2003b; Hammer and Vogel-sang, 2007; van den Elzen et al., 2009). Acid perfusion of the esophagus is the most widely used chemical stimulus inducing both peripheral and central sensitization as generalized hyperalgesia (Sarkar et al., 2001; Drewes et al., 2003a).

Tissue injury generates release of multiple molecules acting synergistically to produce inflammatory responses and hyperalgesia (Kidd and Urban, 2001). To mimic this situation, it may be necessary to use a mixture of chemical substances with diverse effects on the tissue. Such different cellular interaction sites of acid and capsaicin have been proposed in which the acid targets the TRPV1 extracellularly, whereas the capsaicin targets TRPV1 predominantly intracellularly (Welch et al., 2000). This method of combining chemicals has also been applied in human studies (Brock et al., 2009a; Olesen et al., 2009b, 2010a).

Advantages with these methods are that duration and magnitude of hypersensitivity is related to exposure area or dose of the chemicals (Sarkar et al., 2000, 2001; Drewes et al., 2005). Most of the studies on visceral hyperalgesia have demonstrated increased pain in response to one or more modalities after experimentally induced sensitization by chemicals (Sarkar et al., 2001, 2003; Drewes et al., 2003a; Hobson et al., 2004; Pedersen et al., 2004; Frøkjær et al., 2005; Sami et al., 2006; Willert et al., 2007; Brock et al., 2009a).

However, one limitation is that it has been demonstrated that the response to acid is highly variable the first time a healthy volunteer is exposed to esophageal acid perfusion compared with the second time (Olesen et al., 2009d). Therefore, in drug studies, it is recommended to have a training session, where the subjects are introduced and exposed to chemical perfusion. Another limitation is that a direct comparison between studies investigating visceral hyperalgesia is difficult, because different doses of chemicals have been applied to various visceral organs.

VI. Experimental Pain Modulation

A. Conditioned Pain Modulation

Pain is a complex phenomenon that is modulated by different endogenous inhibitory and facilitatory mechanisms. The conditioning stimuli that activate DNIC have been shown to decrease the activity of rostral ventromedial medulla (RVM) ON cells (Hernández et al., 1994). Moreover, DNIC reduces the activity of convergent dorsal horn neurons through activation of opioid receptors (Willer et al., 1990; Le Bars et al., 1992a; Bouhassira et al., 1993). Animal studies also suggest that DNIC analgesia is mediated by the catecholaminergic, serotonergic, and opioid neuronal systems (Le Bars et al., 1981), and morphine can both inhibit and facilitate the DNIC-phenomenon (Le Bars et al., 1992b). Nevertheless, these studies were performed in different animal species, and the mode of opioid action and DNIC therefore remains controversial.

Assessing CPM (the human term for DNIC) most likely reflects the balance between descending inhibition and facilitation. The concept of CPM is that a tonic nociceptive stimulus (conditioning stimulus) inhibits pain induced by another nociceptive stimulus (test stimulus)—“pain inhibits pain.” The best effect is obtained if the test stimulus is applied extrasegmentally to the conditioning stimulus (Le Bars et al., 1979a,b).

CPM has been widely investigated using several stimulation modalities (Wilder-Smith et al., 2004; Pud et al., 2009; Moont et al., 2010; Olesen et al., 2010b; Treister et al., 2010; Brock et al., 2012), usually by applying two concomitant remote noxious stimuli (e.g., ischemic pain, heat, chemically induced pain, electrical induced pain, physically induced muscle pain, or cold pressor test) (Popescu et al., 2010). The most commonly used paradigm to induce CPM is the cold pressor test (Pud et al., 2009).

CPM responses can be quantified by psychophysical measures (Pud et al., 2009), somatosensory evoked brain potentials (Arendt-Nielsen and Gotliebsen, 1992), or nociceptive reflexes (Willer et al., 1990). A study by Moont et al. (2011) demonstrated increased activity in the orbitofrontal cortex and amygdala as well as reduced activity in, among others, the anterior cingulate cortex (Moont et al., 2011). The anterior cingulate cortex in particular is frequently involved in modulation of pain and analgesia (Willoch et al., 2003; Sprenger et al., 2011), and a coupling between this brain structure and the descending pain control system has been demonstrated to be modulated by the opioid antagonist naloxone in humans (Sprenger et al., 2011). A study by Willer et al. (1990) showed that naloxone blocked the CPM effect induced by painful thermal (46°C) conditioning stimuli (Willer et al., 1990), whereas naloxone did not block the CPM induced by the cold pressor test (Edwards et al., 2004) or by muscle pain (Graven-Nielsen et al., 2002).

B. Summation

Increasing pain in response to a series of stimuli (summation) reflects the first phase of “wind-up” in animal studies. Various modalities have been used to induce temporal summation of skin pain: heat (Granot et al., 2006), cold (Mauderli et al., 2003), mechanical pressure (Nie et al., 2006), and electrical stimulation (Arendt-Nielsen et al., 2000c). Temporal and spatial summation evoked experimentally in the skin reflects a central nervous system modulation of the response, and a number of drugs can block these phenomena (Dirks et al., 2002; Hughes et al., 2002; Koppert et al., 2003b). Temporal summation is believed to mimic neuropathic pain conditions because a likely contribution of central sensitization to neuropathic pain has been demonstrated (Woolf, 2011).

Intramuscular electrical stimulation can be used to assess the efficacy of temporal summation in muscles (Graven-Nielsen et al., 2000). Moreover, increased temporal summation is found during experimentally induced muscle hyperalgesia (Nie et al., 2006). In a study with patients with sigmoidostomy, it was demonstrated by use of repeated visceral stimuli that pain summation thresholds were significantly lower than the threshold in response to single-burst stimuli, indicating the importance of central, temporal summation for visceral pain (Arendt-Nielsen et al., 1997).

C. Thermal Stimulation

It has been shown that concurrent applications to the skin of spatially adjacent bands of innocuous warm and cool stimuli can elicit a noxious sensation (Leung et al., 2005). The frequency and intensity of painful sensations was directly related to the magnitude (i.e., 5–25°C) of the difference of the temperature between the warm and cold bars of the grill (Bouhassira et al., 2005). Two central mechanisms may mediate the painful grill illusion: 1) spatial summation in the warm sense and 2) spatial summation/integration of cold and warm channels (Defrin et al., 2008). Others have also addressed the possibility that there could be a central role involved in the thermal grill illusion (Craig and Bushnell, 1994). However, this remains unclear (Li et al., 2009).

D. Chemical Stimulation

Chemical stimulations can also lead to central sensitization. For example, induction of central sensitization has been demonstrated after intradermal injection of capsaicin (Simone et al., 1989; Koltzenburg et al., 1992; LaMotte et al., 1992). Therefore, intradermal capsaicin has also been used as a neuropathic pain model (Aykanat et al., 2012). Human studies of visceral hyperalgesia induced by perfusing the esophagus with acid, capsaicin, or a combination have demonstrated central sensitization (Sarkar et al., 2000; Brock et al., 2009a; Olesen et al., 2009b). These methods are described previously in section V.C.4.

E. Long-Term Potentiation/Depression

Long-term potentiation (LTP) and subsequently increased synaptic strength in nociceptive pathways shares several features with hyperalgesia and has been proposed to be a cellular mechanism of pain amplification in acute and chronic pain states. Hence, analysis of the molecular mechanisms underlying the generation and maintenance of central sensitization and LTP indicates that these mechanisms share distinct similarities (Sandkühler, 2010). Methods of experimentally inducing secondary hyperalgesia possibly involving LTP in rodents have previously been described in detail (Ruscheweyh et al., 2011). These methods include electrical nerve stimulation or such natural noxious stimulations as skin incision, chemical injury, and thermal injury (Ruscheweyh et al., 2011). The conditioning electrical stimulation of high-frequency stimulation of the same type that induces LTP in rodents has in humans been shown to induce long-lasting potentiation of pain perception (Ruscheweyh et al., 2011). In humans, electrical C fiber stimulation can be applied transcutaneously using specialized electrodes (Klein et al., 2004). Body regions such as the lower back and forearm are preferable because of their large receptive fields, allowing multiple electrode placements within the same receptive field (Jung et al., 2011).

Electrical low-frequency stimulation of nociceptive skin afferents has the opposite function and reliably induces long-term depression (LTD) of pain. It has been suggested that reduction of sharp pain points to A δ fiber-mediated LTD (Rottmann et al., 2010). LTD can be induced not only in the stimulation site but also within a certain area of the receptive field (Jung et al., 2009; Rottmann et al., 2010). These findings could be important for electrostimulation in clinical use in humans (Jung et al., 2011).

It has been demonstrated that low frequency stimulation of A δ fibers can reverse high-frequency-induced LTP (depotentialization), but the opposite is not possible (Ikeda et al., 2000). LTP and LTD share common properties, and both lead to an activation of NMDA receptors and increase in postsynaptic calcium channels, but during LTP, Ca²⁺ reaches high levels and preferentially activates a protein kinase. On the other hand, during LTD, lower Ca²⁺ levels are achieved, and this preferentially activates a protein phosphatase (Bear and Malenka, 1994).

VII. Pain Assessment

Pain can be measured by qualitative and quantitative methods, and these can be subjective and/or objective. Qualitative methods evoke responses that use categorical measures. For example, the responses "pain" and "no pain" indicate whether the drug or modulation inhibits pain or not (Curatolo et al., 2000a). The main limitation with categorical measures is that nonparametric statis-

tical methods shall be applied, giving the measures less sensitivity for detecting analgesic responses. Therefore, responses evoked by quantitative methods are usually applied. The different quantitative methods are described below.

A. Psychophysical Methods

Psychophysics quantitatively investigates the relationship between physical stimuli and the sensations and perceptions they give. A central concept in psychophysics is that of thresholds. In pain research, several types of thresholds have been used (Handwerker and Kobal, 1993).

1. One-Dimensional Pain Assessment Tools. Psychophysical methods of pain assessment are based on a volunteer's subjective pain experience. Frequently used methods are one-dimensional pain scales, such as verbal rating scales (e.g., none, mild, moderate, severe, or unbearable); VASs (e.g., 10-cm line with anchor points at each end), and numerical rating scales (Caraceni et al., 2002). These scales provide simple, efficient, and minimally intrusive measures of pain intensity that have been used widely in clinical and research settings in which a quick index of pain intensity is required and to which a numerical value can be assigned (Katz and Melzack, 1999). However, such rating scales can also be used to score dimensions of the pain experience other than intensity (e.g., the unpleasantness of pain stimuli). For threshold determinations, intensity of the stimulus is gradually increased, and drug effect can be quantified by recording the stimulus intensity at which the subject begins to perceive the stimulus (stimulus detection threshold), the stimulus intensity at which the stimulus perception becomes painful (pain detection threshold), or the stimulus intensity at which the pain is perceived as intolerable (pain tolerance threshold) (Brennum et al., 1992).

A limitation is that the one-dimensional pain tools assess only a limited part of the experienced pain. Therefore, to grasp the full complexity of the pain experience, results from several assessments must be used to give a more complete picture of the evoked pain experience (Giordano et al., 2010). For example, pain intensity, pain relief, and psychological distress are independent subjective measures that interact in complex ways to determine the perception and experience of pain (see Fig. 8) (Frampton and Hughes-Webb, 2011).

2. Multidimensional Pain Assessment Tools. Multidimensional pain measurement tools can be used to assess a wider pain experience. The McGill Pain Questionnaire provides estimates of the sensory, affective, and evaluative dimensions of pain. It consists of 78 pain adjectives arranged into 20 groups further arranged into sets of words describing the different dimensions in pain (Melzack, 1975; Katz and Melzack, 1999). The McGill Pain Questionnaire has been developed for other languages and has proven consistency as a cross-cultural

pain assessment tool (Drewes et al., 1993). The McGill Pain Questionnaire seems to provide a more sensitive measurement of pain than does a simple VAS (Katz and Melzack, 1999). A reason could be that patients can be more precise in describing their experiences by selecting appropriate descriptors. This increased ability of the McGill Pain Questionnaire to detect differences in pain at the low end of the pain scale most likely is a function of the multidimensional nature of the McGill Pain Questionnaire and the large number of descriptors from which to choose (Katz and Melzack, 1999). A short-form McGill Pain Questionnaire was developed for use in specific research settings where time is limited but more information is needed than that provided by the one-dimensional pain tools. In addition, the Descriptor Differential Scale was developed using sophisticated psychophysical techniques and was designed to measure separately the sensory and unpleasantness dimensions of pain (Katz and Melzack, 1999).

A limitation of the multidimensional pain tools is that they can be more comprehensive. For example, the discriminative capacity of the McGill Pain Questionnaire is limited when the patient presents with high levels of anxiety or psychological disturbance (Melzack, 1975). Moreover, in specific comprehensive research settings, time can be limited, making a one-dimensional tool more appropriate.

B. Neurophysiological Methods

1. *Magnetic Resonance Imaging.* Magnetic resonance imaging (MRI) allows imaging of both brain structure and activity. Brain activity measured by MRI has most commonly been acquired by the blood oxygenation level-dependent technique, which is based on different paramagnetic properties of oxy- and deoxyhemoglobin in the blood. Lately, other techniques, such as arterial spin labeling and signal enhancement by extravascular water protons, have been applied (Chen et al., 2011). A clear advantage of functional MRI (fMRI) is that it operates in a noninvasive and nonradioactive environment, allowing subjects to be studied repetitively (Frøkjær et al., 2011). Functional MRI has been used to detect analgesic effects (Borsook and Becerra, 2006; Iannetti and Wise, 2007; Borsook et al., 2011).

The limitation is that the temporal resolution of fMRI is clearly inferior to electroencephalography (EEG) and magnetoencephalography (MEG), meaning that fMRI is not a specific tool for investigating the primary neuronal activity directly related to the painful stimuli (first few hundred milliseconds after stimulus). In contrast to PET studies, a limitation in fMRI studies is the lack of information regarding neurotransmitters or involved receptors. Functional MRI has an excellent spatial resolution (2–5 mm), especially in the more superficial layers, but limitations are seen in the deeper structures, such as the brainstem and thalamus, as a result of pulsation arti-

facts (Frøkjær et al., 2011). Another practical limitation is that MRI scanners are expensive.

2. *Single Photon Emission Computed Tomography and Positron Emission Tomography.* Single photon emission computed tomography (SPECT) and PET are nuclear imaging techniques that can trace radiolabeled molecules injected into the bloodstream. The distribution, density, and activity of receptors in the brain can thereby be visualized. For example, in vivo functional imaging by means of PET is a method for providing a quantitative measurement of opioid receptor-mediated signaling in the central nervous system. A decrease in opioid receptor availability related to acute pain has been demonstrated (Henriksen and Willoch, 2008). PET and SPECT have been used for imaging of the opioid system and allow precise pharmacokinetic and pharmacodynamic measurements (Lever, 2007).

Limitations are that the temporal resolution of SPECT and PET is poor (minutes) compared with EEG, and group analysis is needed for meaningful results (Frøkjær et al., 2011). Moreover, the subjects receive radiation, and the expense for the synthesis and the PET ligand is high. Finally, the experimental setup and the choice of tracer may affect the results and explain any divergence in findings (Henriksen and Willoch, 2008).

3. *Electroencephalography.* EEG is a method to assess electrical activity in the brain generated by firing between neurons. The activity can be recorded as evoked potentials (EPs) after painful stimuli (Fig. 9). The analysis of EPs is typically based on an averaging process including multiple stimuli, because the amplitudes of the single EPs tend to be low compared with spontaneous EEG activity. The EPs can then be analyzed in terms of amplitude and latency and by more advanced analysis based on time-frequency analysis, classification methods, and inverse modeling of brain sources. EEG may be used to study pain processing and to identify alterations of pain processing in different patient groups or due to pharmacological intervention, as illustrated in Fig. 9. It has consistently been shown that EPs are affected by analgesics (Banoub et al., 2003; Staahl et al., 2011).

The main limitation is the relatively poor spatial resolution. However, various inverse modeling algorithms and signal decomposition procedures have overcome this limitation to some extent and ongoing research in this field holds promise for further improvements of the methods (Lelic et al., 2009; Lelic et al., 2011). Moreover, although multichannel EEG, cerebral EPs, and inverse modeling offers a noninvasive approach to study brain activity, it must not be overlooked that the position of the calculated dipolar source does not represent the accurate position but more the “center of gravity” of brain activity (Lelic et al., 2011). Any stimulus applied probably activates nociceptive and non-nociceptive pathways. Therefore, the electrophysiological response may

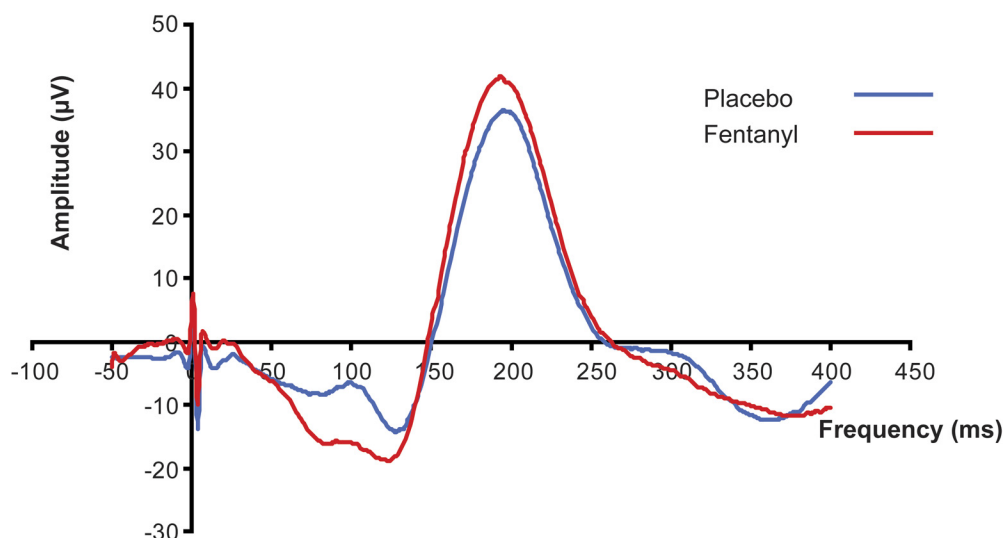

FIG. 9. Fentanyl effect on evoked potentials. An example of an evoked potential recorded at Cz electrode for placebo (blue) and fentanyl (red) with electrical stimulation at the median nerve. Treatment with transdermal fentanyl significantly increased the amplitude at 200 ms compared with placebo. Recordings were performed at baseline (before treatment) and 24, 48, and 72 h after application of either fentanyl or placebo. Results are shown after 72 h.

be a result of both components, and the results should always be correlated to the subjective pain intensity. However, EPs provide important complementary information in pharmacological research (Curatolo et al., 2000a).

4. Magnetoencephalography. MEG is a technique for mapping brain activity by recording magnetic fields produced by electrical currents in the brain (Smith et al., 2011). The electrical currents (as measured by the EEG) accompanying brain activity result in small magnetic fields. These fields can be measured in magnetic shielded rooms by superconducting detectors. MEG has added knowledge to the characterization of the somatotopic organization of the primary and secondary somatosensory areas as well as the association between pain and cortical reorganization in somatic and neuropathic pain studies (Sharma et al., 2009). MEG has been used to explore the effects of various psychopharmacological agents on resting brain, sensory, and cognitive processing and may be used for analgesic evaluations as well (Kähkönen, 2006; Iannetti and Wise, 2007).

Limitations are that the MEG is an expensive and very technically demanding technique that is available only in a few specialist centers. Furthermore, it is limited by its incapacity to resolve radial currents generated by deep brain sources (e.g., in the cingulate cortex), which are of major importance in pain processing (Lelic et al., 2011).

C. The Nociceptive Withdrawal Reflex

A nociceptive input followed by secondary processing in the spinal cord initiates generation of the withdrawal reflex. In human, electrical stimulation is frequently used to elicit the reflex but laser stimulation and heat stimulations have been used as well (Andersen et al.,

2006; Mørch et al., 2007). The reflex can be evoked by stimulation of the sural nerve at the ankle. During the after-withdrawal, the electromyogram is recorded from the tibialis or biceps muscle. Modulation of the reflex threshold or the reflex size can be used as outcome measures. A high correlation between the pain intensity stimulus-response curve and the reflex size stimulus-response curve has led to the suggestion that the reflex can be used as an objective measure of experimental pain (Willer, 1977). The model of nociceptive withdrawal reflex has mostly been used for pharmacological evaluation in animals (Peterbauer et al., 2008), but human studies have found analgesic effects in this model as well (Poulsen et al., 1995; Sandrini et al., 2005).

A limitation is that electrical stimulation, which is frequently used to elicit the reflex, explores only a single dimension of the complex sensory and affective experience of pain (Neziri et al., 2010). Therefore, it cannot be used as a measure of the complex pain experience on its own (Gracely, 1999). On the other hand, the relative robustness of the tests may be used advantageously when the influence of confounding parameters is limited. This may be the case for pharmacological studies conducted on small samples, in which it may be difficult to control for confounding factors (Neziri et al., 2010). Moreover, it has been demonstrated that sedation can affect the reflex threshold (Petersen-Felix et al., 1996). This should be considered when evaluating analgesic effects because many analgesics have sedative effects as well.

D. Referred Pain Area

Referred pain is defined as pain felt in an area other than the stimulation site and can be assessed as the size of the area (Fig. 3) (Curatolo et al., 2000a). Referred pain

is evoked by different pain modalities (e.g., electrical, mechanical, cold and heat) in muscle and viscera, and, as outlined in section II.A.2, it can be considered a proxy for the central pain processing (Drewes et al., 2003b; Olesen et al., 2010a). An increase in referred pain areas after, for example, acid perfusion can be used to monitor central sensitization (Drewes et al., 2005; Drewes and Gregersen, 2006).

One limitation is that a large variation in the reporting of referred pain areas has been demonstrated. This large variation could be due to difficulties of reporting the phenomenon (Olesen et al., 2010a). The larger S.D. for the referred pain areas will result in the need of large sample sizes for detection of analgesic effects (Staahl et al., 2006b).

VIII. Analgesic Assessment by Experimental Human Pain Models in Healthy Volunteers

Experimental pain models are useful in evaluation of the mechanisms of analgesics. The focus in this review is analgesic assessment by human experimental pain models in different patient groups. However, for overview purposes and to attain a deeper discussion between findings from healthy volunteers and those from patient studies, this section provides a brief summary on how the efficacies of analgesics have been assessed in healthy human volunteers using experimental pain models. For more detailed reviews, the reader is referred to previous publications (Staahl et al., 2009a,b). Dosing regimens and mechanistic aspects are discussed briefly at the end of each section. To be able to illustrate the importance of various experimental designs in discussion, only studies of analgesics that have been tested in at least five different trials were included. Moreover, seven was regarded as the minimum sample size for the studies included in this section.

A. Nonopioids

1. Nonsteroidal Anti-Inflammatory Drugs and Acetaminophen. Different NSAIDs and acetaminophen (paracetamol) have been evaluated in experimental human pain models in healthy volunteers.

a. Acetylsalicylic acid (aspirin). Acetylsalicylic acid has been tested extensively in the past. Topical as well as systemic preparations have been used.

i. Skin, nasal, and dental mucosa. Acetylsalicylic acid has been tested against pain from radiant heat, electrical stimulation, nasal gaseous CO₂ stimulation, and infusion of low pH solutions (Cruccu et al., 1982; Schaffler et al., 1987; Bromm et al., 1991; Steen et al., 1996). Kobal et al. (1990) found only significant modulation of the evoked potentials and not subjective pain ratings after nasal gaseous CO₂ stimulation. Supporting this Schaffler et al. (1987) found good effect of acetylsalicylic acid on the evoked vertex potential from radiant heat stimulation.

ii. Skin hyperalgesia. Pain from repeated mechanical impact of the interdigital web is a classic model for detecting analgesia from NSAIDs, and this model is sensitive to analgesia from acetylsalicylic acid (Forster et al., 1988). Topically applied acetylsalicylic acid was efficacious in tonic pain from cutaneous infusion of a low pH solution (Steen et al., 1996). Allodynia and hyperalgesia from pinprick after capsaicin was diminished by acetylsalicylic acid, whereas heat hyperalgesia was unaffected (Schmelz and Kress, 1996). Imaging has been used for pain assessment of the analgesic effect of acetylsalicylic acid in the UVB pain model, where differences in the brain structures responsible for attenuation of pain and hyperalgesia were found (Maihöfner et al., 2007).

iii. Muscle. Tonic muscle pain, such as ischemic muscle pain in one study, was unaffected by acetylsalicylic acid when measured by various subjective ratings (Posner, 1984).

iv. Muscle hyperalgesia. Acetylsalicylic acid did not affect delayed-onset muscle soreness (Barlas et al., 2000).

v. Conclusions. The therapeutic dose for weak pain is normally set at 100 to 500 mg, and in most of the experimental trials reviewed here, doses within this range were used, although toward the upper end of the dose range.

b. Ibuprofen. Ibuprofen has often been used as a representative of weak NSAIDs.

i. Skin and nasal mucosa. Ibuprofen has been tested against various types of electrical pain and found to be effective. To be able to detect analgesia, electrical pain stimulation needs to be intense and evoke pain intensity well above the pain detection threshold (Sandrini et al., 1992; Oertel et al., 2008). Here, as seen with other weak analgesics, only evoked potentials and not subjective pain ratings changed after drug administration (Kobal et al., 1994). Pain from argon laser stimulation was also attenuated by ibuprofen. This could be because the repeated strong laser pulses caused sensitization of the skin, leading to a model of skin hyperalgesia (Nielsen et al., 1990).

ii. Skin hyperalgesia. Ibuprofen has been tested twice against hyperalgesia after freeze lesions (Kilo et al., 1995; Chassaing et al., 2006). Topical application of ibuprofen showed an effect in the primary hyperalgesic area to pinprick (von Frey hair) demonstrating a local effect of the drug, whereas systemic administration decreased both primary and secondary hyperalgesia to pinprick, demonstrating both central and peripheral antihyperalgesic mechanisms of ibuprofen (Chassaing et al., 2006). In the study by Kilo et al. (1995), only mechanical hyperalgesia was sensitive to ibuprofen analgesia. Capsaicin-induced allodynia to stroking was not affected by ibuprofen (Kilo et al., 1995). Repetitive pinching of the interdigital web has also been used in trials of ibuprofen; however, results were inconsistent

for this model (Kilo et al., 1995; Petersen et al., 1997). UVB radiation of the skin promotes hyperalgesia to heat and mechanical hyperalgesia, which was decreased by ibuprofen (Bickel et al., 1998; Sycha et al., 2003). The burn injury model has also been applied in the testing of ibuprofen, where pain in response to brushing but not to punctate stimuli was reduced in the secondary hyperalgesic area (Petersen et al., 1997). In the model of menthol-induced hyperalgesia, ibuprofen was ineffective (Altis et al., 2009).

iii. Muscle. Eccentric jaw exercise caused muscle fatigue and low levels of postexercise pain and soreness that was attenuated by ibuprofen (Svensson et al., 1997). Pain from statically applied pressure was also affected by ibuprofen (Kilo et al., 1995).

iv. Models that induce endogenous pain modulation. The cold pressor test has been tested with ibuprofen and found insensitive (Jones et al., 1988). The test has a known sensitivity to many opioids, but apparently the test is not suitable for testing weak NSAIDs (Poulsen et al., 1996a; Eckhardt et al., 2000; Schulte et al., 2003; Grach et al., 2004; Enggaard et al., 2006; Pud et al., 2006).

v. Conclusions. The therapeutic dose for treatment of weak pain is 200 to 400 mg (three to four times daily); however, rheumatic pain needs doses ranging from 300 to 600 mg (three to four times daily). The experimental studies enrolled in this review applied doses ranging from 400 to 800 mg. Two studies found equal effect of 400 and 800 mg in hyperalgesia, suggesting a plateau for the dose-response profile (Nielsen et al., 1990; Kilo et al., 1995). However, another study applying the same doses found that evoked potentials responded in a dose-related manner, so a plateau of the effect is probably not seen with 400 mg (Kobal et al., 1994).

Some studies have found a better sensitivity of evoked potentials compared with methods that apply subjective pain measures (Kobal et al., 1990; Bromm and Treede, 1991; Bromm et al., 1991). A possible explanation could be that the main analgesic effect is in the central nervous system (Eisenach et al., 2010).

c. Ketorolac.

i. Skin and nasal mucosa. Heat pain was unaffected by intrathecally administered ketorolac (Eisenach et al., 2010).

ii. Muscle. Injection of hypertonic saline into the masseter muscle showed that ketorolac attenuated trigeminal pain (Bendixen et al., 2010). Ischemic pain induced by a tourniquet was attenuated by ketorolac (Benedetti et al., 2003).

iii. Skin hyperalgesia. Areas of hyperalgesia and allodynia from the heat-capsaicin model were unaffected by intrathecal ketorolac (Eisenach et al., 2010). In the same study, the UVB-burn model was applied and was unaffected by ketorolac (Eisenach et al., 2010). The same study applied heat rekindling after the UVB-burn induction, and here it was shown that intrathecal ketorolac

had a small but significant effect on the area of allodynia but not on the area of hyperalgesia. Furthermore, this group tested the UVB/heat rekindling model with intravenous ketorolac and found effects on areas of hyperalgesia as well as areas of allodynia (Eisenach et al., 2010).

iv. Muscle hyperalgesia. Pain and hyperalgesia from intramuscular capsaicin was unaffected by ketorolac (Kumar et al., 2006).

v. Models that induce endogenous pain modulation. One study found that ketorolac was ineffective on experimental cold pressor test in the overall study population but found significant response when examining women as a subgroup (Compton et al., 2003).

vi. Conclusions. In general, ketorolac is potent in the reviewed models, but the trial by Eisenach et al. (2010) shows that the spinal effect of ketorolac is limited in the administered dose.

d. Acetaminophen (paracetamol).

i. Skin and nasal mucosa. Acetaminophen has been tested against pain from laser and electrical stimulation of the skin. The model involving laser was sensitive to acetaminophen (Nielsen et al., 1991, 1992). Conflicting results exist for electrically induced pain. Pain from repeated electrical stimulation mimicking the previously mentioned central integration of the response was unaffected by acetaminophen. In the study in which the electrical pain was decreased by acetaminophen, modulation was most distinct for the evoked brain potentials compared with the subjective pain rating (Bromm et al., 1992; Olesen et al., 2007). Tonic and phasic pain from stimulation of the nasal mucosa with gaseous CO₂ and dry air has been tested. For the phasic pain induced by gaseous CO₂ stimulation, only evoked potentials and not subjective pain ratings were affected by drug administration. The subjective pain ratings were affected for the more tonic pain induced by dry air (Renner et al., 2007).

ii. Skin hyperalgesia. Pain and hyperalgesia from the freeze lesion model was unaffected by acetaminophen. Furthermore, acetaminophen has been tested against hyperalgesia evoked by continuous electrical stimulation. Here the ongoing pain was unaffected, whereas the hyperalgesia was decreased (Filitz et al., 2008; Bandschapp et al., 2011). However, there have been conflicting results in this model, because no effect could be demonstrated in a recent study of acetaminophen (Dusch et al., 2010).

iii. Muscle. Pain from pressure algometry was not affected in two studies (Romundstad et al., 2006; Olesen et al., 2007). Furthermore, pain from intramuscular infusion of hypertonic saline has been tested but was not decreased by acetaminophen (Olesen et al., 2007). Accordingly, a model involving both single and repeated intramuscular electrical stimulation was not sensitive to acetaminophen (Olesen et al., 2007).

iv. Models that induce endogenous pain modulation. Stimulating the endogenous pain system via cold

water immersion of the hand reinforced acetaminophen analgesia (Pickering et al., 2008).

v. Conclusions. The reviewed studies applied doses at and above the therapeutic range. It is noteworthy that intravenous dosing seem to give a better effect in the electrical hyperalgesia model, where even 2 g p.o. showed no significant analgesia (Filitz et al., 2008; Dusch et al., 2010; Bandschapp et al., 2011).

2. N-Methyl-D-aspartate Antagonists.

a. Ketamine. Ketamine has pronounced side effects preventing wide clinical use as an analgesic. However, ketamine is used to some degree in difficult clinical cases and has been intensively investigated as a “model drug” because of the substantial scientific interest in the NMDA receptor.

i. Skin. Ketamine has been tested against sensations and pain from heat, cold, and electrical skin stimulation. Results are conflicting, because the effect of ketamine can be detected in some trials with these acute models and not in others applying the same type of stimuli (Warncke et al., 1997; Wallace et al., 2002a,b; Pöyhä and Vainio, 2006). However, an effect was detected when applying electrical pain (particularly strong pain intensities) and heat pain in some studies (Arendt-Nielsen et al., 1996; Koppert et al., 2001; Schulte et al., 2003). Pricking “first pain” from laser stimulation was unaffected by ketamine (Arendt-Nielsen et al., 1995), whereas another study found effect on the affective components of heat pain and “second pain” after thermal stimulation (Hughes et al., 2002; Strigo et al., 2005). Pain from repeated and continuous electrical stimulation was sensitive to ketamine (Arendt-Nielsen et al., 1996; Koppert et al., 2001). A study analyzing drug effects in relation to drug plasma concentrations found a more pronounced effect toward heat pain than electrical pain (Sigtermans et al., 2009). One study analyzed the cerebral effects of ketamine and found dose-dependent effects on pain processing to heat pain. This study also found that pain unpleasantness decreased more than pain intensity, possibly reflecting the effects in insula and anterior cingulate cortex (Sprenger et al., 2006).

ii. Skin hyperalgesia. Hyperalgesia to stroking and pinprick were affected by systemic but not locally applied ketamine (Sethna et al., 1998; Gottrup et al., 2000a,b; Wallace et al., 2002b). One study evaluated the hyperalgesia with laser heat and electrical stimulation; only the electrical stimulation in the secondary hyperalgesic area was sensitive to the drug (Andersen et al., 1996). Hyperalgesia evoked by burn injury is decreased by ketamine, and substantial effects could be seen on hyperalgesia in response to pinprick and allodynia in response to stroking (Ilkjaer et al., 1996; Warncke et al., 1997; Schulte et al., 2004). Allodynia and hyperalgesia from continuous electrical stimulation were all affected by ketamine (Koppert et al., 2001), which should be expected because the inflicted pain is strong and long-lasting, and it probably activates the NMDA receptors.

iii. Muscle and joints. Muscular pain in response to electrical stimulation, pressure pain, and hypertonic saline infusion was decreased after ketamine treatment (Arendt-Nielsen et al., 1995, 1996; Schulte et al., 2003). Pain elicited by glutamate injection into the temporomandibular joint was inhibited by local coinjection of ketamine, showing peripheral effects in the trigeminal pain system (Alstergren et al., 2010).

iv. Muscle hyperalgesia. Mechanical hyperalgesia after glutamate injection in the masseter muscle was attenuated by intramuscular ketamine, showing an effect of ketamine on the peripheral nerves, where NMDA receptors have also been demonstrated (Cairns et al., 2006).

v. Viscera. Pain from visceral distension was also decreased by ketamine (Strigo et al., 2005).

vi. Visceral hyperalgesia. Hyperalgesia to electrical pain has been induced in the esophagus by infusion of hydrochloric acid. This study showed that ketamine was able to both prevent the development of hyperalgesia and reverse hyperalgesia already developed (Willert et al., 2004).

vii. Models that induce endogenous pain modulation. One study found that ketamine decreased the endogenous pain inhibitory response. This study also looked into the response to prolonged heat pain stimulation, producing off-set analgesia. Ketamine was not significantly different from placebo in affecting this response (Niesters et al., 2011). A trial applying the “thermal grill” found that ketamine reduced the “paradoxical pain” but not the normal heat pain sensations and non-painful heat sensations (Kern et al., 2008).

viii. Conclusions. The ability of ketamine to reverse hyperalgesia seems to depend on the model and tissue wherein the hyperalgesia is induced. Warncke et al. (1997) found that several of the decreased hyperalgesic responses to brushing and pinprick returned to the original state 15 min after ketamine administration. This could very well be caused by the short half-life of ketamine, meaning that the plasma level was markedly reduced after 15 min. It illustrates the importance of testing at time points where the drug is present in the body. Wallace et al. (2002b) infused mean amounts of 0.33, 0.52, and 0.82 mg/kg and accordingly found more pronounced effects than Sethna et al. (1998), who used a lower dose.

The NMDA receptor is mainly activated under strong or repeated stimulation (Arendt-Nielsen et al., 1995; Dickenson, 1995); accordingly, temporal and spatial summation (central integration of the afferent barrage via the NMDA receptor) is likely to be affected by ketamine (Arendt-Nielsen et al., 1996; Koppert et al., 2001). In general, models involving hyperalgesia induce long-lasting and strong pain and therefore could demonstrate analgesia from ketamine. Deep pain from muscle and viscera was affected more than superficial pain (Segerdahl et al., 1994; Strigo et al., 2005). Wallace et al.

(2002a,b) have tried to administer ketamine both before and after intradermal injection of capsaicin. They found that to provide analgesia, the drug needed to be administered before the induction of hyperalgesia. This probably means that development of hyperalgesia was prevented rather than reversed. Hyperalgesia from application of capsaicin to the skin was sensitive to ketamine when evaluated by stroking and pinprick (Sethna et al., 1998; Wallace et al., 2002b). This effect seemed to be central, because subcutaneous administration failed to attenuate the hyperalgesia and spontaneous pain (Gottrup et al., 2000a,b).

3. Adjuvant Analgesics.

a. Gabapentin and pregabalin. Gabapentin and pregabalin are anticonvulsive agents believed to have similar mechanisms of action and are therefore reviewed together. Both drugs are widely used in neuropathic pain.

i. Skin. Heat pain and pain from stimulation with von Frey filaments have been tested with gabapentin. The subjective pain ratings were unaffected by gabapentin, but in fMRI studies, activations in the bilateral insula were modulated (Dirks et al., 2002; Iannetti et al., 2005). On the other hand, a recent electrophysiological study showed that pregabalin did not change location of electrical brain sources in response to visceral stimulation, and the effects of pregabalin are probably mediated primarily through subcortical mechanisms (Olesen et al., 2011b).

ii. Skin hyperalgesia. Several groups have tested gabapentin against hyperalgesia and allodynia from cutaneous capsaicin stimulation. All studies showed analgesic effect on at least one hyperalgesia parameter (Dirks et al., 2002; Gottrup et al., 2004; Iannetti et al., 2005). One study showed no effect on subjective pain ratings, but only on brainstem activation in an fMRI study (Iannetti et al., 2005). One study applied the capsaicin model in a multiple dose regimen and surprisingly found no significant effect of gabapentin (Wallace and Schulteis, 2008). Inflammation from UVB radiation was unaffected by gabapentin (Gustorff et al., 2004). In the model of menthol-induced hyperalgesia, pregabalin was ineffective (Altis et al., 2009). Areas of allodynia and pinprick hyperalgesia from continuous electrical stimulation were reduced after multiple doses of pregabalin (Chizh et al., 2007). On the other hand, in a recent translational study, temporal summation was not attenuated by pregabalin in either rodents or humans, and the effect of pregabalin in neuropathic pain is probably not predominantly due to modulation of temporal summation (Arendt-Nielsen et al., 2011).

iii. Muscle. Arendt-Nielsen et al. found that pain from infusion of hypertonic saline was attenuated after gabapentin (Arendt-Nielsen et al., 2007b). However, these findings were contrasted in a study using the same stimulation and assessment methods, even with application of higher and multiple doses (Segerdahl, 2006).

iv. Models that induce endogenous pain modulation. The cold pressor test, which is sensitive to opioids, was insensitive to gabapentin (Eckhardt et al., 2000).

v. Conclusions. A straightforward dose-response relationship is not apparent for the trials of gabapentin and pregabalin. In the hypertonic saline model, inducing muscle pain, an effect was seen in the study applying the lower dose. Segerdahl (2006) used a single dose of 1200 or 2600 mg distributed over 24 h, whereas Arendt-Nielsen et al. (2007b) found effect of a single dose of 1200 mg. Gottrup et al. (2004) applied a daily dose of 2400 mg p.o. for 15 days but revealed an effect only on allodynia in response to brushing. The study by Dirks et al. (2002), however, applied a rather low dose and found an overall good effect on several pain parameters. In the clinic, this drug needs a slow titration to effect, and it can take weeks for the analgesia to appear. However, this was not reflected by a better sensitivity in trials with multiple dosing regimens, exemplified by the trials from Segerdahl (2006) and Wallace and Schulteis (2008).

b. Lamotrigine. Lamotrigine is an anticonvulsant drug and a sodium-channel antagonist used for the treatment of neuropathic pain.

i. Skin and nasal mucosa. Lamotrigine has been tested against heat pain in the skin and in pain from CO₂ stimulation of the nasal mucosa. The drug generally showed no effects in any of these models (Klamt and Posner, 1999; Petersen et al., 2003; Wallace et al., 2004).

ii. Skin hyperalgesia. Lamotrigine has been tested against capsaicin with and without combination with heat. In these models, no effects were found (Petersen et al., 2003; Wallace et al., 2004).

iii. Models that induce endogenous pain modulation. The cold pressor test, which is sensitive to opioids, was also sensitive to the analgesic effects of lamotrigine (Webb and Kamali, 1998).

iv. Conclusions. Slow up-titration of lamotrigine is used in the clinic to achieve efficient doses without the presence of unacceptable side effects. This was not done in the above trials, and doses that produced profound side effects were applied. However, in most trials, these doses produced no significant analgesic effects (Klamt and Posner, 1999; Petersen et al., 2003).

Adjuvant analgesics have limited effect in physiological pain mechanisms as produced by acute pain models. The effect seems to depend on the reduction of pathological neurotransmitter release, and this could well explain the lack of effect in short-lasting acute pain models (Laughlin et al., 2002). It is noteworthy that lamotrigine decreases pain from immersion of the hand into ice-water. This could be due to the tonic (and relatively long-lasting) nature of the evoked pain in this model, because the membrane-stabilizing effects of lamotrigine would not be expected to induce descending noxious inhibitory control (Webb and Kamali, 1998). The anticonvulsives have been tested extensively in the capsaicin

cin model, where only gabapentin and pregabalin showed effect. Lamotrigine has a clinical effect comparable with that of gabapentin and pregabalin, but apparently the mechanisms of lamotrigine cannot be shown in experimental hyperalgesia (Chizh et al., 2007). It should be stressed that even in experimental models, inducing hyperalgesia, central plasticity is not induced in the same manner and to the same extent as in patients with chronic pain. For instance, up-regulation of calcium channels is unlikely to occur. Therefore, it seems that for the anticonvulsives the experimental pain models applied to healthy volunteers does not seem to be readily translatable into patients.

c. Imipramine. Serotonin and norepinephrine reuptake inhibitors and tricyclic antidepressants are both used in treatment of neuropathic pain, but only imipramine has been tested in more than four studies.

i. Skin and nasal mucosa. Imipramine has been tested in models involving heat, electrical, and laser stimulation of the skin as well as nasal gaseous CO₂ stimulation (Bromm et al., 1986b; Hummel et al., 1994; Poulsen et al., 1995; Sindrup et al., 1998; Enggaard et al., 2001). Electrical stimulation was sensitive to imipramine (Enggaard et al., 2001). Sensations from laser stimulation (reflecting a fast heat stimulus) were unaffected by imipramine, whereas the heat pain intensity was decreased (Poulsen et al., 1995; Sindrup et al., 1998). The rate of the heating in the study by Poulsen et al. (1995) was slow, securing more selective C fiber activation (Le Bars et al., 2001). Sensation to intracutaneous electrical stimulation was decreased by imipramine. The effect was detectable on both subjective pain ratings and in the evoked potential (Bromm et al., 1986b). Poulsen et al. (1995) found a profound effect of imipramine on the reflex threshold and subjective pain ratings to single stimulations, whereas the effect on the repeated stimulations was detected only by the subjective pain rating.

ii. Muscle. Deep pressure pain was decreased by imipramine, but only when the stimulus intensity exceeds the pain threshold (Poulsen et al., 1995; Enggaard et al., 2001).

iii. Viscera. Painful sensations to distension of the esophagus were affected (Peghini et al., 1998).

iv. Models that induce endogenous pain modulation. In contrast to findings from most other analgesics, pain evoked by the cold pressor test was unaffected by imipramine (Enggaard et al., 2001).

v. Conclusions. Most studies applied high doses (100 mg) compared with clinically used doses (≤ 75 mg in chronic pain), and this could be part of the reason for the overall good effect of imipramine in the majority of the studies. However, in the clinical situation, there is often a delay of 1 to 2 weeks before the drug works, and this aspect was not reflected in the models.

The fact that imipramine works through many different analgesic mechanisms may also have contributed to

the effects found in several experimental models. However, the majority of the studies above showed a pain specific action of imipramine with a decrease of sensations at the pain detection threshold or of higher intensity (Poulsen et al., 1995; Peghini et al., 1998; Enggaard et al., 2001).

B. Opioids

Opioids are described in separate sections as short-acting opioids (only sufficient studies of alfentanil and remifentanil exist) and longer acting opioids. It is believed that short-acting opioids are very similar in their modes of action, and this is to some degree reflected in the findings in experimental pain models.

1. Short-Acting Opioids

a. Alfentanil and remifentanil. Alfentanil and remifentanil are short-acting opioids that have been tested in human experimental pain models in healthy volunteers.

i. Skin and teeth. Alfentanil has been tested in several acute models in the skin using, for example, heat, cold, and electrical stimulation (Petersen-Felix et al., 1994, 1996; Luginbühl et al., 2001; Wallace et al., 2002; Olofsen et al., 2005; Schulte et al., 2006). The tested models were generally all sensitive to alfentanil. Remifentanil has been tested against heat and electrical stimulation (Curatolo et al., 2000b; Gustorff et al., 2001; Petersen et al., 2001; Luginbühl et al., 2003). The studies showed a reduction in pain in response to heat stimuli as well as to single and repeated electrical stimulation. The effect of remifentanil on heat pain was furthermore evaluated by positron emission tomography. The study showed a decrease of the pain-induced brain activation and increased brain activity in the cingulo-frontal cortex and periaqueductal gray (Wagner et al., 2007). Short pulses of gaseous CO₂ applied to the nasal mucosa evoked pain that was dose-dependently decreased by alfentanil. More interestingly, this study applied functional magnetic resonance imaging to investigate the opioid effects and found this assessment method sufficiently sensitive to see differential effects on the affective and sensory components of the pain (Oertel et al., 2008). Furthermore, this study, as one of few, was able to demonstrate how carriers of different genetic variants of the μ -opioid receptor responded differently to alfentanil. Alfentanil has also provided robust analgesia in electrically evoked pain in the teeth (Chapman et al., 1990).

ii. Skin hyperalgesia. Alfentanil has been tested in a model that evokes hyperalgesia by intradermal injection of capsaicin (Eisenach et al., 1997; Sethna et al., 1998; Wallace et al., 2002a,b). Three of four studies found effect on the evoked pain, hyperalgesia and allodynia (Eisenach et al., 1997; Wallace et al., 2002a,b). Remifentanil has also been tested in the capsaicin model, where two studies demonstrated that the area of secondary hyperalgesia obtained with heat/capsaicin stimulation

was reduced for both pinprick and brush (Petersen et al., 2001, 2003; Hood et al., 2003). Furthermore, alfentanil has been tested against electrically evoked secondary hyperalgesia and in this model, pain intensity as well as hyperalgesia and allodynia was reduced (Koppert et al., 2001; Schulte et al., 2005; Wehrfritz et al., 2010). Four studies tested remifentanil in the above model, showing a reduction in ongoing pain and hyperalgesia (Koppert et al., 2003a,b; Tröster et al., 2006; Singler et al., 2007). In the burn injury model, alfentanil reduced secondary hyperalgesia to pinprick, further suggesting a central effect of this opioid (Schulte et al., 2005). Finally, Lötsch and Angst (2003) found effect of remifentanil on hyperalgesia in response to mechanical (brush, punctated, and blunt) and electrical stimulation before and after induction of hyperalgesia with a freeze lesion.

iii. Muscle. Alfentanil is well characterized in experimental muscular pain such as deep pressure, intramuscular electrical stimulation, intramuscular injection of hypertonic saline, and ischemic pain. Black et al. (1999) found that alfentanil reduced pain intensity (Luginbühl et al., 2001). In contrast, remifentanil induced hyperalgesia to pressure pain (Luginbühl et al., 2003). Alfentanil showed analgesic effect in tests involving pressure and injection of hypertonic saline (Luginbühl et al., 2001; Schulte et al., 2003, 2006; Angst et al., 2004; Olofsen et al., 2005). Two studies investigated and found effect of remifentanil to single and repeated electrical stimulation of the muscle (Curatolo et al., 2000b; Luginbühl et al., 2003). The tourniquet model (mainly evoking muscle ischemia), was not sensitive to alfentanil (Luginbühl et al., 2001). Furthermore, the effect of remifentanil against pain from pressure applied to the tibia has been tested and evaluated by fMRI, where the drug decreased the pain-induced regional increase in the cerebral blood flow (Lorenz et al., 2003).

iv. Models that induce endogenous pain modulation. The cold pressor test was sensitive to the effects of alfentanil (Luginbühl et al., 2001).

v. Conclusions. Alfentanil is a very potent opioid showing convincing analgesia in experimental pain over a broad dose range. However, in the study by Schulte et al. (2006), a dose-response relationship was seen, and the pain parameters were mainly affected at the high dose. Seven of the 11 studies with remifentanil were comparable in dosing (Gustorff et al., 2001; Petersen et al., 2001, 2003; Lorenz et al., 2003; Tröster et al., 2006; Singler et al., 2007; Wagner et al., 2007). The studies generally showed robust analgesia in both acute and hyperalgesic pain models and drug doses throughout the therapeutic interval seems to work in experimental pain models.

The traditional opinion that opioids attenuate mainly C-fiber-mediated pain is not always correct; two studies could not detect analgesia from alfentanil toward heat pain and one was not sensitive to cold pain (Luginbühl et al., 2001; Wallace et al., 2002b). This is not explained by

an insufficient dose, because heat pain was affected by alfentanil in a study using a lower dose than in the study by Luginbühl et al. (2001) (Angst et al., 2004). In general, it would be expected that a μ -opioid agonist would affect pain conveyed through C fibers, and heat pain is traditionally believed to be conveyed through these fibers (Hallin et al., 1982; Tian et al., 2005). However, nociception to a fast increase in temperature, which is associated with A δ fiber stimulation, can be less sensitive to opioids; hence, it could be argued that the increase in temperature (1.5–2°C/s) was too fast in the nonsensitive studies (Le Bars et al., 2001; Luginbühl et al., 2001; Wallace et al., 2002b). On the other hand, another study using argon laser stimulation showed analgesia to alfentanil although the heating rate was higher (Petersen-Felix et al., 1996; Luginbühl et al., 2001; Wallace et al., 2002b). However, the heating rate for laser stimulation is measured in Joules and cannot readily be converted into °C per second, making a direct comparison difficult.

The capsaicin model evokes intense and tonic pain; it could therefore be expected that opioid analgesia can be shown in this model. However, conflicting findings exist and one study found no effects of alfentanil on the capsaicin model, which could be related to the problematic repeatability of the evoked secondary hyperalgesia (Sethna et al., 1998). In theory, an analgesic can inhibit secondary hyperalgesia by lowering the nociceptive barrage from the periphery to the spinal synapse. Furthermore, hyperalgesia can be prevented by inhibition of several central mechanisms such as wind-up (Dickenson, 1995). Because alfentanil decreased the immediate pain response to capsaicin, the incoming nociceptive barrage is probably lowered. However, it is difficult to conclude whether the peripheral effect is the cause for the subsequent decrease in the secondary hyperalgesic area or if alfentanil, by a direct spinal/supraspinal mechanism, prevents the development of hyperalgesia. The model by Koppert et al. (2001) in which hyperalgesia is evoked from continuous intradermal electrical stimulation illustrates how alfentanil affects both peripheral and central pain mechanisms.

Carriers of different genetic variants of the μ -opioid receptor responded differently to alfentanil (Oertel et al., 2008). This indicates that factors other than dose and experimental setup can influence the outcome in human experimental pain studies.

2. Longer Acting Opioids.

a. Traditional μ -receptor agonists. Morphine is a widely used analgesic, and it has been tested extensively in experimental pain. Fewer investigations have been performed for fentanyl and oxycodone. Fentanyl is actually a short-acting opioid, but in the reviewed studies, it was applied via transdermal depot formulation, producing effects more comparable with the long-lasting opioids. Both morphine and oxycodone are μ -receptor agonists. Animal studies have indicated that oxycodone has

a more pronounced effect at the κ -receptor compared with morphine (Ross and Smith, 1997). However, this has been debated (Kalso, 2005, 2007), and in this review, oxycodone is described with morphine because these two opioids have been compared in some experimental pain studies in healthy volunteers.

i. Skin and teeth. Both morphine and oxycodone have been tested against cutaneous heat and cold pain, mechanical (pinching) pain, and electrical pain, and generally these models reflect analgesia from these opioids (Naef et al., 2003; Schulte et al., 2003; Joly et al., 2005; Staahl et al., 2006a; Arendt-Nielsen et al., 2009; Olesen et al., 2010a; Samer et al., 2010). Three studies found sensitivity of electrical pain for morphine, whereas another did not (Schulte et al., 2003; Joly et al., 2005; Staahl et al., 2006a). Two studies showed effect of morphine on the warmth detection threshold and pain detection threshold in response to heat, pressure and electrical stimulation (Arendt-Nielsen et al., 1991a,b; Joly et al., 2005). EEG recordings have been used to assess electrically induced pain in the teeth and skin. This type of pain assessment showed opioid analgesia in accordance with the psychophysical pain scoring (Chapman et al., 1990; Quante et al., 2004). Fentanyl has been tested against electrical and thermal (heat and cold) skin pain. Electrical pain was unaffected by fentanyl in two studies, whereas two studies found effect on this pain modality (Ginosar et al., 2003; Tucker et al., 2005; Koltzenburg et al., 2006; Andresen et al., 2010). Effects on heat pain have been tested through various stimulation paradigms and conflicting results exist. Figure 10 gives an example of the analgesic effect of transdermal fentanyl on heat pain (Fig. 10). Three studies found that fentanyl attenuated this parameter, which was contra-

dictory to the finding of Tucker et al. (Tucker et al., 2005; Koltzenburg et al., 2006; Andresen et al., 2010). Repetitive heat pain was unaffected by fentanyl, whereas repetitive cold pain was attenuated by fentanyl (Ilkjaer et al., 1996; Price et al., 2002). Electrical dental pain has been tested and found to be attenuated by fentanyl (Chapman et al., 1990; Hill et al., 1990).

ii. Skin hyperalgesia. Morphine has been tested in various models involving hyperalgesia, such as burn injuries, freeze lesions, continuous electrical stimulation, and radiation with ultraviolet light (Møiniche et al., 1993; Warncke et al., 1997; Koppert et al., 1999; Tegeder et al., 2003; Schulte et al., 2004). Hyperalgesia and allodynia from burn injuries were unaffected in two studies (Warncke et al., 1997; Schulte et al., 2005). However, when Schulte et al. (2005) applied a higher dose of morphine (0.2 mg/kg for 15 min and 0.66 mg/kg for 110 min), reduction of the area of secondary hyperalgesia was seen as the only modulation. However, peripheral effects of morphine were detected by the burn injury model in the study by Møiniche et al. (1993). Koppert et al. (1999) investigated the peripheral effects of morphine (applied as intravenous regional anesthesia) in the UVB-induced hyperalgesia model and found that morphine attenuated primary hyperalgesia to heat pain. Fentanyl has been tested once in the above model and showed no effect here, where the UVB model was also applied but was not sensitive to fentanyl (Andresen et al., 2010).

iii. Muscle and bone pain. Morphine has been tested against pain from deep pressure algometry, electrical stimulation, injection of hypertonic saline, and ischemic pain (Plesan et al., 2000; Schulte et al., 2003; Pud et al., 2006; Staahl et al., 2006a). Ischemic pain and pain in

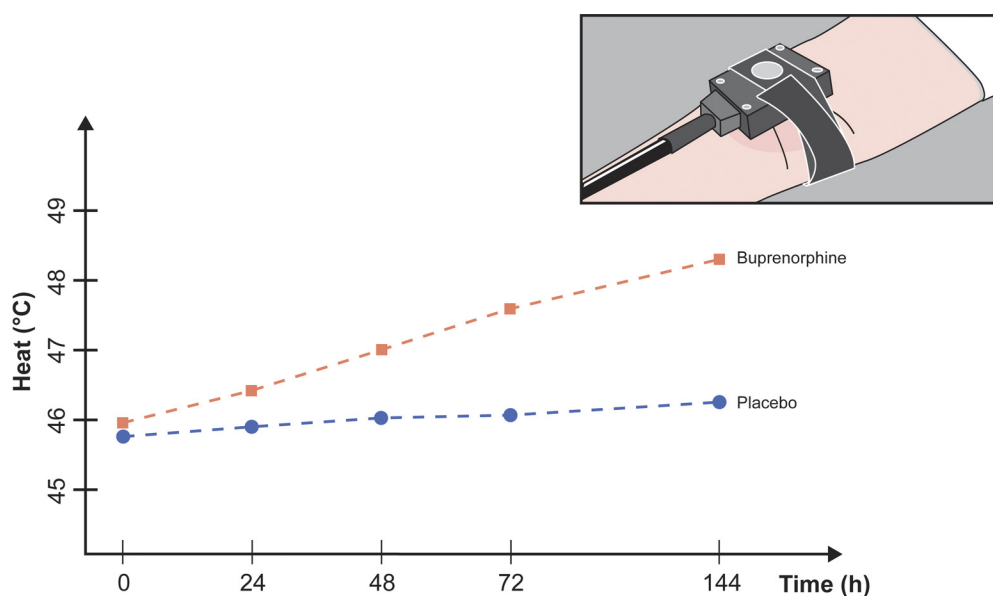

FIG. 10. Buprenorphine effect on skin heat pain. Graph showing an example of analgesic effect of buprenorphine to experimental induced heat pain in the skin using a thermode (top right). Measurement of heat tolerance threshold (degrees Celsius) was assessed before treatment and 24, 48, 72, and 144 h after treatment with buprenorphine (orange) and with placebo (blue). Tolerance threshold increased over time after treatment with buprenorphine compared with placebo.

response to electrical stimulations was decreased by morphine (Smith et al., 1966; Segerdahl et al., 1994; Plesan et al., 2000; Pud et al., 2006). Pain in response to hypertonic saline was sensitive to modulation from morphine when a high dose was administered (Schulte et al., 2003, 2006). Oxycodone has been tested against pain from deep pressure algometry and electrical stimulation, where it was effective (Staahl et al., 2006a). Furthermore, both drugs were applied in the cuff-pressure model, in which it was found that the opioids had similar effect for pain at the pain detection threshold, but for pain tolerance threshold, oxycodone was more effective than morphine (Fig. 11) (Arendt-Nielsen et al., 2009; Olesen et al., 2010a). In a model of bone pain, pressure pain from the tibial bone was unaffected by fentanyl (Andresen et al., 2010).

iv. Muscle hyperalgesia. Hyperalgesia produced by eccentric muscle contraction was decreased by morphine (Smith et al., 1966; Segerdahl et al., 1994). In contrast, hyperalgesia after intramuscular injection of nerve growth factor was unaffected by fentanyl (Andresen et al., 2010).

v. Viscera. Morphine and oxycodone were both effective against mechanical and electrical esophageal pain, but only oxycodone attenuated thermal esophageal pain (Staahl et al., 2006a; Arendt-Nielsen et al., 2009).

vi. Visceral hyperalgesia. Oxycodone and morphine have been tested in esophageal hyperalgesia induced by a combination of acid and capsaicin. Here, only oxycodone showed effect, and only on the parameters of pain detection threshold in response to electrical stimulation and referred pain area to heat (Olesen et al., 2010a). Figure 12 illustrates the multimodal esophageal probe and the effect of oxycodone and morphine on electrical esophageal stimulation (Fig. 11).

vii. Models that induce endogenous pain modulation. Different opioids have been applied in studies

using the cold pressor test and have been found to be effective. The model was even sensitive enough to separate the effects of different genotypes in the subjects (Eckhardt et al., 2000; Grach et al., 2004; Zwisler et al., 2009, 2010; Samer et al., 2010). Fentanyl has been tested in the cold pressor test, and this model was sensitive to the analgesia induced. The analgesic effect was shown more robustly when assessed as the area under the VAS curve compared with the peak pain intensity and the mean pain intensity (Koltzenburg et al., 2006).

viii. Conclusions. In the study by Roberts et al. (2006), it would be expected that the applied heat pain would be sensitive to morphine. The lack of effect could be explained by the low dose used in this study, which was designed to determine the synergistic effect for morphine in combination with tetrahydrocannabinol (0.0.2 mg/kg i.v.). Schulte et al., 2003, 2006 did a dose-response study of morphine against pain in response to injection of hypertonic saline and found that a dose above 0.14 mg/kg i.v. was necessary to show effect in this model. However, other studies that used other pain models applied doses under 0.14 mg/kg i.v. and found an effect of morphine, illustrating how the pain models differ in sensitivity to a given dose (Price et al., 1985; Plesan et al., 2000; Tegeder et al., 2003). Accordingly, the study by Brennum et al. (1993) had a good sensitivity of almost all sensory tests toward morphine. Here, 4 mg of morphine was administered in the epidural space; this dose is in the upper end of the therapeutic range (Joly et al., 2005). In the study by Staahl et al. (2006a), analgesia was seen for both oxycodone and morphine for several pain parameters in various tissues, and this group also applied doses in the therapeutic range.

As stated previously, opioids mainly attenuate pain intensities above the pain detection threshold (Poulsen et al., 1995; Enggaard et al., 2001). However, two studies showed effect of morphine on the warmth detection threshold and pain detection thresholds in response to heat, pressure, and electrical stimulation (Arendt-Nielsen et al., 1991a,b; Joly et al., 2005). Warmth sensations are conveyed by C fibers; hence, there is a neurophysiologic explanation for morphine modulating the sensation of warmth (Le Bars et al., 2001). Because morphine mainly affects dorsal horn activity produced from tonic C-fiber activation, it is most likely that morphine will produce significant effect on a pain tolerance threshold evoked by a tonic type of pain (van der Burght et al., 1994; Fillingim et al., 2005b; Staahl et al., 2006a). However, exceptions exist, and the study by Roberts et al. (2006) found no effect of morphine on 5-s stimulation at 51°C, stimulus intensity normally considered well above the pain detection threshold. For heat pain to be sensitive to opioid modulation, it has been argued that it needs to be applied with slow temperature rises (<1°C/s) (Le Bars et al., 1976; van der Burght et al., 1994). On the other hand, morphine has also shown an effect on pain from rapid increases in temperature (Arendt-Nielsen et

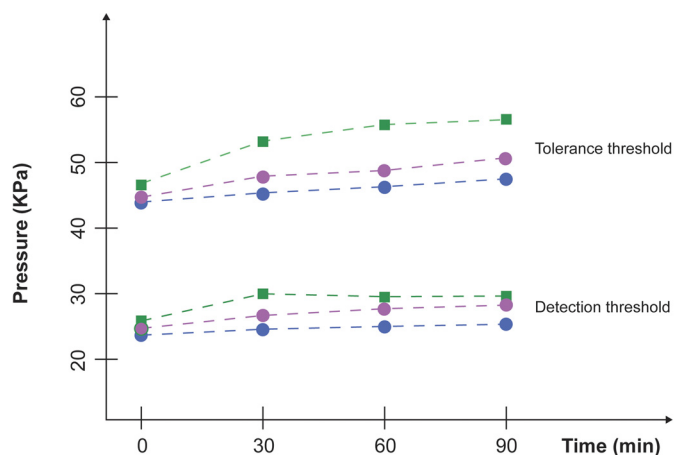

FIG. 11. Oxycodone and morphine effects on muscle pain. Analgesic effects of morphine (purple), oxycodone (green), and placebo (blue) on cuff pressure algometry in the thigh are shown for 24 healthy volunteers. Bottom, pain detection thresholds; top, pain tolerance thresholds. Analgesic effect was more pronounced when the higher intensity thresholds were evaluated.

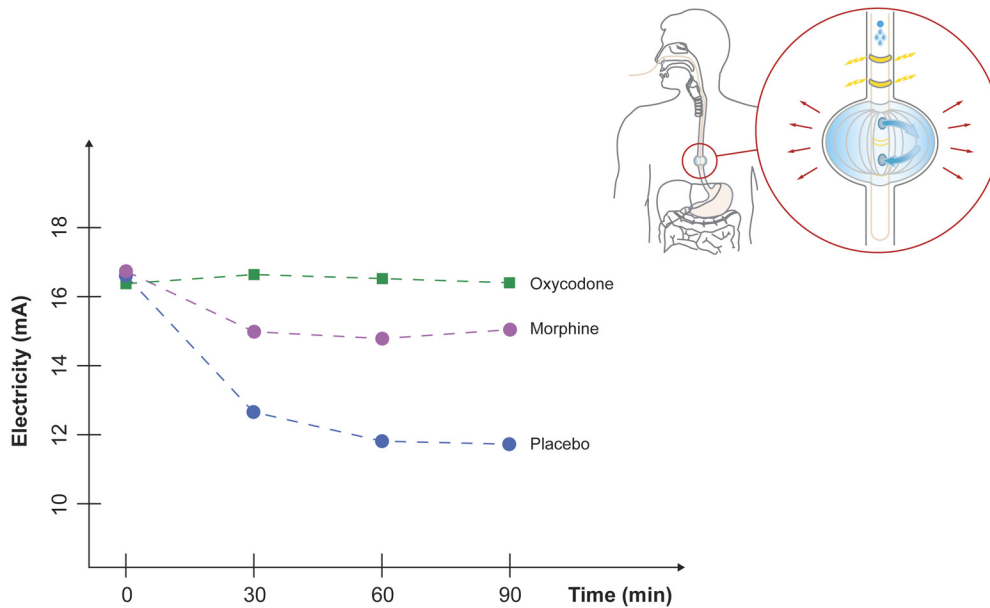

FIG. 12. Oxycodone and morphine effects on visceral pain. Analgesic effects of morphine (purple), oxycodone (green), and placebo (blue) are shown for 24 healthy volunteers. Pain detection thresholds for electrical stimulation in the esophagus are shown. Visceral hyperalgesia was induced after baseline stimulation by perfusion of the esophagus with a combination of acid and capsaicin. Therefore, less intensity was tolerated over time after treatment with placebo. The hyperalgesia was prevented by oxycodone and reduced after morphine treatment.

al., 1991b; van der Burght et al., 1994; Naef et al., 2003; Joly et al., 2005).

Compared with models in which the painful stimulus is applied to the skin, morphine analgesia seems to be more robust in deep pain. The reason for this could be that deep pain is often considered more unpleasant than skin pain, and the muscular models often apply a more tonic type of pain (hypertonic saline, cold pressor test, etc.). The unpleasantness of pain is associated with the limbic structures in the brain, an area in which opioids traditionally are known to modulate the pain response (Apkarian et al., 2005; Sprenger et al., 2006). Morphine and oxycodone show different effects in visceral pain (Stahl et al., 2006a; Olesen et al., 2010). These studies revealed important tissue differences in opioid analgesia, particularly when comparing somatic and visceral pain. This reflects the clinical situation in which visceral pain in contrast to somatic pain can be difficult to treat with traditional μ -opioid agonists, and in a few clinical studies, oxycodone has been found more effective than morphine (De Schepper et al., 2004; Lenz et al., 2009). Morphine and oxycodone are generally effective toward pain from many different stimulus modalities (Chapman et al., 1990; Naef et al., 2003; Tegeder et al., 2003; Schulte et al., 2004; Joly et al., 2005). However, the results are not as clear-cut as seen with alfentanil, and this could be caused by the complex pharmacokinetic profile of morphine. The amount of morphine absorbed is very individual, and this opioid enters the main effect site (the CNS) by crossing the blood-brain barrier slowly (D'Honneur et al., 1994). All this causes increased variability of the individual subject's response to morphine, blurring the findings in experimental pain research (Chapman et al., 1990; Löttsch, 2005).

b. Opioids with weak affinity for the μ -opioid receptor. Codeine is an analgesic with weak affinity for the μ -opioid receptor and has been tested in experimental pain studies in healthy volunteers.

i. Skin. Codeine worked against acute experimental pain in response to heat, pressure, and single/repeated electrical stimulation (Stacher et al., 1982; Poulsen et al., 1996b; Walker and Zacny, 1998; Arendt-Nielsen et al., 2000a,b; Enggaard et al., 2001).

ii. Models that induce endogenous pain modulation. Codeine has shown effect on the cold pressor test (Poulsen et al., 1996b; Arendt-Nielsen et al., 2000b).

iii. Conclusions. Codeine has been applied in supratherapeutic doses in all studies, and this could be the explanation for the effects. However, the application of supratherapeutic doses has probably given a significant plasma concentration of morphine/morphine-6-glucuronide, and this could explain the convincing effect seen in the more phasic pain models that traditionally are thought to be less sensitive to opioid analgesia. On the other hand, two studies applied both the cold pressor test and more phasic pain tests, such as heat, electrical, and pressure pain. These studies did only find effect in the more tonic pain from the cold pressor test (Poulsen et al., 1996b; Arendt-Nielsen et al., 2000b).

Codeine is a weak opioid that is metabolized in the liver to morphine and the main effect of codeine is thought to be mediated via μ -receptors, mainly through the main metabolites, morphine and morphine-6 glucuronide (Guay et al., 1987; Srinivasan et al., 1997). Seven percent of white people lack the ability to metabolize codeine, whereas 25% of Ethiopians are ultrarapid metabolizers because of a polymorphism of the enzyme responsible for this metabolism (P4502D6) (Poulsen et

al., 1996b). This is reflected in experimental pain models, where subjects who are slow metabolizers do not have any analgesic effect of codeine (Poulsen et al., 1996b), and it enriched enrollment (excluding slow metabolizers) could be considered when codeine effects are assessed.

c. κ -Receptor agonists. Pentazocine is a κ -opioid agonist and has been subject for large interest regarding gender differences, because this has been found in clinical studies (Gear et al., 1996).

i. Skin and nasal mucosa. Heat and electrical stimulation produces pain that is sensitive to pentazocine analgesia (Stacher et al., 1982, 1983; Bromm et al., 1986a; Ribeiro-Dasilva et al., 2011). Event-related potentials and pain ratings to different gaseous stimulation of the nasal mucous were also responsive to pentazocine analgesia (Kobal, 1985; Bromm et al., 1986a; Kobal et al., 1990).

ii. Muscle. Pressure pain and ischemic pain are both sensitive to analgesia from pentazocine (Fillingim et al., 2004, 2005a; Ribeiro-Dasilva et al., 2011).

iii. Conclusions. Pantazocine worked well in several types of experimental pain models but gender differences were generally not confirmed in studies involving experimental pain models (Fillingim et al., 2004, 2005a).

3. Opioids with Mixed Binding Profile.

a. Tramadol.

i. Skin and nasal mucosa. Tramadol has shown effect in experimental pain from pressure stimulation, electrical stimulation of the sural nerve (nociceptive reflex), and the cold pressor test (Poulsen et al., 1996a; Enggaard et al., 2006). Phasic pain from stimulating the nasal mucosa by gaseous carbon dioxide was attenuated by tramadol (Hummel et al., 1994; Thürauf et al., 1996). Here, the pain was assessed by subjective pain ratings but also by electrophysiological assessment of pain using evoked brain potentials. In the study by Thürauf et al. (1996), an effect was found only on evoked brain potentials and not on pain ratings (Thürauf et al., 1996). Furthermore, tonic pain from stimulating the nasal mucosa with dry air is sensitive to tramadol (Thürauf et al., 1996; Joly et al., 2005). Pain from electrical stimulation of the tooth pulp was also sensitive to tramadol, but mainly with doses above 50 mg (Rohdewald et al., 1988; Närhi et al., 1992; Högger and Rohdewald, 1999).

ii. Skin hyperalgesia. Tramadol has been tested against continuous electrically evoked secondary hyperalgesia and in this model, the on-going pain intensity was reduced, but the hyperalgesia and allodynia was not affected significantly (Filitz et al., 2008). Tramadol significantly reduced menthol-evoked cold hyperalgesia (Altis et al., 2009).

iii. Muscle. Ischemic pain was unaffected by tramadol (Loram et al., 2005).

iv. Muscle hyperalgesia. The delayed-onset muscle soreness was unaffected by tramadol in the study by Loram et al. (2005) (see conclusions below).

v. Models that induce endogenous pain modulation. A study investigating the influence of the pharmacokinetics on the analgesic effect of tramadol in the cold pressor test found that the model reflected analgesia also in the presence of an inhibitor of the enzyme (P4502D6) (Noehr-Jensen et al., 2009).

vi. Conclusions. Hummel et al. (1994) used doses above the therapeutic range (150 mg) of tramadol, and this could be a cofactor explaining the robust effect seen in this study. Ischemic pain and delayed onset muscle soreness was unaffected in a study engaging a therapeutic-like dosing regime, and the use of doses in the lower end of the therapeutic range in the study by Loram et al. (2005) may explain the lack of analgesia in this otherwise well designed study, mimicking the clinical situation with multiple dosing. Likewise, tramadol mainly affected pain from electrical tooth pulp stimulation when doses in the range of 100 mg were applied (Rohdewald et al., 1988; Högger and Rohdewald, 1999). These findings indicate that doses above or in the upper end of the therapeutic range are necessary to show an effect under experimental conditions. When a drug with an active metabolite is being tested, it can also be crucial to locate poor/extensive metabolizers, because such individuals can add increased variation and decrease the statistical power of the trial (Poulsen et al., 1996a).

Besides effects in the opioid system tramadol exerts analgesia through actions in the noradrenergic and serotonergic systems (Minami et al., 2007). Tramadol exerts its opioid action through a metabolite (*O*-desmethyltramadol), which has an affinity for the μ -opioid receptor approximately 10 times lower than that of morphine (Gillen et al., 2000). As for codeine polymorphism of the enzyme (P4502D6), responsible for this metabolism exists in a significant proportion of the population (Poulsen et al., 1996a). This genetic factor is reflected in the findings in experimental pain studies, where only extensive metabolizers exhibit convincing analgesia in experimental pain from pressure stimulation, electrical stimulation of the sural nerve (nociceptive reflex), and the cold pressor test (Poulsen et al., 1996a; Enggaard et al., 2006). However, a weak inhibition of the enzyme did not influence analgesia (Noehr-Jensen et al., 2009).

C. Other Types of Analgesics

1. Cannabinoids

a. Δ^9 -Tetrahydrocannabinol.

i. Skin. Δ^9 -Tetrahydrocannabinol has been tested in models involving sensation to warmth/heat and cold as well as pain evoked by mechanical [pinprick (von Frey) and brush] and electrical stimulation (Naef et al., 2003, 2004; Roberts et al., 2006; Wallace et al., 2007). The majority of the studies found no effect on the pain parameters except for brush- and pinprick-evoked pain (Wallace et al., 2007). However, in an older study applying electrical skin pain and repeated pressure algometry, the pain detection thresholds, but not the pain tol-

erance thresholds, to these pain stimulations were increased after administration of Δ^9 -tetrahydrocannabinol.

ii. Skin hyperalgesia. After intradermal injection of capsaicin, there was no effect of smoking cannabis on secondary hyperalgesia in response to heat or pinprick or in response to allodynia from stroking (Wallace et al., 2007).

iii. Models that induce endogenous pain modulation. The cold pressor test has been used with different routes of administration of the drug, where no effect was found after either oral, intravenous, or pulmonary administration (Naef et al., 2003; Naef et al., 2004).

iv. Conclusions. Because this drug has not been approved for pain treatment, no therapeutic range for clinical use exists. However, a dose range of 5 to 10 mg p.o. has been found to be effective in sclerosis (Svendsen et al., 2004). On the other hand, even doses of 20 mg p.o. did not produce significant analgesia in acute experimental pain (Naef et al., 2003). The only model in which Δ^9 -tetrahydrocannabinol produced significant analgesia (spontaneous pain from intradermal capsaicin) administered the drug via smoking of cannabis. This exposed the subjects to a mixture of cannabinoids, several of which possess activity in the central nervous system (Wallace et al., 2007). This makes it difficult to compare the dose of this study with those in other studies using the clean compound. Furthermore one study found an inverse dose-response relation for Δ^9 -tetrahydrocannabinol (Wallace et al., 2007).

The analgesic effect of Δ^9 -tetrahydrocannabinol is difficult to show in acute experimental pain models. However, the drug has shown a complex pattern of analgesia, with a stronger effect on pain intensities below the pain detection threshold than those above (Raft et al., 1977). This pattern is opposite that of classic analgesics such as opioids and could reflect that Δ^9 -tetrahydrocannabinol works on the sensory-discriminative rather than affective-motivational aspects of pain, which is in consensus with the findings of Raft et al. (1977) and Wallace et al. (2007). The limited effect of this compound reflects the fact that the evidence of clinical effect of cannabinoids is limited to sclerosis and painful spasticity (Karst et al., 2010).

IX. Analgesic Assessment by Experimental Human Pain Models in Patients

It has been suggested that patients with chronic pain may have an enhanced sensitivity to analgesics. This can be exemplified by the increased sensitivity to exogenous and endogenous opioids (Price et al., 2002). The enhanced sensitivity could result from several possible factors, including increased sensitivity or density of opioid receptors or enhancement of factors that contribute to placebo analgesia. For example, it is possible that patients experience enhanced desire for pain reduction, greater expectations of pain reduction, and consequently

an increased placebo contribution to effects of analgesics. Another explanation could be that, for example, opioid antinociceptive effects are more pronounced in inflamed tissue. It has been shown that after induction of peripheral inflammation, the axonal transport of opioid receptors in fibers of the sciatic nerve is greatly enhanced. Subsequently, the density of opioid receptors on cutaneous nerve fibers in the inflamed tissue increases (Walker, 2003). Furthermore, animal studies have shown that in the inflammatory state opioid agonists have easier access to neuronal opioid receptors, because 1) inflammation entails a disruption of the perineurium (a normally rather impermeable barrier sheath encasing peripheral nerve fibers) and 2) the number of peripheral sensory nerve terminals is increased in inflamed tissue (sprouting) (Obara et al., 2009). Therefore, testing the effect of analgesics by experimental pain in patients can provide further insight into analgesic mechanisms in the up-regulated pain system. This section addresses how the efficacy of analgesics has been assessed in different patient groups using experimental pain models. Conclusions on dosing regimens or mechanistic aspects are included in each subsection. Because fewer studies have been performed in patients compared with healthy volunteers, most studies performed in patients are included.

A. Nonopioids

1. Nonsteroidal Anti-Inflammatory Drugs and Acetaminophen. Diclofenac, ibuprofen, and naproxen are NSAIDs that have all been tested in experimental pain in patients (Table 1). Acetaminophen has been tested in only a single study in patients.

a. Acetaminophen. Acetaminophen was investigated in patients whose main complaint was moderate to severe dental pain. The change in pain threshold was measured by electric pulp testing. Acetaminophen increased the pain threshold in response to electrical stimulation (Carnes et al., 1998).

b. Diclofenac, ibuprofen, and naproxen. Diclofenac was tested on postoperative pain after caesarean delivery. Electrical sensory thresholds significantly increased after surgery when diclofenac was given in combination with tramadol. Diclofenac showed no analgesic effect on its own (Wilder-Smith et al., 2003a). Ibuprofen cream was tested in patients with arthritis using an electronic pressure algometer on the affected joints. Ibuprofen caused a significant increase in pressure pain tolerance threshold but not in pressure pain threshold (Arendt-Nielsen et al., 1994). Naproxen was tested in patients whose chief complaint was moderate to severe dental pain. The change in pain threshold was measured by electric pulp testing. No elevation of pain threshold was seen (Carnes et al., 1998).

c. Conclusions. The administered dose of diclofenac (75 mg) was lower than the normal therapeutic dose for weak pain (200–400 mg, three to four times daily),

TABLE 1
NSAIDs and acetaminophen

Drug and Dose	Method	Comment	References
Acetaminophen 1 g oral	Electrical pulp testing in 20 patients with dental pain.	Pain threshold increased.	Carnes et al. (1998)
Diclofenac 75 mg oral	Electrical stimulation at or distant from the incision were studied in 120 patients who had elective cesarean deliver.	No significant effect of NSAID alone, but increases in sensation and pain tolerance thresholds were seen for the combination tramadol plus diclofenac.	Wilder-Smith et al. (2003)
Ibuprofen Dolgit cream (5%), 3 g 3× daily	Pressure stimulation of finger joints in 11 patients with rheumatoid arthritis.	Pain detection threshold did not increase but a significant difference in pressure pain tolerance threshold was found.	Arendt-Nielsen et al. (1994)
Naproxen sodium 220 mg oral	Electrical pulp testing in 20 patients with dental pain.	No significant effect.	Carnes et al. (1998)

which could explain the reason why no clinical effect was observed. Furthermore, there is need to perform more studies before a conclusion can be drawn.

Even though an effect of acetaminophen was demonstrated in experimental testing in patients with dental pain, the authors concluded that this difference was probably not clinically meaningful (Carnes et al., 1998). Therefore, at usual doses, NSAIDs and acetaminophen are not particularly effective at changing the threshold in response to sharp pain in experimental pain studies (Carnes et al., 1998). Only ibuprofen was tested in patients with chronic pain who had rheumatoid arthritis. Dermal application caused a significant increase in pressure pain tolerance, whereas pain detection threshold was not affected, likely reflecting that more intense pain is needed to show an effect in this model (Arendt-Nielsen et al., 1994).

2. *N*-Methyl-D-aspartate Antagonists. Both dextromethorphan and ketamine are NMDA antagonists that have been studied in experimental pain in patients (Table 2).

a. Dextromethorphan. Dextromethorphan is a weak NMDA antagonist (Siu and Drachtman, 2007). It has been tested in two studies (Ilkjaer et al., 2000; Staud et al., 2005). In patients with elective abdominal hysterectomy, pressure pain detection threshold was determined 2 cm caudal to the middle of the surgical incision with a handheld electronic pressure algometer. Pain detection thresholds were assessed by applying von Frey hairs of increasing diameter to the skin 5 cm from the surgical incision, but dextromethorphan had no effect on this model (Ilkjaer et al., 2000). In patients with fibromyalgia, temporal summation to thermal skin pain and mechanical muscle pain was evoked in both hands. Dextromethorphan showed effect on both thermal and mechanical summation elicited by train pulses in a dose-dependent manner (Staud et al., 2005).

b. Ketamine. Ketamine is a NMDA antagonist that has been widely studied in experimental pain in patients. Seven studies investigated the effect of ketamine on skin pain (Eide et al., 1995; Wilder-Smith et al., 1998; Leung et al., 2001; Jørum et al., 2003; Gottrup et al.,

2006; Ayesh et al., 2008), whereas one study tested the effect on muscle pain (Graven-Nielsen et al., 2000). In patients with temporomandibular joint arthralgia, von Frey filaments were used for assessment of pinprick and tactile (touch) sensations around the temporomandibular joint. Presence or absence of allodynia or hypoesthesia to light mechanical brush of the skin was also assessed. A pressure algometer was used to test the sensitivity to deep stimuli of the joint. No effect of ketamine was found on any of those measures (Ayesh et al., 2008). Eide et al. (1994) examined patients with postherpetic neuralgia in two studies. In the first study, allodynia was assessed using an electric toothbrush on the affected skin area. Pain in response to temporal summation with pinprick was evoked by von Frey filaments. Threshold temperatures for sensations of warm, cold, and heat pain were determined in cervical, thoracic, lumbar, and facial regions. Ketamine showed an effect only against allodynia and temporal summation. The second study by Eide et al. (1995) was a dose-response study using continuous (subcutaneous) infusion of ketamine in five patients who previously reported pain relief after ketamine using a comparable methodology. Allodynia was markedly reduced after the start of ketamine infusion, and after 1 week of infusion at the rate of $0.05 \text{ mg} \cdot \text{kg}^{-1} \cdot \text{h}^{-1}$, allodynia was reduced 59 to 100%. The reduction of allodynia was more pronounced in only one patient after 1 week of infusion at the higher rate of $0.75 \text{ mg} \cdot \text{kg}^{-1} \cdot \text{h}^{-1}$. In the other patients, there was no further reduction of allodynia with increasing infusion rates. Pain in response to temporal summation was also reduced by infusion of ketamine with increasing effect of higher infusion rates (Eide et al., 1995). In patients suffering from chronic complex regional pain syndrome type 1, the effect of ketamine on experimental heat pain was investigated. Seven intravenous 5-min low-dose *S*(+)-ketamine infusions with increasing doses at 20-min intervals were applied. The skin on the volar side of the forearm was stimulated by heat. Ketamine had a dose-dependent antinociceptive effect (Sigtermans et al., 2010).

TABLE 2
NMDA antagonists

Drug and Dose	Method	Comment	References
Dextromethorphan 150 mg oral	Pressure stimulation and von Frey hair stimulation to the skin near surgical incision in 50 patients scheduled for elective abdominal hysterectomy.	No significant effects.	Ilkjaer et al. (2000)
60 or 90 mg oral	Repeated stimulation by thermal pulses applied to the skin or by mechanical stimuli to the muscle in 14 patients with fibromyalgia.	Thermal and mechanical repeated stimulations were reduced by both doses, 90 mg being most effective.	Staud et al. (2005)
Ketamine 30-min (0.3 mg/kg i.v.)	Pressure, intramuscular, and cutaneous electrical stimulation. The pain intensity during experimental muscle pain by intramuscular hypertonic saline was also recorded in 17 patients with whiplash-associated disorder.	No significant effects in any of the tests.	Lemming et al. (2005)
0.3 mg/kg i.v.	Pressure pain stimulation at tender points and control points in 11 patients with fibromyalgia.	Pressure pain thresholds and pain tolerances at tender points and control points increased.	Sørensen et al. (1995)
0.3 mg/kg i.v.	Pressure pain stimulation at tender and nontender point areas in 18 patients with fibromyalgia.	Patients were classified as responders or nonresponders according to clinical pain intensity ratings taken before, during, and after the tests. Pressure pain and tolerance thresholds increased significantly in responders but not in nonresponders	Sørensen et al. (1997)
Seven 5-min low-dose i.v. infusions with increasing doses at 20-min intervals	Skin heat pain stimulation in 10 patients suffering from chronic complex regional pain syndrome type 1.	A dose-dependent anti-nociceptive effect to skin heat stimuli was observed. This effect ended immediately after termination of the infusion.	Sigtermans et al. (2010)
0.55 mg i.v.	Tactile, pinprick, and pressure pain stimulation at 11 sites around the temporomandibular joint in 18 patients with temporomandibular joint arthralgia.	No significant effects in any of the tests.	Ayesh et al. (2008)
0.15 mg/kg i.v.	Brush (allodynia), repeatedly pricking the affected skin area, tactile, and thermal stimulations of the skin were examined in eight patients with postherpetic neuralgia.	No significant changes in thermal pain thresholds or tactile sensations were observed. Allodynia and pain evoked by repeatedly pricking the affected skin area were significantly decreased.	Eide et al. (1994)
0.24 mg/kg as 30 min infusion	Brush and repetitive pinprick stimuli of the skin, and stimulation by acetone drop on the allodynic skin in 20 patients with nerve injury pain.	Evoked pain to brush and repetitive pinprick was reduced. Acetone-induced cold allodynia was unchanged.	Gottrup et al. (2006)
0.3 mg/kg over 30 min	Intramuscular infusion of hypertonic saline into the anterior tibial muscle as well as intramuscular electrical stimulation (single and repeated), muscle pressure, and cutaneous electrical stimulations were performed in 15 patients with fibromyalgia.	Pain from hypertonic saline was reduced. Local and referred pain areas were reduced. No differences in response to single electrical stimulation but temporal summation to intramuscular and cutaneous electrical stimuli decreased. Muscle pressure pain tolerance threshold was increased, whereas pressure pain threshold was not affected.	Graven-Nielsen et al. (2000)
Bolus 60 μ g/kg; infusion, 60 μ g/kg/min (20 min)	Heat/cold stimulation and allodynia/hyperalgesia to heat/cold stimulation were determined inside the affected skin area and in a contralateral non-painful area in 12 patients with neuropathic pain.	No significant differences in detection thresholds but reduction in pain at threshold for cold pain. Hyperalgesia was reduced.	Jørum et al. (2003)
50, 100, and 150 ng/ml i.v.	Thermal stimulations (cold and heat) and pinprick stimulation in the region of allodynia in 12 patients with neuropathic pain.	Cold threshold and cold pain thresholds increased. No effect on heat stimulation. Reduction in stroking and von Frey evoked allodynic area.	Leung et al. (2001)
0.5 mg/kg	Electrical stimulations in 15 patients after abdominal hysterectomy.	Electric sensation, pain detection and tolerance thresholds increased.	Wilder-Smith et al. (1998)

TABLE 2—Continued.

Drug and Dose	Method	Comment	References
(S)-Ketamine 3-h infusion at 2 $\mu\text{g}/\text{kg}/\text{min}$	Pressure pain stimulation in five different dermatomes and the sum of pressure pain tolerances before, at end of, and after infusion were calculated for nine patients with chronic pancreatitis pain.	The sum of pressure pain tolerances at end of infusion was significantly higher than for placebo but returned to preinfusion values 1 h after end of infusion.	Bouwense et al. (2011)

In a group of patients with nerve injury pain, the effect of ketamine was investigated in response to pain evoked by brush and repetitive pinprick stimuli and acetone. Brush, tactile, pressure, and thermal thresholds were measured. Maximum evoked pain score by repetitive brush and pinprick was reduced significantly by ketamine, but cold allodynia was not attenuated (Gottrup et al., 2006). In another study in patients with neuropathic pain syndromes after trauma (including surgery), the effect of ketamine on cutaneous thermal thresholds and hyperalgesia and on mechanical allodynia was investigated. In the affected skin area, ketamine reduced thresholds for cold pain and light brushing, but did not change the threshold for heat pain. In contralateral, nonaffected skin areas, there were no significant changes (Jørum et al., 2003). Leung et al. (2001) also investigated the effect of ketamine in patients with neuropathic pain and showed a concentration-dependent increase in cold pain thresholds but not on warm or hot pain thresholds. Ketamine had no effect on von Frey hair stimulation thresholds or pain scores but showed a concentration-dependent reduction in stroking pain score and a reduction in stroking-evoked allodynic area and von Frey-evoked allodynic area. Wilder-Smith et al. (1998), investigated sensory changes and pain after elective abdominal hysterectomy. Thresholds were measured using electric constant current skin stimulation on the dominant upper arm, the lateral breast fold 10 cm lateral to the incision, and above the patella. Arm, thoracic, incision, and leg sensory and pain thresholds were increased by ketamine, but differences in sensory processing were not reflected in clinical measures.

The effect of ketamine was also tested in patients with fibromyalgia. Pressure pain thresholds were determined at three bilaterally located tender points and at the tibialis anterior muscle (control). Pain threshold in response to electrical stimuli of the muscle and skin at the tibialis anterior was assessed, and muscular pain and referred pain were assessed by infusion of hypertonic saline into the right tibialis anterior. Mean pressure pain tolerance threshold from the three paired tender points was increased by ketamine. Pressure pain threshold at the anterior tibial muscle was increased after ketamine, whereas pain and referred pain areas after intramuscular infusion of hypertonic saline were reduced. Ketamine had no effect on the pain threshold in response to single electrical stimulus, but the summation ratio to intramuscular and cutaneous electrical

stimuli was decreased (i.e., inhibited temporal summation) (Graven-Nielsen et al., 2000). Two other studies investigated the effect of ketamine in patients with fibromyalgia. In one study, tenderness was measured at tender points and control points with pressure algometry before and 15 min after each injection. Ketamine (0.3 mg/kg) showed a significant reduction in pain changes (Sørensen et al., 1995). In another study in patients with fibromyalgia pressure, pain threshold and pain tolerance increased significantly after ketamine (0.3 mg/kg) in responders (Sørensen et al., 1997).

The analgesic responses to intravenous administration of ketamine were also evaluated in patients with chronic whiplash-associated pain (Lemming et al., 2005). Experimental pain in response to pressure and electrical stimulation was assessed. The pain intensity during experimental muscle pain evoked by intramuscular hypertonic saline was also recorded. Ketamine showed no significant differences in any of the variables (Lemming et al., 2005).

Moreover, (S)-ketamine was tested in patients with chronic pancreatitis pain, where pressure pain thresholds were measured in five different dermatomes and the sum of pressure pain thresholds was calculated before, at the end of, and after infusion of (S)-ketamine (Bouwense et al., 2011). (S)-Ketamine increased the sum of pressure pain thresholds at infusion end but returned to preinfusion level 1 h after infusion (Bouwense et al., 2011).

c. Conclusions. Sigtermans et al. (2010) concluded from their study in patients suffering from chronic complex regional pain syndrome type 1 that ketamine's effect on acute pain is plasma concentration-driven, displaying an on-off effect, and involves inhibition of NMDA receptors involved in the processing of acute pain. NMDA receptors are important players in the plasticity seen in chronic pain. As mentioned previously, dextromethorphan most likely shows analgesic effect through NMDA antagonism, and this could explain the observed effect in response to temporal summation pain, because NMDA receptors are activated in this phenomenon (Staud et al., 2005; Gottrup et al., 2006). Furthermore, the effect of NMDA antagonists can be shown in patients with muscle pain (e.g., fibromyalgia), because enlarged referred pain areas are an indicator of central hyperexcitability (Graven-Nielsen et al., 2000). Even though lower doses were studied in patients with fibromyalgia compared with patients undergoing elective ab-

dominal hysterectomy, an effect of dextromethorphan was demonstrated only in the study in which temporal summation was elicited. This indicates that, regarding NMDA antagonists, it can be more important to evaluate analgesic effects in patients by a proper experimental pain stimulation paradigm than by increasing doses. Supporting this, Graven-Nielsen et al. (2000) could demonstrate no effect of ketamine to single intramuscular electrical stimulation, but an effect on repeated stimulation was demonstrated, indicating a predominant effect on temporal summation. Ayesch et al. (2008) could not demonstrate any effect of ketamine on tactile, pinprick, pressure pain threshold and pressure pain tolerance in patients with temporomandibular joint arthralgia. Nevertheless, it is not always possible to study temporal summation in patients; for example, Ayesch et al. (2008) were not able to specifically study primary and secondary hyperalgesia or temporal summation, because it was not possible to apply repetitively intra-articular pain assessment techniques in these patients. Bouwense et al. (2011) demonstrated an effect of (*S*)-ketamine on pressure pain thresholds. This effect did not outlast the infusion. The authors posited that this may be related to a relatively short infusion period and the low dosage chosen (Bouwense et al., 2011). However, it could also be related to the stimulation paradigm, because temporal summation was not induced. Staud et al. (2005) investigated the effect of dextromethorphan on temporal summation of pain in both patients with fibromyalgia and healthy control subjects. Dextromethorphan attenuated the central integration in both groups. Thus, they concluded that although fibromyalgia patients appear to have enhanced NMDA receptor mechanisms, they do not differ from healthy control subjects in their sensitivity to NMDA receptor antagonism. This is different from findings of opioid effect, where a more pronounced effect is found in the inflamed, up-regulated pain system (Walker, 2003).

3. Adjuvant Analgesics. Adjuvant analgesics such as gabapentanoids and antidepressants have been investigated by experimental pain studies in different patient groups (Table 3).

a. Gabapentin and pregabalin. Gabapentanoids have been investigated in experimental visceral pain in patients with irritable bowel dysfunction (IBS). Gabapentin was investigated in patients with diarrhea-predominant IBS. Pain was evoked by rectal distensions. The distending pressure triggering a first sensation of defecation was not altered by gabapentin, but threshold pressures for bloating, discomfort, and pain were increased (Lee et al., 2005). Pregabalin was studied in patients with IBS and in patients with painful chronic pancreatitis. In patients with IBS, rectal sensitivity was assessed using a barostat technique. Pregabalin significantly increased the sensory thresholds, desire to defecate, and pain (Houghton et al., 2007). In patients with painful chronic pancreatitis, perceptual thresholds in

response to electrical stimulation of the sigmoid with recording of corresponding evoked brain potentials were obtained. Pregabalin increased pain threshold in response to electrical gut stimulation in patients with chronic pancreatitis, whereas no differences in evoked brain potential characteristics were seen (Olesen et al., 2011b).

b. Conclusions. The exact pathophysiology of IBS remains unclear and is probably multifactorial, involving altered intestinal motility, psychosocial factors, autonomic dysfunction, neuroimmune modulation, mucosal inflammation, as well as increased visceral sensitivity as a result of a dysregulated bidirectional communication between the enteric nervous system and the brain (Ghaith et al., 2010). It has been suggested that abnormalities of central nociceptive processing are present in IBS (Verne and Price, 2002). Gabapentin and pregabalin decrease hyperalgesia and allodynia and are widely used in treating neuropathic pain. Gabapentin and pregabalin also exert antinociceptive effects in animal models of neuropathic, surgical, inflammatory, acute, and chronic pain. This was supported by positive findings in the described human experimental pain models in patients (Lee et al., 2005; Houghton et al., 2007). The mechanism of action is not fully known, but part of the therapeutic action on neuropathic pain is thought to involve voltage-gated calcium ion channels (Field et al., 2006; Bauer et al., 2010). In patients with chronic pancreatitis, which is also thought to be a neuropathic pain disorder (Drewes et al., 2008), the experimental measure translated into a clinical efficacy, confirmed by traditional questionnaire endpoints (Olesen et al., 2011a).

The study by Lee et al. (2005) demonstrated that for adjuvant analgesics as well, perception thresholds for discomfort as assessed by experimental rectal distension can probably not be considered nociceptive thresholds. This was supported by the study by Olesen et al. (2011b), where it was demonstrated that patients with chronic pancreatitis had increased pain thresholds in response to experimental gut stimulation after pregabalin treatment compared with placebo, although sensation thresholds were not modified. As for opioids, it could be speculated that gabapentin in the dose investigated by Lee et al. (2005) is fairly selective in its ability to attenuate noxious inputs and to have only modest effects on non-noxious somatic sensations. However, an effect of pregabalin on sensory thresholds from the first sensation was found in another study (Houghton et al., 2007). The difference between the outcomes of the two studies could be related to differences between mechanisms of action of pregabalin and gabapentin but also to the fact that different dosing regimens were used (Lee et al., 2005; Houghton et al., 2007). As in experimental human pain models in healthy volunteers, there seems to be a nonlinear relation between dose and effect in patients as well. It has been suggested that the antinociceptive mechanisms of pregabalin action are mediated primar-

TABLE 3
Adjuvant analgesic

Drug and Dose	Method	Comment	References
Gabapentin 3-day treatment with gabapentin 300 mg/day and then 600 mg/day for 2 days	Mechanical distension of rectum in 40 patients with diarrhea-predominant IBS.	Pressure pain thresholds increased.	Lee et al. (2005)
Pregabalin 3 weeks' oral pregabalin titrated to a final dose of 200 mg ×3 Escalating doses of pregabalin (300–600 mg/day) for 3 weeks	Rectal distension in 26 patients with IBS with rectal hypersensitivity. Electrical stimulation of the sigmoid with recording of corresponding evoked brain potentials in 13 patients with painful chronic pancreatitis.	Pregabalin increased the sensory thresholds for first sensation and moderate pain. Increase in pain threshold to electrical gut stimulation. No differences in evoked brain potential characteristics were seen.	Houghton et al. (2007) Olesen et al. (2011)
Amitriptyline 75 mg daily in 32 weeks	Pressure pain stimulations at the dorsum of a finger and of the temporal region of the head as well as electrical stimulation of the labial commissure of the mouth in 33 patients with chronic tension-type headache.	No significant effects.	Bendtsen and Jensen (2000)
75 mg daily for 6 weeks	Mechanical pressure pain applied to vertex of the head in 24 patients with chronic tension-type headache.	The experimental pain sensitivity for mild and moderate mechanically induced pressure pain was not altered. Reduction in suprathreshold pain sensitivity for severe pain.	Göbel et al. (1994)
10 mg daily in 2 months	Laser pulse stimulation in 18 patients with chronic tension-type headache.	The pain rating of laser stimulus was not different at any of the stimulated sites. The amplitude of P2 response elicited by stimulation of pericranial zones showed a reduction.	de Tommaso et al. (2006)
50 mg daily for 4 weeks	Cerebral activation during rectal distension was assessed with fMRI in 19 patients with IBS.	No effect on rectal pain during distension. Reduced pain related cerebral activations in the perigenual ACC and the left posterior parietal cortex, but only during stress.	Morgan et al. (2005)
10 mg at bedtime for 2 weeks, then 25 mg at bedtime for 4 weeks	Rectal distension in 12 patients with IBS.	Pain threshold to rectal distension increased.	Poitras et al. (2002)
Amitriptyline 50 mg for 4 weeks	Esophageal distention in seven patients with functional dyspepsia.	No significant effect.	Mertz et al. (1998)
Imipramine 25 mg for 1 week, then 50 mg for 3 weeks	Cardiac pain stimulation by right ventricular electrical stimulation and esophageal balloon distension in 22 patients with noncardiac chest pain.	Significant reduction in the prevalence of chest pain provoked by right ventricular electrical stimulation. No change in esophageal sensitivity to balloon distention.	Cannon et al. (1994)
Fluoxetine 20 mg daily for 6 weeks	Rectal distension in 40 patients with IBS.	No significant effect.	Kuiken et al. 2003

ACC, anterior cingulate cortex.

ily through subcortical mechanisms, because no effects were seen as changes in characteristics of evoked brain potentials (Olesen et al., 2011b).

b. Amitriptyline. Amitriptyline is a tricyclic antidepressant that inhibits both serotonin and noradrenaline reuptake and has been tested in three studies in patients with chronic tension-type headache (Göbel et al., 1994; Bendtsen and Jensen, 2000; de Tommaso et al., 2006). In a study by Bendtsen and Jensen (2000), ami-

triptyline did not affect pressure pain thresholds at the finger and the temporal region or the electrical pain threshold at the mouth. Göbel et al. (1994) found that amitriptyline reduced suprathreshold pain sensitivity in response to mechanical pressure applied to the vertex (experimental induced headache). In a third study, evoked brain potentials in response to laser stimulation of the skin at the dorsum of the right hand and above different muscles in the neck and head were recorded.

Amitriptyline reduced the vertex P2 amplitudes at the neck point, masseter, and temporal sites that were correlated with the percentage rate of reduction of headache frequency (de Tommaso et al., 2006).

Amitriptyline was also studied in patients with IBS in two studies. Morgan et al. (2005) investigated cerebral activation with fMRI during rectal distension. Amitriptyline reduced pain related cerebral activations in the perigenual anterior cingulate cortex and the left posterior parietal cortex, but only during stress. However, reductions in brain activation were not definitely linked to reduced sensitivity to rectal pain. Poitras et al. (2002) evaluated visceral sensitivity in patients with IBS and found that the pain threshold in response to rectal distension increased after drug treatment. In patients with functional dyspepsia, amitriptyline showed no changes in perception of gastric distension (Mertz et al., 1998).

c. Imipramine. Imipramine was studied in patients with noncardiac chest pain. No change in esophageal sensitivity to balloon distension was found, whereas imipramine caused a reduction in the chest pain provoked by right ventricular electrical stimulation (Cannon et al., 1994).

d. Fluoxetine. Fluoxetine is a selective serotonin-reuptake inhibitor and was studied in patients with IBS but did not alter the threshold for discomfort/pain during rectal distensions (Kuiken et al., 2003).

e. Conclusions. The results showed variation in effect of amitriptyline on experimental pain. Different doses, different patient groups, and different models were used; therefore, it is difficult to compare the results. However, objective measurements such as fMRI and laser-evoked potentials are potential models when investigating the central effect of amitriptyline, as shown with the studies performed by Morgan et al. (2005) and de Tommaso et al. (2006). It was concluded that interventions at the supraspinal levels (as with amitriptyline) improved the outcome of headache (de Tommaso et al., 2006). However, a significant weakness of de Tommaso et al.'s (2006) study design was the lack of placebo.

The effect of tricyclic antidepressants in, for example, patients with IBS is unlikely to be due to the antidepressant effect, because a positive effect is mainly seen in nondepressive patients, the dose is generally below antidepressant dose, and treatment response occurs earlier than antidepressant effect. Morgan et al. (2005) postulated that the effect of amitriptyline is central as a result of reduced pain-related cerebral activations. Bendtsen and Jensen (2000) concluded that their findings indicate that amitriptyline elicits its analgesic effect in chronic myofascial pain by reducing the transmission of painful stimuli from myofascial tissues rather than by reducing overall pain sensitivity. They suggested that this effect could be caused by a segmental reduction of central sensitization in combination with a peripheral antinociceptive action. The studies above in-

dicate that the analgesic effects of tricyclic antidepressants are complex.

Rectal pain thresholds were increased in patients with IBS treated with amitriptyline, and the effect was correlated to clinical improvement of the gastrointestinal symptoms (Poitras et al., 2002). In contrast, Mertz et al. (1998) found no effect of amitriptyline on the perceptual responses to gastric distensions in patients with functional dyspepsia. These authors speculated that amitriptyline conceivably had an effect on pain modulatory brain systems that reduce the affective component of pain and thereby increased tolerance without altering perceptual thresholds. The same was demonstrated by Göbel et al. (1994); no effect of amitriptyline was found for mild and moderate mechanically induced pressure pain at vertex in patients with chronic tension-type headache, whereas a significant reduction in the suprathreshold pain sensitivity for severe pain occurred during the course of treatment. Thus, when evaluating antidepressants in experimental pain in patients, it is important to use methods of suprathreshold stimulation. Moreover, because of the conflicting results in experimental trials involving this drug class, a combination of objective and subjective assessments are highly recommended when the central analgesic effect of antidepressants is evaluated in experimental pain in different patient groups.

4. 5-Hydroxytryptamine-3 Receptor Antagonists. 5-hydroxytryptamine-3 (5-HT₃) antagonists are known to act on both peripheral and central 5-HT₃ receptors (Riering et al., 2004). The indication is nausea and vomiting, but 5-HT₃-antagonists may also have antinociceptive effects. Three different 5-HT₃-antagonists have been tested in experimental pain models in patients (Table 4).

a. Alosetron. Alosetron was tested in patients with IBS in three different studies (Delvaux et al., 1998; Thumshirn et al., 2000; Mayer et al., 2002). Alosetron increased bag volumes at the time of first sensation of abdominal pain (Delvaux et al., 1998). This was supported by a PET study in which alosetron decreased activity in amygdala, ventral striatum, hypothalamus, and infragenuary cingulate gyrus after rectosigmoid distension (Mayer et al., 2002). In contrast, another study could not demonstrate an effect on sensation by rectal balloon distension with a barostat (Thumshirn et al., 2000).

b. Granisetron. Granisetron was tested in patients with fibromyalgia to pressure pain threshold over the masseter muscle. No significant effect was seen (Ernberg et al., 2003). Granisetron was also tested in patients with IBS using rectal distension. Granisetron caused a dose-dependent reduction in rectal sensitivity, manifested by an increase in the threshold volumes at which the sensations of gas, desire to defecate, urgency, and discomfort were perceived. This reached signifi-

TABLE 4
5-HT₃ antagonists

Drug and Dose	Method	Comment	References
Alosetron 0.25 (<i>n</i> = 8) or 4 mg (<i>n</i> = 8) twice daily for 7 days	Distension of colon in 16 patients with IBS.	Effect on mechanical stimulation at both the first sensation threshold and the perception of abdominal pain.	Delvaux et al. (1998)
1, 2, or 4 mg twice daily for 3 weeks	Rectosigmoid distension and PET scan in 37 patients with IBS.	No effects on rectal distension. Reduced regional cerebral blood flow in various structures relating to the brains pain matrix.	Mayer et al. (2002)
1 or 4 mg twice daily for 4 weeks	Rectal balloon distension in 25 patients with IBS.	No significant effects.	Thumshirn et al. (2000)
Granisetron 1 mg i.m.	Pressure pain threshold over the masseter muscle in 18 patients with fibromyalgia.	No significant effect.	Ernberg et al. (2003)
40 or 160 μ g/kg i.v.	Threshold volumes for sensation of gas, desire to defecate, urgency, and discomfort in 12 patients with IBS.	Significant difference for all sensations at the higher dose level.	Prior and Read (1993)
Ondansetron 0.15 mg/kg single i.v.	In 12 patients with IBS, the stomach and the rectum were distended, and somatic pain was evaluated by immersion of a hand in cold water.	No significant effect.	Zighelboim et al. (1995)

cance for all sensations at the higher dose level (Prior and Read, 1993).

c. Ondansetron. Several studies were performed in patients with IBS, and most had positive outcomes (Prior and Read, 1993; Delvaux et al., 1998; Mayer et al., 2002). However, one study in patients with diarrhea-predominant IBS had negative outcome, because ondansetron did not alter visceral (barostat) or somatic (immersion of the hand in cold water) perception scores (Zighelboim et al., 1995). An effect of multiple dosing for 1 week of the 5-HT₃-antagonist alosetron on abdominal pain induced by distension of the colon was found to increase colonic compliance without affecting the pressure required for the perception of the first sensation of abdominal pain (Delvaux et al., 1998), whereas no effect was found in patients with fibromyalgia (Ernberg et al., 2003).

d. Conclusions. The pathophysiology of IBS is multifactorial, but visceral hypersensitivity is likely to be an important component in most patients (Delvaux et al., 1998). The results of colonic distension tests cannot be truly predictive, but any change in response to this stimulus can be indicative of potential benefit. An increase in colonic compliance could result from an inhibition of colonic tone, allowing the colon to adapt more easily to larger volumes of distension. Therefore, a local action of, for example, alosetron on the colonic wall could be responsible for a reduction in perception of distension. Thus, if this is true, it could explain the negative outcome in patients with fibromyalgia (Ernberg et al., 2003). Assessment of perception to distension could have been supplemented by other assessments, such as a multiassessment approach. For example, Mayer et al. (2008) proposed that translational pharmacological brain imaging approaches in both animal models and

humans (in addition to novel clinical trial designs) have the potential to demonstrate effect of 5-HT₃-antagonists on visceral pain. This was previously demonstrated by Mayer et al. (2002), who found decreases in brain activity caused by rectosigmoid distension after treatment with 5-HT₃-antagonists. Therefore, inclusion of brain imaging for visceral pain could improve and accelerate the drug discovery and development process, including the identification of more effective compounds for treatment of GI disorders (Mayer et al., 2008).

B. Opioids

The opioids alfentanil, asimadoline, fedotozine, fentanyl, morphine, oxycodone, and tramadol have all been studied in experimental pain in patients (Table 5). Opioids are described in two separate sections as short-acting and longer acting opioids. The results from studies of opioid effects are discussed in general in the end of this section.

1. Short-Acting Opioids.

a. Alfentanil. Alfentanil is a μ -receptor agonist with a short duration of action and has been tested in two studies of experimental skin pain in patients with neuropathic pain. Jørum et al. (2003) investigated the effect of alfentanil by use of heat and cold thresholds. They found that alfentanil decreased allodynia and hyperalgesia in the affected skin area. Heat pain detection threshold was significantly elevated. In contralateral, nonaffected skin areas, there were no significant changes. Leung et al. (2001) investigated the effect of alfentanil in patients with neuropathic pain in different locations and found that the drug showed a concentration-dependent increase in thresholds in response to cold stimulation. The heat thresholds were not affected. There was no effect on von Frey hair stimulation thresh-

TABLE 5
Opioids

Drug and Dose	Method	Comment	References
Alfentanil Bolus 7 $\mu\text{g}/\text{kg}$ followed by infusion 0.6 $\mu\text{g}/\text{kg}/\text{min}$ for 20 min	Heat and cold stimulations and mechanical allodynia/hyperalgesia in response to heat/cold stimulation in 12 patients with neuropathic pain.	Allodynia and hyperalgesia to cold as well as allodynia to mechanical stimulation were reduced. Heat pain detection threshold was elevated.	Jørum et al. (2003)
Single infusion via computer controlled pump, programmed to target plasma levels of 25, 50 and 75 ng/ml i.v.	Thermal stimulation, pain in response to pinprick and hyperalgesic area were measured in 12 patients with neuropathic pain.	Cold pain threshold increased, whereas there was no effect on heat pain thresholds. There was a reduction in pinprick pain and in stroking-evoked allodynic area. This was not the case for von Frey evoked allodynic area, where no effect was observed.	Leung et al. (2001)
Meperidine 100 mg single dose	Electrical stimulation in 20 patients with dental pain.	No significant effect.	Carnes et al. (1998)
Morphine 0.075 mg/kg i.v. single dose	Brush (allodynia), repeatedly pricking the affected skin area with von Frey, tactile von Frey stimulation, and thermal stimulation in cervical, thoracic, lumbar, and facial regions in eight patients with postherpetic neuralgia.	No significant change in pain thresholds for thermal or tactile sensation. Allodynia was significantly decreased. Pain to repeated pricking stimulation was significantly increased.	Eide et al. (1994)
30 mg oral single dose	Mechanical, thermal, and electrical stimulation in the skin, muscles (no heat), and esophagus 10 in patients with chronic pancreatitis.	In esophagus mechanical pain tolerance threshold was increased but heat and electrical evoked pain were unaffected. No effects in skin and muscle pain.	Staahl et al. (2007)
Continuous infusion for 48 h resulting in a total of 60.7 \pm 18 mg i.v.	Rectal distension and transcutaneous electrical skin stimulation in 50 patients undergoing abdominal hysterectomies.	Increased pain tolerance to rectal distension. No difference in trans-cutaneous electrical stimulation.	Wilder-Smith et al. (1999a)
10 mg four times daily	Rectal distension thresholds in 25 patients with chronic pancreatitis pain.	No significant effect.	Wilder-Smith et al. (1999b)
10 mg i.v. single dose	Pressure stimulation at tender and control points in nine patients with fibromyalgia.	No significant effect.	Sørensen et al. (1995)
0.3 mg/kg i.v. single dose	Pressure stimulation at tender and nontender point areas in 18 patients with fibromyalgia.	Patients were classified as responders or nonresponders according to clinical pain intensity ratings taken before, during, and after the tests. Pressure pain thresholds significantly increased in responders but not in nonresponders.	Sørensen et al. (1997)
0.3 mg/kg 30 min infusion	Pressure, intramuscular, and cutaneous electrical stimulation was recorded in 17 patients with diagnosed whiplash-syndrome.	No significant effects.	Lemming et al. (2005)
Oxycodone 15 mg oral single dose	Mechanical, thermal, and electrical stimulation in the skin, muscles (no heat), and esophagus in 10 patients with chronic pancreatitis	Mechanical and heat pain tolerance threshold were increased in skin. In muscles, mechanical pain tolerance threshold was increased. In esophagus, mechanical and heat pain thresholds were increased. Electrical pain thresholds were unaffected in all tissue.	Staahl et al. (2007)
Fentanyl High dose (112 μg bolus followed by 0.04 $\mu\text{g}/\text{kg}/\text{min}$ infusion) or low dose (56 μg bolus followed by 0.02 $\mu\text{g}/\text{kg}/\text{min}$ infusion) 0.8 and 1.1 $\mu\text{g}/\text{kg}$ single doses	Rectal distension in 10 patients with IBS.	Perception thresholds increased dose-dependently.	Lembo et al. (2000)
0.75 or 1.5 $\mu\text{g}/\text{kg}$ i.v. single dose	Heat stimulation of the skin to 12 patients with low back pain.	Reduced pain responses.	Price et al. (1986)
0.75 or 1.5 $\mu\text{g}/\text{kg}$ i.v. single dose	Heat (single and repeated) and cold (pulse) stimulation of the skin in 15 patients with fibromyalgia.	Only repeated cold pain was attenuated.	Price et al. (2002)
3 $\mu\text{g}/\text{kg}$ i.v. single short infusion	Electrical stimulation in the skin in 15 patients undergoing back surgery.	Pain thresholds were increased.	Wilder-Smith et al. (1996)

TABLE 5—Continued.

Drug and Dose	Method	Comment	References
1.5 $\mu\text{g}/\text{kg}$	Electrical skin stimulation in 15 patients after abdominal hysterectomy	All thresholds were increased.	Wilder-Smith et al. (1998)
Asimadoline 0.5 mg	Phasic distension of colon in 20 patients with IBS.	Area under curve of pain intensity decreased significantly.	Delvaux et al. (2004)
Fedotozine 100 mg	Phasic distension of colon in 14 patients with IBS.	Thresholds of perception were increased.	Delvaux et al. (1999)
Tramadol 100 mg	Electrical stimulation at or distant from the incision were studied in 120 patients who had elective cesarean delivery	No significant differences for tramadol, but an increase was seen for the combination tramadol plus diclofenac.	Wilder-Smith et al. (2003)
732.5 \pm 152 mg i.v.	Rectal distension and transcutaneous electrical stimulation in 50 patients undergoing abdominal hysterectomies	No significant effects.	Wilder-Smith et al. (1999a)
50 mg four times daily	Rectal distension in 25 patients with chronic pancreatitis pain.	Rectal distension thresholds increased.	Wilder-Smith et al. (1999b)
100 mg p.o.	Electrical skin stimulation in 60 patients with osteoarthritis.	Reduced pain thresholds.	Wilder-Smith et al. (2001)

olds, but a reduction in stroking-evoked allodynic area was found.

b. Meperidine. Meperidine is a μ -opioid receptor agonist and a fast-acting opioid analgesic that was tested in patients with dental pain. In the study, no increase in pain threshold in response to electrical stimulation of the pulp could be detected (Carnes et al., 1998).

2. Longer Acting Opioids.

a. Traditional μ -receptor agonists. The effect of morphine was studied in patients with postherpetic neuralgia. Morphine had no effect on thresholds for warm, cold, or heat stimulation or on tactile sensation. Pain evoked by non-noxious stimulation of the skin (allodynia) was inhibited by morphine, whereas wind-up-like pain (repeated pricking of the affected skin area) was significantly increased by morphine (Eide et al., 1994). Staahl et al. (2007) performed an experimental pain study in patients with chronic pancreatitis and found that mechanical, heat and electrical pain in skin and mechanical and electrical muscle pain was unaffected by morphine. Morphine increased esophageal mechanical pain tolerance threshold, whereas esophageal heat and electrical pain thresholds were unaffected. Wilder-Smith et al. (1999a) also investigated the effect of morphine in patients with chronic pancreatitis but found no effect on rectal distension thresholds. In another study by Wilder-Smith et al. (1999b), morphine increased pain tolerance to rectal distension and to electrical skin pain on the right shoulder in patients undergoing abdominal hysterectomies. However, morphine showed no effect on transcutaneous electric sensation or skin electric pain tolerance thresholds tested 5 cm from the incision wound (Wilder-Smith et al., 1999b). The effect of morphine has also been investigated in patients with fibromyalgia. In one study, there was no effect on pressure pain intensity measured at tender points and control points before and 15 min after each injection (Sørensen et al., 1995). Another study in patients with fibromyalgia examined four

tender points with an electronic pressure algometer. Two non-tender-point areas were examined in the same way. Pressure pain threshold and pain tolerance increased significantly after morphine administration (0.3 mg/kg) in patients characterized as responders (Sørensen et al., 1997). The analgesic responses to intravenous administration of morphine were also evaluated in patients with chronic whiplash-associated pain (Lemming et al., 2005). Experimental pain assessments were performed on the lower legs, but there was no effect on pressure pain thresholds, intramuscular and cutaneous electrical stimulations, and intramuscular hypertonic saline. (Lemming et al., 2005).

Oxycodone is an opioid agonist with affinity for the μ -opioid receptor and a low affinity for the κ -opioid receptor. The effect of oxycodone was investigated only in an experimental pain study in patients with chronic pancreatitis, where the effect was better than morphine. For skin stimulations, mechanical and heat pain tolerance thresholds were increased, whereas electrical pain tolerance thresholds were unaffected. For muscle stimulations, mechanical pain tolerance threshold was increased and electrical pain tolerance threshold was unaffected. For esophageal stimulations, both mechanical and heat pain thresholds were increased, whereas electrical pain tolerance threshold was unaffected (Staahl et al., 2007).

Fentanyl dose-dependently increased perception thresholds in response to rectal distension in patients with irritable bowel syndrome (Lembo et al., 2000). In patients with low back pain, fentanyl patches caused increased pain threshold in response to heat stimulation in the skin on the forearm (Price et al., 1986). In patients with fibromyalgia, no effect of fentanyl was found on heat skin pain, whereas both repeated heat and cold stimuli were attenuated by fentanyl (Price et al., 2002). Fentanyl was also investigated in a study in patients undergoing elective herniated intervertebral disc sur-

gery. Sensation, pain detection, and tolerance thresholds in response to electrical stimulation were measured before operation and 1, 2, 4, 6, 24 h, and 5 days after operation and were increased after fentanyl administration (Wilder-Smith et al., 1996). In another study by Wilder-Smith et al. (1998), the effect of fentanyl was investigated in patients undergoing elective abdominal hysterectomy. Thresholds were measured using electrical skin stimulation on the arm, the lateral breast fold, 10 cm lateral to the incision and above the patella. Fentanyl was found to increase electrical pain thresholds compared with baseline 1 to 24 h after surgery for all measurement sites, but these differences in sensory processing were not reflected in clinical measures (Wilder-Smith et al., 1998).

b. κ -Receptor agonists. Asimadoline is a full κ -opioid agonist, with high affinity and selectivity. It exerts its effect through a peripheral action, not crossing the blood-brain barrier in significant amounts, because it is actively transported out of the brain via a *p*-glycoprotein (Jonker et al., 1999). One study demonstrated that asimadoline decreased the perception of pain induced by colonic distension in patients with IBS, whereas it did not influence perception of nonpainful colonic distensions (Delvaux et al., 2004).

Fedotozine acts mainly as a κ -opioid agonist and has been studied in patients with IBS. In IBS, sensory thresholds were elicited by left colon phasic distention up to a sensation of abdominal pain. Fedotozine increased thresholds of first perception and pain (Delvaux et al., 1999).

3. Opioids with Mixed Binding Profile.

a. Tramadol. Tramadol exerts actions at the μ -opioid receptor as well as the noradrenergic and serotonergic systems and was investigated in four studies all performed by Wilder-Smith et al. (1999a,b, 2001, 2003a). One study in patients who had undergone elective cesarean delivery demonstrated that pain thresholds at or distant from the incision significantly increased after surgery only when tramadol was combined with diclofenac and unaffected by tramadol alone (Wilder-Smith et al., 2003a). Another study was performed in patients undergoing abdominal hysterectomies. Skin pain tolerance thresholds in the incisional dermatome, pain tolerance threshold at the shoulder, and rectal distension pain tolerance pressure thresholds were unaffected by tramadol (Wilder-Smith et al., 1999b). In a study in patients with chronic pancreatitis, rectal distension threshold increased with tramadol (Wilder-Smith et al., 1999a). In patients with osteoarthritis, electrical sensation and pain thresholds over the osteoarthritic joint and at a distant location were increased during treatment (Wilder-Smith et al., 2001).

4. Conclusions.

The lack of effect of morphine in patients with postherpetic neuralgia, reported by Eide et al. (1994), could be due to a low dose of morphine (0.075 mg/kg) Sørensen et

al. (1995, 1997) investigated the effect of morphine in two different studies; in their first study; they found no effect of morphine (10 mg i.v.) on experimental pain in patients with fibromyalgia, whereas an effect of a higher dose (0.3 mg/kg) was found in the later study. Supporting this Leung et al. (2001) found a dose-dependent increase of alfentanil in cold pain thresholds, and it was demonstrated that fentanyl dose-dependently increased the perception thresholds in patients with IBS (Lembo et al., 2000). Thus, as in healthy volunteers, it is important to evaluate the right dose of opioids in experimental pain studies in patients.

The fast acting μ -receptor agonist alfentanil increased the cold pain threshold and hyperalgesia to cold in the skin in the affected skin areas in two studies after intravenous administration (Leung et al., 2001; Jørum et al., 2003). This could be caused by a pronounced central effect of the drug, because central sensitization mechanisms are probably involved in cold hyperalgesia (Woolf and Mannion, 1999). However, in the study by Jørum et al. (2003), analgesic effect could not be demonstrated in the contralateral, nonaffected skin areas even though contralateral decrease in cold pain thresholds were demonstrated compared with healthy volunteers. Therefore, an effect on peripheral opiate binding sites could be an alternative mechanism as a result of de novo synthesis and peripherally directed axonal transport of opiate receptors in chronic pain states (Walker, 2003). Opioids might suppress spontaneous pain via central inhibitory mechanisms, whereas there seem to be peripheral mechanisms of opioids on pre-existing neuropathic pain states (Leung et al., 2001).

In patients undergoing abdominal hysterectomies, both somatic and visceral stimulations were unaffected by tramadol (Wilder-Smith et al., 1999b), whereas rectal distension threshold pressures increased with tramadol in patients with chronic pancreatitis (Wilder-Smith et al., 1999a). This illustrates that the pain system and the opioid system are up-regulated or changed differentially in different pain states, and highlights the importance of investigating analgesic effect in different chronic pain types and not only in postoperative pain. This was supported by the study in patients with osteoarthritis in which sensation and pain thresholds over the osteoarthritic joint and at a distant location were increased after treatment with tramadol (Wilder-Smith et al., 2001). However, with strong opioids, it is possible to demonstrate effect on postoperative pain, because both fentanyl and morphine were effective in patients undergoing elective disc surgery or abdominal hysterectomies (Wilder-Smith et al., 1996, 1998, 1999b).

First pain from, for example, single heat stimulation, which is mediated by selective input from A δ afferents (Handwerker and Kobal, 1993), showed no effect of fentanyl in patients with fibromyalgia, whereas the second pain summation tests, which are considered to be primarily associated with C fiber stimulation (Handwerker

and Kobal, 1993), showed an effect of fentanyl compared with placebo (Price et al., 2002). This finding can have important implications for control of clinical pain, because temporal summation may reflect mechanisms of the beginning stages of central hyperalgesia associated with persistent pain conditions such as those seen in fibromyalgia. This highlights the importance of studying the second pain, when analgesic effects are evaluated in experimental pain settings in patients, because opioids seem to affect the second pain more than the first pain (Handwerker and Kobal, 1993). An increase in pharmacological sensibility induced by an inflammatory agent during disease could be due to C fiber polymodal nociceptors being particularly susceptible to sensitization phenomena. In addition, several C fibers are silent under normal conditions but respond to thermal and mechanical stimuli in inflamed tissue (Le Bars et al., 2001). However, regarding heat stimulation of the skin, analgesia was not detected after administration of morphine (Eide et al., 1994; Staahl et al., 2007). Whether this is related to heating rate or experimental bias in the patient studies cannot be determined and awaits further studies.

Electrical stimulation can be used to detect a central effect of opioids. Pain evoked by electrical stimulation of the skin however, was rarely attenuated by morphine, oxycodone, or tramadol in patient studies (Wilder-Smith et al., 1999a,b, 2003b; Staahl et al., 2007). Moreover, electric pulp tests are affected little by meperidine; Carnes et al. (1998) concluded that electric pulp tests stimulate sharp pain, that there is a difference between sharp pain and dull pain analgesia, and that sharp pain is not significantly altered by opioids (Carnes et al., 1998). The negative results in the study with tramadol could be caused by the fact that the effect was evaluated at pain detection threshold (Brennum et al., 1993; Wilder-Smith et al., 2001). Few studies found an effect of opioids on electrical skin stimulation; an effect of tramadol was demonstrated on the pain detection threshold for electrical stimulations in one study in patients with osteoarthritis (Wilder-Smith et al., 2001). An effect of fentanyl was found on electrical stimulation of the skin in patients undergoing back surgery or abdominal hysterectomy (Wilder-Smith et al., 1996; Wilder-Smith et al., 1998).

The effect of opioids on muscle pain in patients has so far been investigated in only one study: Staahl et al. (2007) found effect of oxycodone in response to mechanically induced muscle pain in patients with chronic pancreatitis, whereas no effect in response to intramuscular electrical stimulation could be detected for either morphine or oxycodone (Staahl et al., 2007). Nevertheless, one study is insufficient to make strong conclusions on the effect of opioids on muscle pain. Moreover, possible confounders in the study were that only two of the patients were opioid-naive and the number of patients included in the study was low, thus limiting interpreta-

tion of the results (Staahl et al., 2007). In addition, because the patients at inclusion were treated with morphine, tolerance was probably present and could account for the lack of analgesic effect of morphine in some of the pain tests (Staahl et al., 2007).

Several studies have investigated the effect of opioids by use of esophageal distension in different patient groups. Pain from esophageal distension was well modulated by opioids; asimadoline (Delvaux et al., 2004), fedotozine (Delvaux et al., 1999), fentanyl (Lembo et al., 2000), morphine (Wilder-Smith et al., 1999b; Staahl et al., 2007), oxycodone (Staahl et al., 2007), and tramadol (Wilder-Smith et al., 1999b) showed effect on this experimental pain stimulation in patients. Staahl et al. (2007) investigated the effect of morphine and oxycodone on pain induced by distension, heat, and electrical stimulation of esophagus and found differentiated effects of the two drugs; oxycodone was superior to morphine in attenuating visceral pain. An explanation could be differential analgesic profiles of opioids that might be caused by action on different opioid receptors. Animal studies have shown that κ -opioid agonists attenuate visceral pain (Sengupta et al., 1996). Moreover, experiments with animals indicate that κ -opioid receptor is up-regulated in response to peripheral inflammation (Sengupta et al., 1999) and that oxycodone could be a more potent κ -agonist compared with morphine (Ross and Smith, 1997). The resulting barrage of noxious activity and the inflammatory pain component in patients with chronic pain and inflammation has been hypothesized to effectuate peripheral, spinal, and supraspinal changes in the pain system (Cervero, 2000). These changes may include altered expression and activity of opioid receptors (Stanfa and Dickenson, 1995; Sengupta et al., 1999); for example, up-regulation of κ -opioid receptors (Sengupta et al., 1999), thereby also explaining the demonstrated effect of the κ -opioid agonists, asimadoline and fedotozine, on colon distension in patients with IBS (Delvaux et al., 1999; Delvaux et al., 2004). The effect of fedotozine has also been demonstrated clinically in patients with nonulcer dyspepsia and in patients with functional dyspepsia (Fraitag et al., 1994; Read et al., 1997).

Perception thresholds for discomfort as assessed by experimental rectal distension can probably not be considered nociceptive thresholds; they are not associated with significant heart rate responses and are significantly lower than visceral pain thresholds reported in the literature (Lembo et al., 2000). In general, opioids are thought to be fairly selective in their ability to attenuate noxious inputs and to have only modest effects on non-noxious somatic sensations. This was also demonstrated in healthy volunteers, where strong tonic pain was attenuated more than short lasting pain and non-painful sensations (Staahl et al., 2009a). The same was shown in IBS patients by Delvaux et al. (2004), who showed that the κ -receptor agonist asimadoline de-

creased only the perception of painful colonic distension and not the perception of nonpainful colonic distension. However, others argue that diffuse low-intensity pains are reduced by opiates to a greater extent than are sharp intense pains and that opiates have effects throughout the nociceptive range. Therefore, it may not be necessary to use severe and long-duration experimental pains to demonstrate analgesic effects (Price et al., 1986). If the applied method is sensitive enough (and, e.g., evaluates visceral pain), it is possible to detect the effect of a well established μ -opioid analgesic compound, such as fentanyl, on perception of nonpainful and painful visceral stimuli (Lembo et al., 2000). This could be explained by fentanyl's having a greater attenuating effect on unpleasantness of visceral stimuli by activating brain regions, such as the perigenual anterior cingulate and prefrontal cortices, and possibly periaqueductal gray, that have been found to show a blunted response to the anticipation of an unpleasant visceral stimulus (Lembo et al., 2000).

Different outcomes could be the result of heterogeneity in responses to different pharmacological challenges in patients. This could be a reflection of heterogeneity in many areas, such as etiology, pain processing, genetics, and psychosocial factors. Moreover, some patients may have several active pain mechanisms that have to be targeted in clinical practice. Simultaneous treatment with several analgesic drugs with effects at different levels and receptors might be necessary when designing the pharmacological treatment of an individual patient.

X. Recommendations and Conclusion

Most of the reviewed studies found an effect of the tested analgesics. Lack of demonstrating analgesic effect could be due to 1) use of experimental models not activating specific pain mechanisms thought to be involved in the analgesic action of the drug investigated, 2) not using several modalities and/or activating several tissues as in clinical diseases, or 3) inadequate dose. The experimental pain models should also be thoroughly tested for reliability, should be internally valid (i.e., design must limit bias possibility to a minimum), and should aim for external validity (clinically useful in a way that the result must also be relevant to analgesic mechanisms or a definable group of patients in a particular clinical setting) (Rothwell, 2005; Drewes and Gregersen, 2006). External validity of the model of rectal distension was demonstrated by Morgan et al. (2005), where patients reported that the discomfort of pain induced by rectal distension was similar to their IBS symptoms. A crossover design gives the advantage of minimizing the interindividual variation and increases the statistical power. Nevertheless, disadvantage of a crossover design is carryover effect and regression toward the mean.

The characteristics of the noxious stimuli may be important in bridging experimental and clinical pain responses. Overall, suprathreshold pain stimuli are more clinically relevant than responses to pain threshold level (Edwards et al., 2005). This was seen from studies in both healthy volunteer and patients; pain intensities above the pain detection threshold were attenuated to a higher degree than intensities below the pain threshold.

Assessment with neurophysiologic methods and imaging is valuable as a supplement to psychophysical methods, mainly for explanation of analgesic mechanisms. Statistical considerations may also be important; associations between clinical pain and experimental pain responses may be most apparent when studying extreme groups (e.g., the most and least pain-sensitive patients) (Edwards et al., 2005).

Applying experimental pain to both healthy volunteers and to patients can be beneficial, because differentiated outcomes can give further information about pain physiology and pathophysiology. An example is the differences in effect of oxycodone and morphine demonstrated in patients with chronic pancreatitis (Staahl et al., 2007), which were not present when healthy volunteers were investigated in a previous study using the same experimental pain model (Staahl et al., 2006a). Nevertheless, the difference in opioid effect could also be demonstrated in healthy volunteers when a translational human experimental pain model including hyperalgesia was used (Olesen et al., 2010a). Therefore, experimental pain models in healthy volunteers should aim for translation to the clinical situation, where inflammation and hyperalgesia is present.

Two studies by Sørensen et al. (1995, 1997) looked at responders versus nonresponders, which could explain positive findings. The exclusion of nonresponders in pharmacological trials is described as enriched enrollment study design. Eide et al. (1995) used this paradigm as well; only five patients that reported pain relief after acute intravenous injection of ketamine were included, and the study had a positive outcome. Enriched enrollment is believed to add both to trial sensitivity and to the measured effect of an intervention (Straube et al., 2008). An example of enriched enrollment was seen in a recent study by Krarup et al. (2011), where only subjects who showed sensitization to acid perfusion of the esophagus were included. However, the effects of complete enrichment also mean that the data are not valid for the general patient population.

Whether the findings of experimental pain studies are relevant to the clinical experience of pain is a matter of debate. Experimental models that use acute stimuli may activate the nervous system in different ways compared with pain generated from ongoing inflammation, as in patients. However, correlation between analgesic effect on clinical pain and experimental pain has been consistently reported (Poitras et al., 2002). Certainly, experimental studies of pain create important hypotheses

that, if possible, should be tested in more traditional clinical studies. However, this is not always possible because of the many confounders in clinical studies and the limitation in finding large homogenous patient groups to test in a more traditional way.

The application of experimental pain in healthy volunteers as well as in patients may bridge the knowledge obtained from animal studies to clinical studies, making experimental studies an important tool in translational pain research. To improve pain treatment, it is important to study the underlying physiological mechanisms of pain in different patient groups as well as the underlying pharmacological mechanism of actions of analgesics. One aim of such research is that clinicians may be better equipped to choose the optimal analgesic and dose or to make informed decisions regarding analgesic rotation strategies in efforts to achieve the best individual patient outcomes. To explain clinical behavior it may also be possible to use specific drugs as a diagnostic test to guide therapy, using a mechanism-based diagnosis based on drug effects (Gottrup et al., 2006). In summary, several factors need to be considered when planning an experimental human pain study to evaluate analgesic effect, given in Table 6.

A. Conclusion

Assessing analgesic effect by experimental pain models in healthy volunteers and patients may contribute to mechanism-based classification of pain and thereby to a better understanding of the underlying symptoms. The methods can be used in testing new and existing analgesics and have a major impact in the development process of potential new analgesics as well as in decision-making, such as indications and dosing. This may affect the ability of clinicians to predict patient responses to analgesics in efforts to individualize optimal analgesic therapy.

B. Perspectives

Selection of methods and experimental design is highly variable across countries and researchers. Standardization of experimental pain models across laboratories may increase their reliability and validity and allow comparison of findings. Responses to different experimental pain modalities represent different specific dimensions (Neziri et al., 2011), and therefore a battery of experiments shall be selected with proper selection of the optimal tests (i.e., on the basis of the data in this review) together with statistical considerations regarding multiple comparisons. Many of these complicated methods are manufactured locally and are available only in the most advanced laboratories, but possibilities for acquiring commercially developed equipment has improved in recent years. Collaboration between researchers such as that recently established in the German Research Network on Neuropathic Pain (Rolke et al., 2006) may also be helpful in establishing databases for

quantitative sensory testing and may be used to infer underlying mechanisms from somatosensory phenotypes in drug evaluation. Finally, combination of sensory testing with neurophysiological and imaging as-

TABLE 6

Factors to consider when planning an experimental human pain study

Topic and Recommendations
Pharmacokinetics Design experiment according to pharmacokinetic profile. If possible, select drugs with specific and potent analgesic effect especially if models only permit less intense pain intensity. Select appropriate (and preferable relative high) dose. Use dose-response regimens when possible.
Stimulations Select models with optimal control of stimulus intensities. Use models with large dynamic range. Use models evoking peripheral and central pain mechanisms (e.g., single and repeated electrical stimulation) where appropriate. Consider multimodal tests that are advantageous in many experimental conditions. In selected cases use multitissue stimulations. Design protocol with stimulations at appropriate time according to pharmacokinetics. Select deep stimuli whenever possible to mimic the clinical situation. Use tonic rather than phasic stimulation to evaluate pain intensity. When feasible, add models evoking allodynia and hyperalgesia to mimic clinical pain. Use suprathreshold pain stimuli especially in evaluation of weak analgesics. Select the stimulus paradigms according to known drug mechanisms (e.g., summated stimuli in evaluation of NMDA antagonists). Consider selecting stimulus according to known pain mechanisms (e.g., projection of referred pain in functional diseases). Use models with activation predominantly of C fibers. Apply "methods of limits" if possible. Only models tested for reliability should be selected. Prefer models with high internal validity (i.e., most sensitive for analgesics in the painful range of sensations). Prefer models with high external validity (i.e., mimics clinical pain and drug mechanisms). Consider arousal status of the subjects (avoid prolonged experiments without breaks).
Assessments Use both subjective and objective pain assessments if feasible. Select reliable psychophysical scales. In selected cases, use more qualitative pain assessments (e.g., McGill Pain Questionnaire). Select explanatory neurophysiologic or imaging methods if feasible. Use predefined and robust output parameters. In selected cases, use supplementary assessments (e.g., referred pain areas).
Subjects In design, re-evaluate ethical considerations. Consider selection of subjects using psychological evaluation. Consider enriched enrollment (i.e., evaluate sensitivity to the tests or drugs). Select appropriate sample (volunteers/patient groups). Consider selection according to gender, age, genotype, etc. Reduce anxiety through screening, pretesting and proper instruction. Train subjects in pain ratings to increase reliability.
Laboratory Use well educated and experienced staff trained in the tests. Use same person to perform tests for repeated assessments. Pay attention to theoretical and practical education of staff. Ensure recommendations for good clinical and laboratory practice are followed. Avoid any interruption and disturbing factors during experiments. Isolate equipment between experiments to ensure stability (mainly for advanced electronic equipment). Reconsider safety issues whenever necessary.
Data analysis Evaluate according to predefined primary and secondary endpoints. Use statistical adjustment for multiple comparisons. Perform baseline corrections in repeated testing. Use expert evaluation of neurophysiological/imaging data.

assessment, genetic profiling, and pharmacokinetic and pharmacodynamic considerations together with advanced statistical modeling such as adapted medical decision systems may in the future pave the road for optimized development of analgesics and stratified medicine with the goal to tailor individualized medicine.

Acknowledgments

Philippe Petitdejan from Aalborg Hospital is acknowledged for assisting in graphic layout of figures.

Authorship Contributions

Wrote or contributed to the writing of the manuscript: Olesen, Andresen, Staahl, and Drewes.

References

- Alstergren P, Ernberg M, Nilsson M, Hajati AK, Sessle BJ, and Kopp S (2010) Glutamate-induced temporomandibular joint pain in healthy individuals is partially mediated by peripheral NMDA receptors. *J Orofac Pain* **24**:172–180.
- Altis K, Schmidtko A, Angioni C, Kuczka K, Schmidt H, Geisslinger G, Lötsch J, and Tegeder I (2009) Analgesic efficacy of tramadol, pregabalin and ibuprofen in menthol-evoked cold hyperalgesia. *Pain* **147**:116–121.
- Andersen H, Arendt-Nielsen L, Svensson P, Danneskiold-Samsøe B, and Graven-Nielsen T (2008) Spatial and temporal aspects of muscle hyperalgesia induced by nerve growth factor in humans. *Exp Brain Res* **191**:371–382.
- Andersen OK, Felsby S, Nicolaisen L, Bjerring P, Jensen TS, and Arendt-Nielsen L (1996) The effect of Ketamine on stimulation of primary and secondary hyperalgesic areas induced by capsaicin—a double-blind, placebo-controlled, human experimental study. *Pain* **66**:51–62.
- Andersen OK, Mørch CD, and Arendt-Nielsen L (2006) Modulation of heat evoked nociceptive withdrawal reflexes by painful intramuscular conditioning stimulation. *Exp Brain Res* **174**:775–780.
- Andresen T, Staahl C, Oksche A, Mansikka H, Arendt-Nielsen L, and Drewes AM (2010) Effect of transdermal opioids in experimentally induced superficial, deep and hyperalgesic pain. *Br J Pharmacol* **164**:934–945.
- Angst MS, Ramaswamy B, Davies MF, and Maze M (2004) Comparative analgesic and mental effects of increasing plasma concentrations of dexmedetomidine and alfentanil in humans. *Anesthesiology* **101**:744–752.
- Apkarian AV, Baliki MN, and Geha PY (2009) Towards a theory of chronic pain. *Prog Neurobiol* **87**:81–97.
- Arendt-Nielsen L, Bjerring P, and Dahl JB (1991a) A quantitative double-blind evaluation of the antinociceptive effects of perineurally administered morphine compared with lidocaine. *Acta Anaesthesiol Scand* **35**:24–29.
- Arendt-Nielsen L, Curatolo M, and Drewes A (2007a) Human experimental pain models in drug development: translational pain research. *Curr Opin Investig Drugs* **8**:41–53.
- Arendt-Nielsen L, Drewes AM, Hansen JB, and Tage-Jensen U (1997) Gut pain reactions in man: an experimental investigation using short and long duration transcutaneous electrical stimulation. *Pain* **69**:255–262.
- Arendt-Nielsen L, Drewes AM, Svendsen L, and Brennum J (1994) Quantitative assessment of joint pain following treatment of rheumatoid arthritis with ibuprofen cream. *Scand J Rheumatol* **23**:334–337.
- Arendt-Nielsen L, Frøkjær JB, Staahl C, Graven-Nielsen T, Huggins JP, Smart TS, and Drewes AM (2007b) Effects of gabapentin on experimental somatic pain and temporal summation. *Reg Anesth Pain Med* **32**:382–388.
- Arendt-Nielsen L and Gotlibsen K (1992) Segmental inhibition of laser-evoked brain potentials by ipsi- and contralaterally applied cold pressor pain. *Eur J Appl Physiol Occup Physiol* **64**:56–61.
- Arendt-Nielsen L, Laursen RJ, and Drewes AM (2000a) Referred pain as an indicator for neural plasticity. *Prog Brain Res* **129**:343–356.
- Arendt-Nielsen L, Mansikka H, Staahl C, Rees H, Tan K, Smart TS, Monhemius R, Suzuki R, and Drewes AM (2011) A translational study of the effects of ketamine and pregabalin on temporal summation of experimental pain. *Reg Anesth Pain Med* **36**:585–591.
- Arendt-Nielsen L, Nielsen J, Petersen-Felix S, Schneider TW, and Zbinden AM (1996) Effect of racemic mixture and the (S+)-isomer of ketamine on temporal and spatial summation of pain. *Br J Anaesth* **77**:625–631.
- Arendt-Nielsen L, Oberg B, and Bjerring P (1991b) Hypoalgesia following epidural morphine: a controlled quantitative experimental study. *Acta Anaesthesiol Scand* **35**:430–435.
- Arendt-Nielsen L, Olesen AE, Staahl C, Menzaghi F, Kell S, Wong GY, and Drewes AM (2009) Analgesic efficacy of peripheral kappa opioid receptor agonist CR665 compared to oxycodone in a multi-modal, multi-tissue experimental human pain model: selective effect on visceral pain. *Anesthesiology* **111**:616–624.
- Arendt-Nielsen L, Pedersen P, Poulsen L, Andersen OK, Bjerring P, Coste I, Insausti J, Sindrup SH, and Drewes AM (2000b) A 5-HT antagonist (UP 26-91) versus codeine and placebo in a human experimental pain study. *Pain Res Manag* **4**:135–140.
- Arendt-Nielsen L, Petersen-Felix S, Fischer M, Bak P, Bjerring P, and Zbinden AM (1995) The effect of N-methyl-D-aspartate antagonist (ketamine) on single and repeated nociceptive stimuli: a placebo-controlled experimental human study. *Anesth Analg* **81**:63–68.
- Arendt-Nielsen L, Sonnenborg FA, and Andersen OK (2000c) Facilitation of the withdrawal reflex by repeated transcutaneous electrical stimulation: an experimental study on central integration in humans. *Eur J Appl Physiol* **81**:165–173.
- Arendt-Nielsen L, Svensson P, Sessle BJ, Cairns BE, and Wang K (2008) Interactions between glutamate and capsaicin in inducing muscle pain and sensitization in humans. *Eur J Pain* **12**:661–670.
- Arendt-Nielsen L and Yarnitsky D (2009) Experimental and clinical applications of quantitative sensory testing applied to skin, muscles and viscera. *J Pain* **10**:556–572.
- Aurilio C, Pota V, Pace MC, Passavanti MB, and Barbarisi M (2008) Ionic channels and neuropathic pain: physiopathology and applications. *J Cell Physiol* **215**:8–14.
- Ayesh EE, Jensen TS, and Svensson P (2008) Effects of intra-articular ketamine on pain and somatosensory function in temporomandibular joint arthralgia patients. *Pain* **137**:286–294.
- Aykanat V, Gentgall M, Briggs N, Williams D, Yap S, and Rolan P (2012) Intradermal capsaicin as a neuropathic pain model in patients with unilateral sciatica. *Br J Clin Pharmacol* **73**:37–45.
- Ayles S, Graven-Nielsen T, and Gibson W (2011) Vibration-induced afferent activity augments delayed onset muscle allodynia. *J Pain* **12**:884–891.
- Babenko V, Graven-Nielsen T, Svensson P, Drewes AM, Jensen TS, and Arendt-Nielsen L (1999a) Experimental human muscle pain and muscular hyperalgesia induced by combinations of serotonin and bradykinin. *Pain* **82**:1–8.
- Babenko V, Graven-Nielsen T, Svensson P, Drewes AM, Jensen TS, and Arendt-Nielsen L (1999b) Experimental human muscle pain induced by intramuscular injections of bradykinin, serotonin, and substance P. *Eur J Pain* **3**:93–102.
- Bandschapp O, Flitz J, Urwyler A, Koppert W, and Ruppen W (2011) Tropisetron blocks analgesic action of acetaminophen: a human pain model study. *Pain* **152**:1304–1310.
- Banoub M, Tetzlaff JE, and Schubert A (2003) Pharmacologic and physiologic influences affecting sensory evoked potentials: implications for perioperative monitoring. *Anesthesiology* **99**:716–737.
- Barlas P, Craig JA, Robinson J, Walsh DM, Baxter GD, and Allen JM (2000) Managing delayed-onset muscle soreness: lack of effect of selected oral systemic analgesics. *Arch Phys Med Rehabil* **81**:966–972.
- Bauer CS, Rahman W, Tran-van-Minh A, Lujan R, Dickenson AH, and Dolphin AC (2010) The anti-allodynic alpha(2)delta ligand pregabalin inhibits the trafficking of the calcium channel alpha(2)delta-1 subunit to presynaptic terminals in vivo. *Biochem Soc Trans* **38**:525–528.
- Bear MF and Malenka RC (1994) Synaptic plasticity: LTP and LTD. *Curr Opin Neurobiol* **4**:389–399.
- Bendixen KH, Baad-Hansen L, Cairns BE, and Svensson P (2010) Effects of low-dose intramuscular ketorolac on experimental pain in the masseter muscle of healthy women. *J Orofac Pain* **24**:398–407.
- Bendtsen L and Jensen R (2000) Amitriptyline reduces myofascial tenderness in patients with chronic tension-type headache. *Cephalalgia* **20**:603–610.
- Benedetti F, Pollo A, Lopiano L, Lanotte M, Vighetti S, and Rainero I (2003) Conscious expectation and unconscious conditioning in analgesic, motor, and hormonal placebo/nocebo responses. *J Neurosci* **23**:4315–4323.
- Berge OG (2011) Predictive validity of behavioral animal models for chronic pain. *Br J Pharmacol* **164**:1195–1206.
- Bergström M, Hargreaves RJ, Burns HD, Goldberg MR, Sciberras D, Reines SA, Petty KJ, Ogren M, Antoni G, Långström B, et al. (2004) Human positron emission tomography studies of brain neurokinin 1 receptor occupancy by aprepitant. *Biol Psychiatry* **55**:1007–1012.
- Bickel A, Dorfs S, Schmelz M, Forster C, Uhl W, and Handwerker HO (1998) Effects of antihyperalgesic drugs on experimentally induced hyperalgesia in man. *Pain* **76**:317–325.
- Binder A, Stengel M, Klebe O, Wasner G, and Baron R (2011) Topical high-concentration (40%) menthol-somatosensory profile of a human surrogate pain model. *J Pain* **12**:764–773.
- Bishop T, Ballard A, Holmes H, Young AR, and McMahon SB (2009) Ultraviolet-B induced inflammation of human skin: characterisation and comparison with traditional models of hyperalgesia. *Eur J Pain* **13**:524–532.
- Björdal JM, Ljunggren AE, Klovning A, and Slørdal L (2004) Non-steroidal anti-inflammatory drugs, including cyclo-oxygenase-2 inhibitors, in osteoarthritic knee pain: meta-analysis of randomised placebo controlled trials. *BMJ* **329**:1317.
- Black ML, Hill JL, and Zaeny JP (1999) Behavioral and physiological effects of remifentanyl and alfentanil in healthy volunteers. *Anesthesiology* **90**:718–726.
- Blasco T and Bayés R (1988) Unreliability of the Cold Pressor Test Method in pain studies. *Methods Find Exp Clin Pharmacol* **10**:767–772.
- Bonica JJ and Loeser JD (2001) Applied anatomy relevant to pain, in *Bonica's Management of Pain* (Loeser JD ed) pp 196–221, Lippincott Williams & Wilkins, Philadelphia.
- Borsook D, Becerra L, and Hargreaves R (2011) Biomarkers for chronic pain and analgesia. Part 2: how, where, and what to look for using functional imaging. *Discov Med* **11**:209–219.
- Borsook D and Becerra LR (2006) Breaking down the barriers: fMRI applications in pain, analgesia and analgesics. *Mol Pain* **2**:30.
- Bouhassira D, Chitour D, Villanueva L, and Le Bars D (1993) Morphine and diffuse noxious inhibitory controls in the rat: effects of lesions of the rostral ventromedial medulla. *Eur J Pharmacol* **232**:207–215.
- Bouhassira D, Kern D, Rouaud J, Pelle-Lancien E, and Morain F (2005) Investigation of the paradoxical painful sensation ('illusion of pain') produced by a thermal grill. *Pain* **114**:160–167.
- Bouwense SA, Buscher HC, van Goor H, and Wilder-Smith OH (2011) S-ketamine modulates hyperalgesia in patients with chronic pancreatitis pain. *Reg Anesth Pain Med* **36**:303–307.
- Brennum J, Arendt-Nielsen L, Horn A, Secher NH, and Jensen TS (1993) Quantitative sensory examination during epidural anaesthesia and analgesia in man: effects of morphine. *Pain* **52**:75–83.
- Brennum J, Arendt-Nielsen L, Secher NH, Jensen TS, and Bjerring P (1992) Quan-

- titative sensory examination in human epidural anaesthesia and analgesia: effects of lidocaine. *Pain* **51**:27–34.
- Brock C, Andresen T, Frøkjær JB, Gale J, Olesen AE, Arendt-Nielsen L, and Drewes AM (2009a) Central pain mechanisms following combined acid and capsaicin perfusion of the human oesophagus. *Eur J Pain* **14**:273–281.
- Brock C, Arendt-Nielsen L, Wilder-Smith O, and Drewes AM (2009b) Sensory testing of the human gastrointestinal tract. *World J Gastroenterol* **15**:151–159.
- Brock C, Nissen TD, Gravesen FH, Frøkjær JB, Omar H, Gale J, Gregersen H, Svendsen O, and Drewes AM (2008) Multimodal sensory testing of the rectum and rectosigmoid: development and reproducibility of a new method. *Neurogastroenterol Motil* **20**:908–918.
- Brock C, Olesen SS, Valeriani M, Arendt-Nielsen L, and Drewes AM (2012) Brain activity in rectosigmoid pain: unravelling conditioning pain modulatory pathways. *Clin Neurophysiol* **123**:829–837.
- Bromm B, Forth W, Richter E, and Scharein E (1992) Effects of acetaminophen and antipyrine on non-inflammatory pain and EEG activity. *Pain* **50**:213–221.
- Bromm B, Ganzel R, Herrmann WM, Meier W, and Scharein E (1986a) Pentazocine and flupirtine effects on spontaneous and evoked EEG activity. *Neuropsychobiology* **16**:152–156.
- Bromm B, Meier W, and Scharein E (1986b) Imipramine reduces experimental pain. *Pain* **25**:245–257.
- Bromm B, Rundshagen I, and Scharein E (1991) Central analgesic effects of acetylsalicylic acid in healthy men. *Arzneimittelforschung* **41**:1123–1129.
- Bromm B and Treede RD (1991) Laser-evoked cerebral potentials in the assessment of cutaneous pain sensitivity in normal subjects and patients. *Rev Neurol* **147**: 625–643.
- Byers MR and Bonica JJ (2001) Peripheral pain mechanisms and nociceptor plasticity, in *Bonica's Management of Pain* (Loeser LD, Butler SH, Chapman CR and Turk DC eds) 3rd ed, pp 26–73 Lippincott Williams & Wilkins, Philadelphia.
- Cairns BE (2008) Physiological Properties of Thin-Fiber Muscle Afferents: Excitation and Modulatory Effects, in *Fundamentals of musculoskeletal pain* (Graven-Nielsen T, Arendt-Nielsen L and Mense S eds) pp 19–32, IASP Press, Seattle.
- Cairns BE, Hu JW, Arendt-Nielsen L, Sessle BJ, and Svensson P (2001) Sex-related differences in human pain and rat afferent discharge evoked by injection of glutamate into the masseter muscle. *J Neurophysiol* **86**:782–791.
- Cairns BE, Svensson P, Wang K, Castrillon E, Hupfeld S, Sessle BJ, and Arendt-Nielsen L (2006) Ketamine attenuates glutamate-induced mechanical sensitization of the masseter muscle in human males. *Exp Brain Res* **169**:467–472.
- Campbell CM, France CR, Robinson ME, Logan HL, Geffken GR, and Fillingim RB (2008) Ethnic differences in diffuse noxious inhibitory controls. *J Pain* **9**:759–766.
- Cannon RO 3rd, Quyyumi AA, Mincemoyer R, Stine AM, Gracely RH, Smith WB, Geraci MF, Black BC, Uhde TW, and Waclawiw MA (1994) Imipramine in patients with chest pain despite normal coronary angiograms. *N Engl J Med* **330**:1411–1417.
- Caraceni A, Cherny N, Fainsinger R, Kaasa S, Poulain P, Radbruch L, and De Conno F (2002) Pain measurement tools and methods in clinical research in palliative care: recommendations of an Expert Working Group of the European Association of Palliative Care. *J Pain Symptom Manage* **23**:239–255.
- Carlton SM and Coggeshall RE (1999) Inflammation-induced changes in peripheral glutamate receptor populations. *Brain Res* **820**:63–70.
- Carnes PL, Cook B, Eleazer PD, and Scheetz JP (1998) Change in pain threshold by mepiperidine, naproxen sodium, and acetaminophen as determined by electric pulp testing. *Anesth Prog* **45**:139–142.
- Cervero F (2000) Visceral pain-central sensitization. *Gut* **47** (Suppl 4):iv56–iv57.
- Cervero F (1994) Sensory innervation of the viscera: peripheral basis of visceral pain. *Physiol Rev* **74**:95–138.
- Chapman CR, Hill HF, Saeger L, and Gavrin J (1990) Profiles of opioid analgesia in humans after intravenous bolus administration: alfentanil, fentanyl and morphine compared on experimental pain. *Pain* **43**:47–55.
- Chassaing C, Schmidt J, Eschalier A, Cardot JM, and Dubray C (2006) Hyperalgesia induced by cutaneous freeze injury for testing analgesics in healthy volunteers. *Br J Clin Pharmacol* **61**:389–397.
- Chen Y, Wang DJ, and Detre JA (2011) Test-retest reliability of arterial spin labeling with common labeling strategies. *J Magn Reson Imaging* **33**:940–949.
- Cheung K, Hume P, and Maxwell L (2003) Delayed onset muscle soreness: treatment strategies and performance factors. *Sports Med* **33**:145–164.
- Chizh BA, Göhring M, Tröster A, Quartey GK, Schmelz M, and Koppert W (2007) Effects of oral pregabalin and amitriptyline on pain and central sensitization in the electrical hyperalgesia model in human volunteers. *Br J Anaesth* **98**:246–254.
- Chizh BA, Priestley T, Rowbotham M, and Schaffler K (2009) Predicting therapeutic efficacy - experimental pain in human subjects. *Brain Res Rev* **60**:243–254.
- Coderre TJ, Katz J, Vaccarino AL, and Melzack R (1993) Contribution of central neuroplasticity to pathological pain: review of clinical and experimental evidence. *Pain* **52**:259–285.
- Coghill RC, McHaffie JG, and Yen YF (2003) Neural correlates of interindividual differences in the subjective experience of pain. *Proc Natl Acad Sci USA* **100**:8538–8542.
- Compton P, Charuvastra VC, and Ling W (2003) Effect of oral ketorolac and gender on human cold pressor pain tolerance. *Clin Exp Pharmacol Physiol* **30**:759–763.
- Craig AD (2003) Pain mechanisms: labeled lines versus convergence in central processing. *Annu Rev Neurosci* **26**:1–30.
- Craig AD and Bushnell MC (1994) The thermal grill illusion: unmasking the burn of cold pain. *Science* **265**:252–255.
- Cruccu G, Bini G, Accornero N, Berardelli A, and Manfredi M (1982) Analgesic activity of carprofen on human experimental dental pain. *Arzneimittelforschung* **32**:1146–1149.
- Curatolo M, Arendt-Nielsen L, and Petersen-Felix S (2006) Central hypersensitivity in chronic pain: mechanisms and clinical implications. *Phys Med Rehabil Clin N Am* **17**:287–302.
- Curatolo M, Petersen-Felix S, and Arendt-Nielsen L (2000a) Sensory assessment of regional analgesia in humans: a review of methods and applications. *Anesthesiology* **93**:1517–1530.
- Curatolo M, Petersen-Felix S, Gerber A, and Arendt-Nielsen L (2000b) Remifentanyl inhibits muscular more than cutaneous pain in humans. *Br J Anaesth* **85**:529–532.
- De Schepper HU, Cremonini F, Park MI, and Camilleri M (2004) Opioids and the gut: pharmacology and current clinical experience. *Neurogastroenterol Motil* **16**: 383–394.
- de Tommaso M, Shevel E, Pecoraro C, Sardaro M, Divenere D, Di Fruscolo O, Lamberti P, and Livrea P (2006) Intra-oral orthosis vs amitriptyline in chronic tension-type headache: a clinical and laser evoked potentials study. *Head Face Med* **2**:15.
- Defrin R, Benstein-Sheraizin A, Bezalel A, Mantzur O, and Arendt-Nielsen L (2008) The spatial characteristics of the painful thermal grill illusion. *Pain* **138**:577–586.
- deGroot J, Zhou S, and Carlton SM (2000) Peripheral glutamate release in the hindpaw following low and high intensity sciatic stimulation. *Neuroreport* **11**:497–502.
- Delvaux M, Beck A, Jacob J, Bouzamon H, Weber FT, and Frexinos J (2004) Effect of asimadoline, a kappa opioid agonist, on pain induced by colonic distension in patients with irritable bowel syndrome. *Aliment Pharmacol Ther* **20**:237–246.
- Delvaux M, Louvel D, Lagier E, Scherrer B, Abitbol JL, and Frexinos J (1999) The kappa agonist fedotozine relieves hypersensitivity to colonic distention in patients with irritable bowel syndrome. *Gastroenterology* **116**:38–45.
- Delvaux M, Louvel D, Mamet JP, Campos-Oriola R, and Frexinos J (1998) Effect of alosetron on responses to colonic distension in patients with irritable bowel syndrome. *Aliment Pharmacol Ther* **12**:849–855.
- D'Honneur G, Gilton A, Sandouk P, Scherrmann JM, and Duvaldestin P (1994) Plasma and cerebrospinal fluid concentrations of morphine and morphine glucuronides after oral morphine. The influence of renal failure. *Anesthesiology* **81**:87–93.
- Dickenson AH (1995) Spinal cord pharmacology of pain. *Br J Anaesth* **75**:193–200.
- Dirks J, Petersen KL, and Dahl JB (2003) The heat/capsaicin sensitization model: a methodologic study. *J Pain* **4**:122–128.
- Dirks J, Petersen KL, Rowbotham MC, and Dahl JB (2002) Gabapentin suppresses cutaneous hyperalgesia following heat-capsaicin sensitization. *Anesthesiology* **97**: 102–107.
- D'Mello R and Dickenson AH (2008) Spinal cord mechanisms of pain. *Br J Anaesth* **101**:8–16.
- Dolgin E (2010) Animalgesic effects. *Nat Med* **16**:1237–1240.
- Drewes AM and Gregersen H (2006) Multimodal pain stimulation of the gastrointestinal tract. *World J Gastroenterol* **12**:2477–2486.
- Drewes AM, Gregersen H, and Arendt-Nielsen L (2003) Experimental pain in gastroenterology: a reappraisal of human studies. *Scand J Gastroenterol* **38**:1115–1130.
- Drewes AM, Helweg-Larsen S, Petersen P, Brennum J, Andreasen A, Poulsen LH, and Jensen TS (1993) McGill Pain Questionnaire translated into Danish: experimental and clinical findings. *Clin J Pain* **9**:80–87.
- Drewes AM, Krarup AL, Detlefsen S, Malmstrøm ML, Dimcevski G, and Funch-Jensen P (2008) Pain in chronic pancreatitis: the role of neuropathic pain mechanisms. *Gut* **57**:1616–1627.
- Drewes AM, Pedersen J, Liu W, Arendt-Nielsen L, and Gregersen H (2003) Controlled mechanical distension of the human oesophagus: sensory and biomechanical findings. *Scand J Gastroenterol* **38**:27–35.
- Drewes AM, Reddy H, Staahl C, Pedersen J, Funch-Jensen P, Arendt-Nielsen L, and Gregersen H (2005) Sensory-motor responses to mechanical stimulation of the esophagus after sensitization with acid. *World J Gastroenterol* **11**:4367–4374.
- Drewes AM, Schipper KP, Dimcevski G, Petersen P, Andersen OK, Gregersen H, and Arendt-Nielsen L (2003a) Multi-modal induction and assessment of allodynia and hyperalgesia in the human oesophagus. *Eur J Pain* **7**:539–549.
- Drewes AM, Schipper KP, Dimcevski G, Petersen P, Gregersen H, Funch-Jensen P, and Arendt-Nielsen L (2003b) Gut pain and hyperalgesia induced by capsaicin: a human experimental model. *Pain* **104**:333–341.
- Dusch M, Namer B, Strupf M, Schleya M, Rukwieda R, Hägglöf B, Schmelz M, and Koppert W (2010) Cross-over evaluation of electrically induced pain and hyperalgesia. *Scand J Pain* **1**:205–210.
- Dyck PJ, Peroutka S, Rask C, Burton E, Baker MK, Lehman KA, Gillen DA, Hokanson JL, and O'Brien PC (1997) Intradermal recombinant human nerve growth factor induces pressure allodynia and lowered heat-pain threshold in humans. *Neurology* **48**:501–505.
- Eckhardt K, Ammon S, Hofmann U, Riebe A, Gugeler N, and Mikus G (2000) Gabapentin enhances the analgesic effect of morphine in healthy volunteers. *Anesth Analg* **91**:185–191.
- Edwards RR, Ness TJ, and Fillingim RB (2004) Endogenous opioids, blood pressure, and diffuse noxious inhibitory controls: a preliminary study. *Percept Mot Skills* **99**:679–687.
- Edwards RR, Sarlani E, Wesselmann U, and Fillingim RB (2005) Quantitative assessment of experimental pain perception: multiple domains of clinical relevance. *Pain* **114**:315–319.
- Eide K, Stubhaug A, Oye I, and Breivik H (1995) Continuous subcutaneous administration of the N-methyl-D-aspartic acid (NMDA) receptor antagonist ketamine in the treatment of post-herpetic neuralgia. *Pain* **61**:221–228.
- Eide PK, Jørum E, Stubhaug A, Bremnes J, and Breivik H (1994) Relief of post-herpetic neuralgia with the N-methyl-D-aspartic acid receptor antagonist ketamine: a double-blind, cross-over comparison with morphine and placebo. *Pain* **58**:347–354.
- Eisenach JC, Curry R, Tong C, Houle TT, and Yaksh TL (2010) Effects of intrathecal ketorolac on human experimental pain. *Anesthesiology* **112**:1216–1224.
- Eisenach JC, Hood DD, Curry R, and Tong C (1997) Alfentanil, but not amitriptyline, reduces pain, hyperalgesia, and allodynia from intradermal injection of capsaicin in humans. *Anesthesiology* **86**:1279–1287.
- Enggaard TP, Poulsen L, Arendt-Nielsen L, Brøsen K, Ossig J, and Sindrup SH

- (2006) The analgesic effect of tramadol after intravenous injection in healthy volunteers in relation to CYP2D6. *Anesth Analg* **102**:146–150.
- Enggaard TP, Poulsen L, Arendt-Nielsen L, Hansen SH, Bjørnsdottir I, Gram LF, and Sindrup SH (2001) The analgesic effect of codeine as compared to imipramine in different human experimental pain models. *Pain* **92**:277–282.
- Ernberg M, Lundeberg T, and Kopp S (2003) Effects on muscle pain by intramuscular injection of granisetron in patients with fibromyalgia. *Pain* **101**:275–282.
- Everaerts W, Gees M, Alpizar YA, Farre R, Leten C, Apetrei A, Dewachter I, van Leuven F, Vennekens R, De Ridder D, et al. (2011) The capsaicin receptor TRPV1 is a crucial mediator of the noxious effects of mustard oil. *Curr Biol* **21**:316–321.
- Field MJ, Cox PJ, Stott E, Melrose H, Offord J, Su TZ, Bramwell S, Corradini L, England S, Winks J, et al. (2006) Identification of the alpha2-delta-1 subunit of voltage-dependent calcium channels as a molecular target for pain mediating the analgesic actions of pregabalin. *Proc Natl Acad Sci USA* **103**:17537–17542.
- Fields HL, Basbaum AI and Heinricher MM (2006) Central nervous system mechanisms of pain modulation, in *Textbook of Pain* (McMahon SB and Koltzenburg M eds) pp 125–142. Elsevier Churchill Livingstone, London.
- Filitz J, Ihmsen H, Günther W, Tröster A, Schwilden H, Schüttler J, and Koppert W (2008) Supra-additive effects of tramadol and acetaminophen in a human pain model. *Pain* **136**:262–270.
- Fillingim RB, Hastie BA, Ness TJ, Glover TL, Campbell CM, and Staud R (2005a) Sex-related psychological predictors of baseline pain perception and analgesic responses to pentazocine. *Biol Psychol* **69**:97–112.
- Fillingim RB, Ness TJ, Glover TL, Campbell CM, Hastie BA, Price DD, and Staud R (2005b) Morphine responses and experimental pain: sex differences in side effects and cardiovascular responses but not analgesia. *J Pain* **6**:116–124.
- Fillingim RB, Ness TJ, Glover TL, Campbell CM, Price DD, and Staud R (2004) Experimental pain models reveal no sex differences in pentazocine analgesia in humans. *Anesthesiology* **100**:1263–1270.
- Finochietti S, Andresen T, Arendt-Nielsen L, and Graven-Nielsen T (2012) Pain evoked by pressure stimulation on the tibia bone—influence of probe diameter on tissue stress and strain. *Eur J Pain* **16**:534–542.
- Finochietti S, Nielsen M, Mørch CD, Arendt-Nielsen L, and Graven-Nielsen T (2011) Pressure-induced muscle pain and tissue biomechanics: a computational and experimental study. *Eur J Pain* **15**:36–44.
- Fioravanti B and Vanderah TW (2008) The ORL-1 receptor system: are there opportunities for antagonists in pain therapy? *Curr Top Med Chem* **8**:1442–1451.
- Fischer AA (1998) Muscle pain syndromes and fibromyalgia. Pressure algometry for quantification of diagnosis and treatment outcome. Haworth Medical Press, New York.
- Forster C, Anton F, Reeh PW, Weber E, and Handwerker HO (1988) Measurement of the analgesic effects of aspirin with a new experimental algometric procedure. *Pain* **32**:215–222.
- Fowler CJ, Sitzoglu K, Ali Z, and Halonen P (1988) The conduction velocities of peripheral nerve fibres conveying sensations of warming and cooling. *J Neurol Neurosurg Psychiatry* **51**:1164–1170.
- Frahm KS, Andersen OK, Arendt-Nielsen L, and Mørch CD (2010) Spatial temperature distribution in human hairy and glabrous skin after infrared CO₂ laser radiation. *Biomed Eng Online* **9**:69.
- Fraitag B, Homerin M, and Hecketsweiler P (1994) Double-blind dose-response multicenter comparison of fedotzine and placebo in treatment of nonulcer dyspepsia. *Dig Dis Sci* **39**:1072–1077.
- Frampton CL and Hughes-Webb P (2011) The measurement of pain. *Clin Oncol (R Coll Radiol)* **23**:381–386.
- Frey Law LA, Sluka KA, McMullen T, Lee J, Arendt-Nielsen L, and Graven-Nielsen T (2008) Acidic buffer induced muscle pain evokes referred pain and mechanical hyperalgesia in humans. *Pain* **140**:254–264.
- Frøkjær JB, Andersen SD, Gale J, Arendt-Nielsen L, Gregersen H, and Drewes AM (2005) An experimental study of viscerovisceral hyperalgesia using an ultrasound-based multimodal sensory testing approach. *Pain* **119**:191–200.
- Frøkjær JB, Olesen SS, Graversen C, Andresen T, Lelic D and Drewes AM (2011) Neuroimaging of the human visceral pain system—a methodological review. *Scand J Pain* **2**:95–104.
- Gazerani P, Wang K, Cairns BE, Svensson P, and Arendt-Nielsen L (2006) Effects of subcutaneous administration of glutamate on pain, sensitization and vasomotor responses in healthy men and women. *Pain* **124**:338–348.
- Gear RW, Miaskowski C, Gordon NC, Paul SM, Heller PH, and Levine JD (1996) Kappa-opioids produce significantly greater analgesia in women than in men. *Nat Med* **2**:1248–1250.
- Gerber RK, Nie H, Arendt-Nielsen L, Curatolo M, and Graven-Nielsen T (2011) Local pain and spreading hyperalgesia induced by intramuscular injection of nerve growth factor are not reduced by local anesthesia of the muscle. *Clin J Pain* **27**:240–247.
- Ghaith O, El-Halabi M, Hashash JG, and Sharara AI (2010) Investigational agents for the irritable bowel syndrome. *Expert Opin Investig Drugs* **19**:1161–1178.
- Gibson W, Arendt-Nielsen L, and Graven-Nielsen T (2006) Referred pain and hyperalgesia in human tendon and muscle belly tissue. *Pain* **120**:113–123.
- Gillen C, Haurand M, Kobelt DJ, and Wnendt S (2000) Affinity, potency and efficacy of tramadol and its metabolites at the cloned human mu-opioid receptor. *Naunyn-Schmiedeberg's Arch Pharmacol* **362**:116–121.
- Ginosar Y, Riley ET, and Angst MS (2003) The site of action of epidural fentanyl in humans: the difference between infusion and bolus administration. *Anesth Analg* **97**:1428–1438.
- Giordano J, Abramson K, and Boswell MV (2010) Pain assessment: subjectivity, objectivity, and the use of neurotechnology. *Pain Physician* **13**:305–315.
- Göbel H, Hamouz V, Hansen C, Heiningner K, Hirsch S, Lindner V, Heuss D, and Soyka D (1994) Chronic tension-type headache: amitriptyline reduces clinical headache-duration and experimental pain sensitivity but does not alter pericranial muscle activity readings. *Pain* **59**:241–249.
- Gottrup H, Bach FW, Arendt-Nielsen L, and Jensen TS (2000a) Peripheral lidocaine but not ketamine inhibits capsaicin-induced hyperalgesia in humans. *Br J Anaesth* **85**:520–528.
- Gottrup H, Bach FW, Juhl G, and Jensen TS (2006) Differential effect of ketamine and lidocaine on spontaneous and mechanical evoked pain in patients with nerve injury pain. *Anesthesiology* **104**:527–536.
- Gottrup H, Hansen PO, Arendt-Nielsen L, and Jensen TS (2000b) Differential effects of systemically administered ketamine and lidocaine on dynamic and static hyperalgesia induced by intradermal capsaicin in humans. *Br J Anaesth* **84**:155–162.
- Gottrup H, Juhl G, Kristensen AD, Lai R, Chizh BA, Brown J, Bach FW, and Jensen TS (2004) Chronic oral gabapentin reduces elements of central sensitization in human experimental hyperalgesia. *Anesthesiology* **101**:1400–1408.
- Gracely RH (1999) Pain measurement. *Acta Anaesthesiol Scand* **43**:897–908.
- Grach M, Massalha W, Pud D, Adler R, and Eisenberg E (2004) Can coadministration of oxycodone and morphine produce analgesic synergy in humans? An experimental cold pain study. *Br J Clin Pharmacol* **58**:235–242.
- Granot M, Granovsky Y, Sprecher E, Nir RR, and Yarnitsky D (2006) Contact heat-evoked temporal summation: tonic versus repetitive-phasic stimulation. *Pain* **122**:295–305.
- Graven-Nielsen T (2006) Fundamentals of muscle pain, referred pain, and deep tissue hyperalgesia. *Scand J Rheumatol Suppl* **122**:1–43.
- Graven-Nielsen T (2001) Methods for induction and assessment of pain in humans with clinical and pharmacological examples, in *Methods in Pain Research* (Kruger L ed) pp 264–304. CRC Press, Boca Raton, FL.
- Graven-Nielsen T and Arendt-Nielsen L (2003) Induction and assessment of muscle pain, referred pain, and muscular hyperalgesia. *Curr Pain Headache Rep* **7**:443–451.
- Graven-Nielsen T, Arendt-Nielsen L, and Mense S (2002) Thermosensitivity of muscle: high-intensity thermal stimulation of muscle tissue induces muscle pain in humans. *J Physiol* **540**:647–656.
- Graven-Nielsen T, Aspegren Kendall S, Henriksson KG, Bengtsson M, Sörensen J, Johnson A, Gerdl B, and Arendt-Nielsen L (2000) Ketamine reduces muscle pain, temporal summation, and referred pain in fibromyalgia patients. *Pain* **85**:483–491.
- Graven-Nielsen T, Gibson SJ, Laursen RJ, Svensson P, and Arendt-Nielsen L (2002) Opioid-insensitive hypoalgesia to mechanical stimuli at sites ipsilateral and contralateral to experimental muscle pain in human volunteers. *Exp Brain Res* **146**:213–222.
- Graven-Nielsen T, Jansson Y, Segerdahl M, Kristensen JD, Mense S, Arendt-Nielsen L, and Sollevi A (2003) Experimental pain by ischaemic contractions compared with pain by intramuscular infusions of adenosine and hypertonic saline. *Eur J Pain* **7**:93–102.
- Graven-Nielsen T and Mense S (2001) The peripheral apparatus of muscle pain: evidence from animal and human studies. *Clin J Pain* **17**:2–10.
- Greenspan JD, Craft RM, LeResche L, Arendt-Nielsen L, Berkley KJ, Fillingim RB, Gold MS, Holdcroft A, Lautenbacher S, Mayer EA, et al. (2007) Studying sex and gender differences in pain and analgesia: a consensus report. *Pain* **132** (Suppl 1):S26–S45.
- Greenspan JD and McGillis SL (1991) Stimulus features relevant to the perception of sharpness and mechanically evoked cutaneous pain. *Somatosens Mot Res* **8**:137–147.
- Gregersen H and Christensen J (2000) Gastrointestinal tone. *Neurogastroenterol Motil* **12**:501–508.
- Gregersen H, Kwiatek MA, Schwizer W, and Tutuian R (2007) Contribution of sensitivity, volume and tone to visceral perception in the upper gastrointestinal tract in man: emphasis on testing. *Neurogastroenterol Motil* **19**:47–61.
- Grönblad M, Liesi P, Korkala O, Karaharju E, and Polak J (1984) Innervation of human bone periosteum by peptidergic nerves. *Anat Rec* **209**:297–299.
- Growcott JW, Stone A, Beise R, Stammer H, Tetzloff W, and Demy C (2000) Sensitivity of repeated interdigital web pinching to detect antinociceptive effects of ibuprofen. *Br J Clin Pharmacol* **49**:331–336.
- Guay DR, Awani WM, Halstenon CE, Findlay JW, Opsahl JA, Abraham PA, Jones EC, and Matzke GR (1987) Pharmacokinetics of codeine after single- and multiple-dose administration to normal volunteers. *J Clin Pharmacol* **27**:983–987.
- Guindon J and Hohmann AG (2009) The endocannabinoid system and pain. *CNS Neurol Disord Drug Targets* **8**:403–421.
- Gustorff B, Felleiter P, Nahlik G, Brannath W, Hoerauf KH, Spacek A, and Kress HG (2001) The effect of remifentanyl on the heat pain threshold in volunteers. *Anesth Analg* **92**:369–374.
- Gustorff B, Hoehcht K, Sycha T, Felouzis E, Lehr S, and Kress HG (2004) The effects of remifentanyl and gabapentin on hyperalgesia in a new extended inflammatory skin pain model in healthy volunteers. *Anesth Analg* **98**:401–407.
- Hallin RG, Torebjörk HE, and Wiesenfeld Z (1982) Nociceptors and warm receptors innervated by C fibres in human skin. *J Neurol Neurosurg Psychiatry* **45**:313–319.
- Hamilton RC, Dundee JW, Clarke RS, Loan WB, and Morrison JD (1967) Alterations in response to somatic pain associated with anaesthesia. 18. Studies with some opiate antagonists. *Br J Anaesth* **39**:490–502.
- Hammer J and Vogelsang H (2007) Characterization of sensations induced by capsaicin in the upper gastrointestinal tract. *Neurogastroenterol Motil* **19**:279–287.
- Handwerker HO and Kobal G (1993) Psychophysiology of experimentally induced pain. *Physiol Rev* **73**:639–671.
- Harvey VL and Dickenson AH (2008) Mechanisms of pain in nonmalignant disease. *Curr Opin Support Palliat Care* **2**:133–139.
- Hatem S, Attal N, Willer JC, and Bouhassira D (2006) Psychophysical study of the effects of topical application of menthol in healthy volunteers. *Pain* **122**:190–196.
- Hathway GJ and Fitzgerald M (2006) Time course and dose-dependence of nerve growth factor-induced secondary hyperalgesia in the mouse. *J Pain* **7**:57–61.
- Heinricher MM and Morgan MM (1999) Supraspinal mechanisms of opioid analgesia, in *Opioids in Pain Control: Basic and Clinical Aspects* (Stein C ed) pp 46–69. Cambridge University Press, Cambridge.
- Heinricher MM, Tavares I, Leith JL, and Lumb BM (2009) Descending control of nociception: Specificity, recruitment and plasticity. *Brain Res Rev* **60**:214–225.

- Henriksen G and Willoch F (2008) Imaging of opioid receptors in the central nervous system. *Brain* **131**:1171–1196.
- Hernández N, Dmitrieva N, and Vanegas H (1994) Medullary on-cell activity during tail-flick inhibition produced by heterotopic noxious stimulation. *Pain* **58**:393–401.
- Hill HF, Chapman CR, Saeger LS, Bjurström R, Walter MH, Schoene RB, and Kippes M (1990) Steady-state infusions of opioids in human. II. Concentration-effect relationships and therapeutic margins. *Pain* **43**:69–79.
- Hill R (2000) NK1 (substance P) receptor antagonists—why are they not analgesic in humans? *Trends Pharmacol Sci* **21**:244–246.
- Hill RG (2001) Molecular basis for the perception of pain. *Neuroscientist* **7**:282–292.
- Hobson AR, Khan RW, Sarkar S, Furlong PL, and Aziz Q (2004) Development of esophageal hypersensitivity following experimental duodenal acidification. *Am J Gastroenterol* **99**:813–820.
- Högger P and Rohdewald P (1999) Comparison of tilidine/naloxone, tramadol and bromfenac in experimental pain: a double-blind randomized crossover study in healthy human volunteers. *Int J Clin Pharmacol Ther* **37**:377–385.
- Hood DD, Curry R, and Eisenach JC (2003) Intravenous remifentanyl produces withdrawal hyperalgesia in volunteers with capsaicin-induced hyperalgesia. *Anesth Analg* **97**:810–815.
- Houghton LA, Fell C, Whorwell PJ, Jones I, Sudworth DP, and Gale JD (2007) Effect of a second-generation alpha2delta ligand (pregabalin) on visceral sensation in hypersensitive patients with irritable bowel syndrome. *Gut* **56**:1218–1225.
- Hughes AM, Rhodes J, Fisher G, Sellers M, and Growcott JW (2002) Assessment of the effect of dextromethorphan and ketamine on the acute nociceptive threshold and wind-up of the second pain response in healthy male volunteers. *Br J Clin Pharmacol* **53**:604–612.
- Hummel T, Hummel C, Friedel I, Pauli E, and Kobal G (1994) A comparison of the antinociceptive effects of imipramine, tramadol and amitriptyline. *Br J Clin Pharmacol* **37**:325–333.
- Iannetti GD and Mouraux A (2010) From the neuromatrix to the pain matrix (and back). *Exp Brain Res* **205**:1–12.
- Iannetti GD and Wise RG (2007) BOLD functional MRI in disease and pharmacological studies: room for improvement? *Magn Reson Imaging* **25**:978–988.
- Iannetti GD, Zambreanu L, Wise RG, Buchanan TJ, Huggins JP, Smart TS, Vennart W, and Tracey I (2005) Pharmacological modulation of pain-related brain activity during normal and central sensitization states in humans. *Proc Natl Acad Sci USA* **102**:18195–18200.
- Ikeda H, Asai T, and Murase K (2000) Robust changes of afferent-induced excitation in the rat spinal dorsal horn after conditioning high-frequency stimulation. *J Neurophysiol* **83**:2412–2420.
- Ilkjaer S, Bach LF, Nielsen PA, Wernberg M, and Dahl JB (2000) Effect of preoperative oral dextromethorphan on immediate and late postoperative pain and hyperalgesia after total abdominal hysterectomy. *Pain* **86**:19–24.
- Ilkjaer S, Petersen KL, Brennum J, Wernberg M, and Dahl JB (1996) Effect of systemic N-methyl-D-aspartate receptor antagonist (ketamine) on primary and secondary hyperalgesia in humans. *Br J Anaesth* **76**:829–834.
- Jänig W, Haupt-Schade P, and Kohler W (1993) Afferent innervation of the colon: the neurophysiological basis for visceral sensation and pain, in *Basic and Clinical Aspects of Chronic Abdominal Pain* (Mayer EA and Raybould HE eds) pp 71–86, Elsevier, Amsterdam.
- Joly V, Richebe P, Guignard B, Fletcher D, Maurette P, Sessler DI, and Chauvin M (2005) Remifentanyl-induced postoperative hyperalgesia and its prevention with small-dose ketamine. *Anesthesiology* **103**:147–155.
- Jones SF, McQuay HJ, Moore RA, and Hand CW (1988) Morphine and ibuprofen compared using the cold pressor test. *Pain* **34**:117–122.
- Jonker JW, Wagenaar E, van Deemter L, Gottschlich R, Bender HM, Dasenbrock J, and Schinkel AH (1999) Role of blood-brain barrier P-glycoprotein in limiting brain accumulation and sedative side-effects of asimadoline, a peripherally acting analgesic drug. *Br J Pharmacol* **127**:43–50.
- Jørum E, Warncke T, and Stubhaug A (2003) Cold allodynia and hyperalgesia in neuropathic pain: the effect of N-methyl-D-aspartate (NMDA) receptor antagonist ketamine—a double-blind, cross-over comparison with alfentanil and placebo. *Pain* **101**:229–235.
- Julius D and Basbaum AI (2001) Molecular mechanisms of nociception. *Nature* **413**:203–210.
- Jung K, Larsen LE, Rottmann S, and Ellrich J (2011) Heterotopic low-frequency stimulation induces nociceptive LTD within the same central receptive field in man. *Exp Brain Res* **212**:189–198.
- Jung K, Rottmann S, and Ellrich J (2009) Long-term depression of spinal nociception and pain in man: influence of varying stimulation parameters. *Eur J Pain* **13**:161–170.
- Kähkönen S (2006) Magnetoencephalography (MEG): a non-invasive tool for studying cortical effects in psychopharmacology. *Int J Neuropsychopharmacol* **9**:367–372.
- Kalso E (2007) How different is oxycodone from morphine? *Pain* **132**:227–228.
- Kalso E (2005) Oxycodone. *J Pain Symptom Manage* **29**:S47–S56.
- Karashima Y, Damann N, Prenen J, Talavera K, Segal A, Voets T, and Nilius B (2007) Bimodal action of menthol on the transient receptor potential channel TRPA1. *J Neurosci* **27**:9874–9884.
- Karst M, Wippermann S, and Ahrens J (2010) Role of cannabinoids in the treatment of pain and (painful) spasticity. *Drugs* **70**:2409–2438.
- Katz J and Melzack R (1999) Measurement of pain. *Surg Clin North Am* **79**:231–252.
- Kern D, Pelle-Lancien E, Luce V, and Bouhassira D (2008) Pharmacological dissection of the paradoxical pain induced by a thermal grill. *Pain* **135**:291–299.
- Kidd BL and Urban LA (2001) Mechanisms of inflammatory pain. *Br J Anaesth* **87**:3–11.
- Kilo S, Forster C, Geisslinger G, Brune K, and Handwerker HO (1995) Inflammatory models of cutaneous hyperalgesia are sensitive to effects of ibuprofen in man. *Pain* **62**:187–193.
- Kilo S, Schmelz M, Koltzenburg M, and Handwerker HO (1994) Different patterns of hyperalgesia induced by experimental inflammation in human skin. *Brain* **117**:385–396.
- Kinkelin I, Bröcker EB, Koltzenburg M, and Carlton SM (2000) Localization of ionotropic glutamate receptors in peripheral axons of human skin. *Neurosci Lett* **283**:149–152.
- Kinser AM, Sands WA, and Stone MH (2009) Reliability and validity of a pressure algometer. *J Strength Cond Res* **23**:312–314.
- Klamt JG and Posner J (1999) Effects of lamotrigine on pain-induced chemosomatosensory evoked potentials. *Anaesthesia* **54**:774–777.
- Klein T, Magerl W, Hopf HC, Sandkühler J, and Treede RD (2004) Perceptual correlates of nociceptive long-term potentiation and long-term depression in humans. *J Neurosci* **24**:964–971.
- Knowles CH and Aziz Q (2009) Basic and clinical aspects of gastrointestinal pain. *Pain* **141**:191–209.
- Kobal G (1985) Pain-related electrical potentials of the human nasal mucosa elicited by chemical stimulation. *Pain* **22**:151–163.
- Kobal G, Hummel C, Gruber M, Geisslinger G, and Hummel T (1994) Dose-related effects of ibuprofen on pain-related potentials. *Br J Clin Pharmacol* **37**:445–452.
- Kobal G, Hummel C, Nuernberg B, and Brune K (1990) Effects of pentazocine and acetylsalicylic acid on pain-rating, pain-related evoked potentials and vigilance in relationship to pharmacokinetic parameters. *Agents Actions* **29**:342–359.
- Kola I and Landis J (2004) Can the pharmaceutical industry reduce attrition rates? *Nat Rev Drug Discov* **3**:711–715.
- Koltzenburg M, Lundberg LE, and Torebjörk HE (1992) Dynamic and static components of mechanical hyperalgesia in human hairy skin. *Pain* **51**:207–219.
- Koltzenburg M, Pokorny R, Gasser UE, and Richarz U (2006) Differential sensitivity of three experimental pain models in detecting the analgesic effects of transdermal fentanyl and buprenorphine. *Pain* **126**:165–174.
- Koppert W, Angst M, Alsheimer M, Sittl R, Albrecht S, Schüttler J, and Schmelz M (2003a) Naloxone provokes similar pain facilitation as observed after short-term infusion of remifentanyl in humans. *Pain* **106**:91–99.
- Koppert W, Dern SK, Sittl R, Albrecht S, Schüttler J, and Schmelz M (2001) A new model of electrically evoked pain and hyperalgesia in human skin: the effects of intravenous alfentanil, S(+)-ketamine, and lidocaine. *Anesthesiology* **95**:395–402.
- Koppert W, Ihmsen H, Körber N, Wehrfritz A, Sittl R, Schmelz M, and Schüttler J (2005) Different profiles of buprenorphine-induced analgesia and antihyperalgesia in a human pain model. *Pain* **118**:15–22.
- Koppert W, Likar R, Geisslinger G, Zeck S, Schmelz M, and Sittl R (1999) Peripheral antihyperalgesic effect of morphine to heat, but not mechanical, stimulation in healthy volunteers after ultraviolet-B irradiation. *Anesth Analg* **88**:117–122.
- Koppert W, Sittl R, Scheuber K, Alsheimer M, Schmelz M, and Schüttler J (2003b) Differential modulation of remifentanyl-induced analgesia and postinfusion hyperalgesia by S-ketamine and clonidine in humans. *Anesthesiology* **99**:152–159.
- Krurup AL, Ny L, Astrand M, Bajor A, Hvid-Jensen F, Hansen MB, Simrén M, Funch-Jensen P, and Drewes AM (2011) Randomised clinical trial: the efficacy of a transient receptor potential vanilloid 1 antagonist AZD1386 in human oesophageal pain. *Aliment Pharmacol Ther* **33**:1113–1122.
- Krishnan AV, Lin CS, Park SB, and Kiernan MC (2009) Axonal ion channels from bench to bedside: a translational neuroscience perspective. *Prog Neurobiol* **89**:288–313.
- Kuiken SD, Tytgat GN, and Boeckxstaens GE (2003) The selective serotonin reuptake inhibitor fluoxetine does not change rectal sensitivity and symptoms in patients with irritable bowel syndrome: a double blind, randomized, placebo-controlled study. *Clin Gastroenterol Hepatol* **1**:219–228.
- Kumar K, Polston GR, and Wallace MS (2006) The effect of intravenous ketorolac on capsaicin-induced deep tissue hyperalgesia. *Anesth Analg* **103**:696–702.
- Kuner R (2010) Central mechanisms of pathological pain. *Nat Med* **16**:1258–1266.
- Labuz D, Mousa SA, Schäfer M, Stein C, and Machelska H (2007) Relative contribution of peripheral versus central opioid receptors to antinociception. *Brain Res* **1160**:30–38.
- Lam DK, Sessle BJ, Cairns BE, and Hu JW (2005) Neural mechanisms of temporomandibular joint and masticatory muscle pain: a possible role for peripheral glutamate receptor mechanisms. *Pain Res Manag* **10**:145–152.
- LaMotte RH, Lundberg LE, and Torebjörk HE (1992) Pain, hyperalgesia and activity in nociceptive C units in humans after intradermal injection of capsaicin. *J Physiol* **448**:749–764.
- LaMotte RH, Shain CN, Simone DA, and Tsai EF (1991) Neurogenic hyperalgesia: psychophysical studies of underlying mechanisms. *J Neurophysiol* **66**:190–211.
- Larsson M (2009) Ionotropic glutamate receptors in spinal nociceptive processing. *Mol Neurobiol* **40**:260–288.
- Laughlin TM, Tram KV, Wilcox GL, and Birnbaum AK (2002) Comparison of anti-epileptic drugs tiagabine, lamotrigine, and gabapentin in mouse models of acute, prolonged, and chronic nociception. *J Pharmacol Exp Ther* **302**:1168–1175.
- Lawand NB, Willis WD, and Westlund KN (1997) Excitatory amino acid receptor involvement in peripheral nociceptive transmission in rats. *Eur J Pharmacol* **324**:169–177.
- Le Bars D (2002) The whole body receptive field of dorsal horn multireceptive neurones. *Brain Res Brain Res Rev* **40**:29–44.
- Le Bars D, Chitour D, Kraus E, Clot AM, Dickenson AH, and Besson JM (1981) The effect of systemic morphine upon diffuse noxious inhibitory controls (DNIC) in the rat: evidence for a lifting of certain descending inhibitory controls of dorsal horn convergent neurones. *Brain Res* **215**:257–274.
- Le Bars D, Dickenson AH, and Besson JM (1979a) Diffuse noxious inhibitory controls (DNIC). I. Effects on dorsal horn convergent neurones in the rat. *Pain* **6**:283–304.
- Le Bars D, Dickenson AH, and Besson JM (1979b) Diffuse noxious inhibitory controls (DNIC). II. Lack of effect on non-convergent neurones, supraspinal involvement and theoretical implications. *Pain* **6**:305–327.
- Le Bars D, Gozariu M, and Cadden SW (2001) Animal models of nociception. *Pharmacol Rev* **53**:597–652.
- Le Bars D, Guilbaud G, Jurna I, and Besson JM (1976) Differential effects of

- morphine on responses of dorsal horn lamina V type cells elicited by A and C fibre stimulation in the spinal cat. *Brain Res* **115**:518–524.
- Le Bars D, Villanueva L, Bouhassira D, and Willer JC (1992a) Diffuse noxious inhibitory controls (DNIC) in animals and in man. *Patol Fiziol Eksp Ter* (4):55–65.
- Le Bars D, Willer JC, and De Broucker T (1992b) Morphine blocks descending pain inhibitory controls in humans. *Pain* **48**:13–20.
- Le Pera D, Valeriani M, Niddam D, Chen AC, and Arendt-Nielsen L (2002) Contact heat evoked potentials to painful and non-painful stimuli: effect of attention towards stimulus properties. *Brain Topogr* **15**:115–123.
- Lee KJ, Kim JH, and Cho SW (2005) Gabapentin reduces rectal mechanosensitivity and increases rectal compliance in patients with diarrhoea-predominant irritable bowel syndrome. *Aliment Pharmacol Ther* **22**:981–988.
- Lelic D, Gratkowski M, Hennings K, and Drewes AM (2011) Multichannel matching pursuit validation and clustering—a simulation and empirical study. *J Neurosci Methods* **196**:190–200.
- Lelic D, Gratkowski M, Valeriani M, Arendt-Nielsen L, and Drewes AM (2009) Inverse modeling on decomposed electroencephalographic data: a way forward? *J Clin Neurophysiol* **26**:227–235.
- Lembo T, Naliboff BD, Matin K, Munakata J, Parker RA, Gracely RH, and Mayer EA (2000) Irritable bowel syndrome patients show altered sensitivity to exogenous opioids. *Pain* **87**:137–147.
- Lemming D, Sørensen J, Graven-Nielsen T, Arendt-Nielsen L, and Gerdle B (2005) The responses to pharmacological challenges and experimental pain in patients with chronic whiplash-associated pain. *Clin J Pain* **21**:412–421.
- Lenz H, Sandvik L, Qvigstad E, Bjerkelund CE, and Raeder J (2009) A comparison of intravenous oxycodone and intravenous morphine in patient-controlled postoperative analgesia after laparoscopic hysterectomy. *Anesth Analg* **109**:1279–1283.
- Leung A, Wallace MS, Ridgeway B, and Yaksh T (2001) Concentration-effect relationship of intravenous alfentanil and ketamine on peripheral neurosensory thresholds, allodynia and hyperalgesia of neuropathic pain. *Pain* **91**:177–187.
- Leung AY, Wallace MS, Schulte G, and Yaksh TL (2005) Qualitative and quantitative characterization of the thermal grill. *Pain* **116**:26–32.
- Lever JR (2007) PET and SPECT imaging of the opioid system: receptors, radioligands and avenues for drug discovery and development. *Curr Pharm Des* **13**:33–49.
- Lewis T (1936) Experiments relating to cutaneous hyperalgesia and its spread through somatic nerves. *Clin Sci* **2**:373–421.
- Li X, Petrini L, Wang L, Defrin R, and Arendt-Nielsen L (2009) The importance of stimulus parameters for the experience of the thermal grill illusion. *Neurophysiol Clin* **39**:275–282.
- Lin JH (1995) Species similarities and differences in pharmacokinetics. *Drug Metab Dispos* **23**:1008–1021.
- Lin JH, Chen IW, and deLuna FA (1994) Nonlinear kinetics of alendronate. Plasma protein binding and bone uptake. *Drug Metab Dispos* **22**:400–405.
- Lin JH and Yamazaki M (2003) Role of P-glycoprotein in pharmacokinetics: clinical implications. *Clin Pharmacokinet* **42**:59–98.
- Liu XJ and Salter MW (2010) Glutamate receptor phosphorylation and trafficking in pain plasticity in spinal cord dorsal horn. *Eur J Neurosci* **32**:278–289.
- Loram LC, Mitchell D, and Fuller A (2005) Rofecoxib and tramadol do not attenuate delayed-onset muscle soreness or ischaemic pain in human volunteers. *Can J Physiol Pharmacol* **83**:1137–1145.
- Lorenz IH, Kolbitsch C, Hinteregger M, Bauer P, Spiegel M, Luger TJ, Schmidauer C, Streif W, Pfeiffer KP, and Benzer A (2003) Remifentanyl and nitrous oxide reduce changes in cerebral blood flow velocity in the middle cerebral artery caused by pain. *Br J Anaesth* **90**:296–299.
- Lötsch J (2005) Pharmacokinetic-pharmacodynamic modeling of opioids. *J Pain Symptom Manage* **29**:S90–103.
- Lötsch J and Angst MS (2003) The mu-opioid agonist remifentanyl attenuates hyperalgesia evoked by blunt and punctuated stimuli with different potency: a pharmacological evaluation of the freeze lesion in humans. *Pain* **102**:151–161.
- Lowe PJ, Hijazi Y, Luttringer O, Yin H, Sarangapani R, and Howard D (2007) On the anticipation of the human dose in first-in-man trials from preclinical and prior clinical information in early drug development. *Xenobiotica* **37**:1331–1354.
- Luginbühl M, Gerber A, Schneider TW, Petersen-Felix S, Arendt-Nielsen L, and Curatolo M (2003) Modulation of remifentanyl-induced analgesia, hyperalgesia, and tolerance by small-dose ketamine in humans. *Anesth Analg* **96**:726–732.
- Luginbühl M, Schneider TW, Petersen-Felix S, Arendt-Nielsen L, and Zbinden AM (2001) Comparison of five experimental pain tests to measure analgesic effects of alfentanil. *Anesthesiology* **95**:22–29.
- Maggi CA (1993) The dual, sensory and “efferent” function of the capsaicin-sensitive primary sensory neurons in the urinary bladder and uretra, in *Nervous Control of the Urogenital System* (Maggi CA ed) pp 382–422, Harwood Academic Publishers, Switzerland.
- Maihöfner C, Ringler R, Herndobler F, and Koppert W (2007) Brain imaging of analgesic and antihyperalgesic effects of cyclooxygenase inhibition in an experimental human pain model: a functional MRI study. *Eur J Neurosci* **26**:1344–1356.
- Mao J (2009) Translational pain research: achievements and challenges. *J Pain* **10**:1001–1011.
- Mauderli AP, Vierck CJ, Jr, Cannon RL, Rodrigues A, and Shen C (2003) Relationships between skin temperature and temporal summation of heat and cold pain. *J Neurophysiol* **90**:100–109.
- Maxwell DJ, Belle MD, Cheunjuang O, Stewart A, and Morris R (2007) Morphology of inhibitory and excitatory interneurons in superficial laminae of the rat dorsal horn. *J Physiol* **584**:521–533.
- Mayer EA, Berman S, Derbyshire SW, Suyenobu B, Chang L, Fitzgerald L, Mandelkern M, Hamm L, Vogt B, and Naliboff BD (2002) The effect of the 5-HT₃ receptor antagonist, alonsetron, on brain responses to visceral stimulation in irritable bowel syndrome patients. *Aliment Pharmacol Ther* **16**:1357–1366.
- Mayer EA, Bradesi S, Chang L, Spiegel BM, Bueller JA, and Naliboff BD (2008) Functional GI disorders: from animal models to drug development. *Gut* **57**:384–404.
- McMahon SB and Koltzenburg M (2006) *Textbook of Pain*, 5th ed. Elsevier Churchill Livingstone, London.
- McNamee T, Speegle D, Lawand N, Lisse J, and Westlund KN (2000) Excitatory amino acid profiles of synovial fluid from patients with arthritis. *J Rheumatol* **27**:739–745.
- Melzack R (1975) The McGill Pain Questionnaire: major properties and scoring methods. *Pain* **1**:277–299.
- Mense S (1997) *Muscle Pain: Basic Mechanisms and Clinical Correlates in Progress in Pain Research and Management* (Jensen TS, Turner TA and Wiesenfeld-Hallin Z eds) pp 479–496, IASP Press, Seattle.
- Mertz H, Fass R, Kodner A, Yan-Go F, Fullerton S, and Mayer EA (1998) Effect of amitriptyline on symptoms, sleep, and visceral perception in patients with functional dyspepsia. *Am J Gastroenterol* **93**:160–165.
- Meyer RA, Ringkamp M, Campbell JN and Raja SN (2005) Peripheral mechanisms of cutaneous nociception, in *Textbook of Pain* (McMahon SB and Koltzenburg M eds) 5th ed., pp 3–35, Elsevier Churchill Livingstone, London.
- Michaelis M, Häbler HJ, and Jäenig W (1996) Silent afferents: a separate class of primary afferents? *Clin Exp Pharmacol Physiol* **23**:99–105.
- Minami K, Uezono Y, and Ueta Y (2007) Pharmacological aspects of the effects of tramadol on G-protein coupled receptors. *J Pharmacol Sci* **103**:253–260.
- Minami M and Satoh M (1995) Molecular biology of the opioid receptors: structures, functions and distributions. *Neurosci Res* **23**:121–145.
- Modir JG and Wallace MS (2010) Human experimental pain models 3: heat/capsaicin sensitization and intradermal capsaicin models. *Methods Mol Biol* **617**:169–174.
- Mölniche S, Dahl JB, and Kehlet H (1993) Peripheral antinociceptive effects of morphine after burn injury. *Acta Anaesthesiol Scand* **37**:710–712.
- Moort R, Crispel Y, Lev R, Pud D, and Yarnitsky D (2011) Temporal changes in cortical activation during conditioned pain modulation (CPM), a LORETA study. *Pain* **152**:1469–1477.
- Moort R, Pud D, Sprecher E, Sharvit G, and Yarnitsky D (2010) ‘Pain inhibits pain’ mechanisms: Is pain modulation simply due to distraction? *Pain* **150**:113–120.
- Mørch CD, Andersen OK, Graven-Nielsen T, and Arendt-Nielsen L (2007) Nociceptive withdrawal reflexes evoked by uniform-temperature laser heat stimulation of large skin areas in humans. *J Neurosci Methods* **160**:85–92.
- Morgan V, Pickens D, Gautam S, Kessler R, and Mertz H (2005) Amitriptyline reduces rectal pain related activation of the anterior cingulate cortex in patients with irritable bowel syndrome. *Gut* **54**:601–607.
- Mørk H, Ashina M, Bendtsen L, Olesen J, and Jensen R (2003) Experimental muscle pain and tenderness following infusion of endogenous substances in humans. *Eur J Pain* **7**:145–153.
- Mucha M, Ooi L, Linley JE, Mordaka P, Dalle C, Robertson B, Gamper N, and Wood IC (2010) Transcriptional control of KCNQ channel genes and the regulation of neuronal excitability. *J Neurosci* **30**:13235–13245.
- Naef M, Curatolo M, Petersen-Felix S, Arendt-Nielsen L, Zbinden A, and Brenneisen R (2003) The analgesic effect of oral delta-9-tetrahydrocannabinol (THC), morphine, and a THC-morphine combination in healthy subjects under experimental pain conditions. *Pain* **105**:79–88.
- Naef M, Russmann S, Petersen-Felix S, and Brenneisen R (2004) Development and pharmacokinetic characterization of pulmonary and intravenous delta-9-tetrahydrocannabinol (THC) in humans. *J Pharm Sci* **93**:1176–1184.
- Närhi M, Jyväsjärvi E, Virtanen A, Huopaniemi T, Ngassapa D, and Hirvonen T (1992) Role of intradental A- and C-type nerve fibres in dental pain mechanisms. *Proc Finn Dent Soc* **88** (Suppl 1):507–516.
- Negus SS, Vanderah TW, Brandt MR, Bilsky EJ, Becerra L, and Borsook D (2006) Preclinical assessment of candidate analgesic drugs: recent advances and future challenges. *J Pharmacol Exp Ther* **319**:507–514.
- Ness TJ (1995) Historical and clinical perspectives of visceral pain, in *Visceral Pain. Progress in Pain Research and Management* (Gebhart GF ed) pp 3–23, IASP Press, Seattle.
- Ness TJ and Gebhart GF (1990) Visceral pain: a review of experimental studies. *Pain* **41**:167–234.
- Neziri AY, Andersen OK, Petersen-Felix S, Radanov B, Dickenson AH, Scaramozzino P, Arendt-Nielsen L, and Curatolo M (2010) The nociceptive withdrawal reflex: normative values of thresholds and reflex receptive fields. *Eur J Pain* **14**:134–141.
- Neziri AY, Curatolo M, Nüesch E, Scaramozzino P, Andersen OK, Arendt-Nielsen L, and Jüni P (2011) Factor analysis of responses to thermal, electrical, and mechanical painful stimuli supports the importance of multi-modal pain assessment. *Pain* **152**:1146–1155.
- Nicol GD and Vasko MR (2007) Unraveling the story of NGF-mediated sensitization of nociceptive sensory neurons: ON or OFF the Trks? *Mol Interv* **7**:26–41.
- Nie H, Arendt-Nielsen L, Madeleine P, and Graven-Nielsen T (2006) Enhanced temporal summation of pressure pain in the trapezius muscle after delayed onset muscle soreness. *Exp Brain Res* **170**:182–190.
- Nielsen JC, Bjerring P, and Arendt-Nielsen L (1991) A comparison of the hypoalgesic effect of paracetamol in slow-release and plain tablets on laser-induced pain. *Br J Clin Pharmacol* **31**:267–270.
- Nielsen JC, Bjerring P, Arendt-Nielsen L, and Petterson KJ (1992) Analgesic efficacy of immediate and sustained release paracetamol and plasma concentration of paracetamol. Double blind, placebo-controlled evaluation using painful laser stimulation. *Eur J Clin Pharmacol* **42**:261–264.
- Nielsen JC, Bjerring P, Arendt-Nielsen L, and Petterson KJ (1990) A double-blind, placebo controlled, cross-over comparison of the analgesic effect of ibuprofen 400 mg and 800 mg on laser-induced pain. *Br J Clin Pharmacol* **30**:711–715.
- Niesters M, Dahan A, Swartjes M, Noppers I, Fillingim RB, Aarts L, and Sarton EY (2011) Effect of ketamine on endogenous pain modulation in healthy volunteers. *Pain* **152**:656–663.
- Noehr-Jensen L, Zwisler ST, Larsen F, Sindrup SH, Damkier P, and Brosen K (2009) Escitalopram is a weak inhibitor of the CYP2D6-catalyzed O-demethylation of (+)-tramadol but does not reduce the hypoalgesic effect in experimental pain. *Clin Pharmacol Ther* **86**:626–633.

- Norbury TA, MacGregor AJ, Urwin J, Spector TD, and McMahon SB (2007) Heritability of responses to painful stimuli in women: a classical twin study. *Brain* **130**:3041–3049.
- Nussbaum EL and Downes L (1998) Reliability of clinical pressure-pain algometric measurements obtained on consecutive days. *Phys Ther* **78**:160–169.
- Obara I, Parkitna JR, Korostynski M, Makuch W, Kaminska D, Przewlocka B, and Przewlocki R (2009) Local peripheral opioid effects and expression of opioid genes in the spinal cord and dorsal root ganglia in neuropathic and inflammatory pain. *Pain* **141**:283–291.
- Oertel BG, Preibisch C, Wallenhorst T, Hummel T, Geisslinger G, Lanfermann H, and Lötsch J (2008) Differential opioid action on sensory and affective cerebral pain processing. *Clin Pharmacol Ther* **83**:577–588.
- Olesen AE, Andresen T, Christrup LL, and Upton RN (2009a) Translational pain research: evaluating analgesic effect in experimental visceral pain models. *World J Gastroenterol* **15**:177–181.
- Olesen AE, Staahl C, Ali Z, Drewes AM, and Arendt-Nielsen L (2007) Effects of paracetamol combined with dextromethorphan in human experimental muscle and skin pain. *Basic Clin Pharmacol Toxicol* **101**:172–176.
- Olesen AE, Staahl C, Arendt-Nielsen L, and Drewes AM (2010a) Different effects of morphine and oxycodone in experimentally evoked hyperalgesia: a human translational study. *BR J Clin Pharmacol* **70**:189–200.
- Olesen AE, Staahl C, Brock C, Arendt-Nielsen L, and Drewes AM (2009b) Evoked human oesophageal hyperalgesia: a potential tool for analgesic evaluation? *Basic Clin Pharmacol Toxicol* **105**:126–136.
- Olesen SS, Bouwense SA, Wilder-Smith OH, van Goor H, and Drewes AM (2011a) Pregabalin reduces pain in patients with chronic pancreatitis in a randomized, controlled trial. *Gastroenterology* **141**:536–543.
- Olesen SS, Brock C, Krarup AL, Funch-Jensen P, Arendt-Nielsen L, Wilder-Smith OH, and Drewes AM (2010b) Descending inhibitory pain modulation is impaired in patients with chronic pancreatitis. *Clin Gastroenterol Hepatol* **8**:724–730.
- Olesen SS, Graversen C, Olesen AE, Frøkjær JB, Wilder-Smith O, van Goor H, Valeriani M, and Drewes AM (2011b) Randomised clinical trial: pregabalin attenuates experimental visceral pain through sub-cortical mechanisms in patients with painful chronic pancreatitis. *Aliment Pharmacol Ther* **34**:878–887.
- Olesen SS, Krarup AL, Brock C, and Drewes AM (2009c) Gastrointestinal sensations and pain: a review on basic, experimental and clinical findings. *Minerva Gastroenterol Dietol* **55**:301–313.
- Olesen SS, Olesen AE, Graversen F, Poulsen JL, Funch-Jensen P, Gregersen H, and Drewes AM (2009d) An endoscopic method for thermal and chemical stimulation of the human oesophagus. *Neurogastroenterol Motil* **21**:1250–e116.
- Olofson E, Romberg R, Bijl H, Mooren R, Engbers F, Kest B, and Dahan A (2005) Alfentanil and placebo analgesia: no sex differences detected in models of experimental pain. *Anesthesiology* **103**:130–139.
- Pazzaglia C and Valeriani M (2009) Brain-evoked potentials as a tool for diagnosing neuropathic pain. *Expert Rev Neurother* **9**:759–771.
- Pedersen J, Reddy H, Funch-Jensen P, Arendt-Nielsen L, Gregersen H, and Drewes AM (2004) Cold and heat pain assessment of the human oesophagus after experimental sensitisation with acid. *Pain* **110**:393–399.
- Pedersen JL (2000) Inflammatory pain in experimental burns in man. *Dan Med Bull* **47**:168–195.
- Pedersen JL and Kehlet H (1998) Hyperalgesia in a human model of acute inflammatory pain: a methodological study. *Pain* **74**:139–151.
- Peghini PL, Katz PO, and Castell DO (1998) Imipramine decreases oesophageal pain perception in human male volunteers. *Gut* **42**:807–813.
- Pertovaara A (2006) Noradrenergic pain modulation. *Prog Neurobiol* **80**:53–83.
- Peterbauer C, Larenza PM, Knobloch M, Theurillat R, Thormann W, Mevissen M, and Spadavecchia C (2008) Effects of a low dose infusion of racemic and S-ketamine on the nociceptive withdrawal reflex in standing ponies. *Vet Anaesth Analg* **35**:414–423.
- Petersen KL, Brennum J, and Dahl JB (1997) Experimental evaluation of the analgesic effect of ibuprofen on primary and secondary hyperalgesia. *Pain* **70**:167–174.
- Petersen KL, Jones B, Segredo V, Dahl JB, and Rowbotham MC (2001) Effect of remifentanyl on pain and secondary hyperalgesia associated with the heat-capsaicin sensitization model in healthy volunteers. *Anesthesiology* **94**:15–20.
- Petersen KL, Maloney A, Hoke F, Dahl JB, and Rowbotham MC (2003) A randomized study of the effect of oral lamotrigine and hydromorphone on pain and hyperalgesia following heat/capsaicin sensitization. *J Pain* **4**:400–406.
- Petersen LJ, Lyngholm AM, and Arendt-Nielsen L (2010) A novel model of inflammatory pain in human skin involving topical application of sodium lauryl sulfate. *Inflamm Res* **59**:775–781.
- Petersen-Felix S, Arendt-Nielsen L, Bak P, Bjerring P, Breivik H, Svensson P, and Zbinden AM (1994) Ondansetron does not inhibit the analgesic effect of alfentanil. *Br J Anaesth* **73**:326–330.
- Petersen-Felix S, Arendt-Nielsen L, Bak P, Fischer M, and Zbinden AM (1996) Psychophysical and electrophysiological responses to experimental pain may be influenced by sedation: comparison of the effects of a hypnotic (propofol) and an analgesic (alfentanil). *Br J Anaesth* **77**:165–171.
- Petty BG, Cornblath DR, Adornato BT, Chaudhry V, Flexner C, Wachsman M, Sinciropi D, Burton LE, and Peroutka SJ (1994) The effect of systemically administered recombinant human nerve growth factor in healthy human subjects. *Ann Neurol* **36**:244–246.
- Pickering G, Estève V, Loriot MA, Eschalié A, and Dubray C (2008) Acetaminophen reinforces descending inhibitory pain pathways. *Clin Pharmacol Ther* **84**:47–51.
- Pinto M, Castro AR, Tshudy F, Wilson SP, Lima D, and Tavares I (2008) Opioids modulate pain facilitation from the dorsal reticular nucleus. *Mol Cell Neurosci* **39**:508–518.
- Plaghki L and Mouraux A (2003) How do we selectively activate skin nociceptors with a high power infrared laser? Physiology and biophysics of laser stimulation. *Neurophysiol Clin* **33**:269–277.
- Plesan A, Sollevi A, and Segerdahl M (2000) The N-methyl-D-aspartate-receptor antagonist dextromethorphan lacks analgesic effect in a human experimental ischemic pain model. *Acta Anaesthesiol Scand* **44**:924–928.
- Poitras P, Riberdy Poitras M, Plourde V, Boivin M, and Verrier P (2002) Evolution of visceral sensitivity in patients with irritable bowel syndrome. *Dig Dis Sci* **47**:914–920.
- Polianskis R, Graven-Nielsen T, and Arendt-Nielsen L (2001) Computer-controlled pneumatic pressure algometry—a new technique for quantitative sensory testing. *Eur J Pain* **5**:267–277.
- Popescu A, LeResche L, Truelove EL, and Drangsholt MT (2010) Gender differences in pain modulation by diffuse noxious inhibitory controls: a systematic review. *Pain* **150**:309–318.
- Posner J (1984) A modified submaximal effort tourniquet test for evaluation of analgesics in healthy volunteers. *Pain* **19**:143–151.
- Poulsen L, Arendt-Nielsen L, Brøsen K, Nielsen KK, Gram LF, and Sindrup SH (1995) The hypoalgesic effect of imipramine in different human experimental pain models. *Pain* **60**:287–293.
- Poulsen L, Arendt-Nielsen L, Brøsen K, and Sindrup SH (1996a) The hypoalgesic effect of tramadol in relation to CYP2D6. *Clin Pharmacol Ther* **60**:636–644.
- Poulsen L, Brøsen K, Arendt-Nielsen L, Gram LF, Elbaek K, and Sindrup SH (1996b) Codeine and morphine in extensive and poor metabolizers of sparteine: pharmacokinetics, analgesic effect and side effects. *Eur J Clin Pharmacol* **51**:289–295.
- Pöyhkä R and Vainio A (2006) Topically administered ketamine reduces capsaicin-evoked mechanical hyperalgesia. *Clin J Pain* **22**:32–36.
- Price DD (2002) Central neural mechanisms that interrelate sensory and affective dimensions of pain. *Mol Interv* **2**:392–403, 339.
- Price DD (2000) Psychological and neural mechanisms of the affective dimension of pain. *Science* **288**:1769–1772.
- Price DD, Harkins SW, Rafii A, and Price C (1986) A simultaneous comparison of fentanyl's analgesic effects on experimental and clinical pain. *Pain* **24**:197–203.
- Price DD, Staud R, Robinson ME, Mauderli AP, Cannon R, and Vierck CJ (2002) Enhanced temporal summation of second pain and its central modulation in fibromyalgia patients. *Pain* **99**:49–59.
- Price DD, Von der Gruen A, Miller J, Rafii A, and Price C (1985) A psychophysical analysis of morphine analgesia. *Pain* **22**:261–269.
- Prior A and Read NW (1993) Reduction of rectal sensitivity and post-prandial motility by granisetron, a 5-HT₃-receptor antagonist, in patients with irritable bowel syndrome. *Aliment Pharmacol Ther* **7**:175–180.
- Pud D, Granovsky Y, and Yarnitsky D (2009) The methodology of experimentally induced diffuse noxious inhibitory control (DNIC)-like effect in humans. *Pain* **144**:16–19.
- Pud D, Yarnitsky D, Sprecher E, Rogowski Z, Adler R, and Eisenberg E (2006) Can personality traits and gender predict the response to morphine? An experimental cold pain study. *Eur J Pain* **10**:103–112.
- Quante M, Scharein E, Zimmermann R, Langer-Brauburger B, and Bromm B (2004) Dissociation of morphine analgesia and sedation evaluated by EEG measures in healthy volunteers. *Arzneimittelforschung* **54**:143–151.
- Raft D, Gregg J, Ghia J, and Harris L (1977) Effects of intravenous tetrahydrocannabinol on experimental and surgical pain. Psychological correlates of the analgesic response. *Clin Pharmacol Ther* **21**:26–33.
- Ramagge-Morin PL and Gilmour H (2010) Chronic pain at ages 12 to 44. *Health Rep* **21**:53–61.
- Read NW, Abitbol JL, Bardhan KD, Whorwell PJ, and Freitag B (1997) Efficacy and safety of the peripheral kappa agonist fedotozine versus placebo in the treatment of functional dyspepsia. *Gut* **41**:664–668.
- Reid KJ, Harker J, Bala MM, Truysers C, Kellen E, Bekkering GE, and Kleijnen J (2011) Epidemiology of chronic non-cancer pain in Europe: narrative review of prevalence, pain treatments and pain impact. *Curr Med Res Opin* **27**:449–462.
- Renner B, Clarke G, Grattan T, Beisel A, Mueller C, Werner U, Kobal G, and Brune K (2007) Caffeine accelerates absorption and enhances the analgesic effect of acetaminophen. *J Clin Pharmacol* **47**:715–726.
- Ribeiro-Dasilva MC, Shinal RM, Glover T, Williams RS, Staud R, Riley JL 3rd, and Fillingim RB (2011) Evaluation of menstrual cycle effects on morphine and pentazocine analgesia. *Pain* **152**:614–622.
- Riering K, Rewerts C, and Zieglgänsberger W (2004) Analgesic effects of 5-HT₃ receptor antagonists. *Scand J Rheumatol Suppl* **119**:19–23.
- Rivera-Arconada I, Martinez-Gomez J, and Lopez-Garcia JA (2004) M-current modulators alter rat spinal nociceptive transmission: an electrophysiological study in vitro. *Neuropharmacology* **46**:598–606.
- Roberts JD, Gennings C, and Shih M (2006) Synergistic affective analgesic interaction between delta-9-tetrahydrocannabinol and morphine. *Eur J Pharmacol* **530**:54–58.
- Roberts K, Papadaki A, Gonçalves C, Tighe M, Atherton D, Shenoy R, McRobbie D, and Anand P (2008) Contact Heat Evoked Potentials Using Simultaneous Eeg And Fmri And Their Correlation With Evoked Pain. *BMC Anesthesiol* **8**:8.
- Rohdewald P, Granitzki HW, and Neddermann E (1988) Comparison of the analgesic efficacy of metamizole and tramadol in experimental pain. *Pharmacology* **37**:209–217.
- Rolke R, Baron R, Maier C, Tölle TR, Treede RD, Beyer A, Binder A, Birbaumer N, Birklein F, Bötefür IC, et al. (2006) Quantitative sensory testing in the German Research Network on Neuropathic Pain (DFNS): standardized protocol and reference values. *Pain* **123**:231–243.
- Romundstad L, Stubhaug A, Niemi G, Rosseland LA, and Breivik H (2006) Adding propacetamol to ketorolac increases the tolerance to painful pressure. *Eur J Pain* **10**:177–183.
- Roques BP, Noble F, and Fournie-Zaluski MC (1999) Endogenous opioid peptides and analgesia, in *Opioids in Pain Control: Mechanisms and Clinical Implications* (Stein C ed) pp 21–46, Cambridge University Press, Cambridge.
- Rosendal L, Larsson B, Kristiansen J, Peolsson M, Søggaard K, Kjaer M, Sørensen J, and Gerdlé B (2004) Increase in muscle nociceptive substances and anaerobic

- metabolism in patients with trapezius myalgia: microdialysis in rest and during exercise. *Pain* **112**:324–334.
- Ross FB and Smith MT (1997) The intrinsic antinociceptive effects of oxycodone appear to be kappa-opioid receptor mediated. *Pain* **73**:151–157.
- Rothwell PM (2005) External validity of randomised controlled trials: “to whom do the results of this trial apply?”. *Lancet* **365**:82–93.
- Rottmann S, Jung K, Vohn R, and Ellrich J (2010) Long-term depression of pain-related cerebral activation in healthy man: an fMRI study. *Eur J Pain* **14**:615–624.
- Rukwied R, Mayer A, Kluschina O, Obreja O, Schley M, and Schmelz M (2010a) NGF induces non-inflammatory localized and lasting mechanical and thermal hyper-sensitivity in human skin. *Pain* **148**:407–413.
- Rukwied R, Schley M, Forsch E, Obreja O, Dusch M, and Schmelz M (2010b) Nerve growth factor-evoked nociceptor sensitization in pig skin in vivo. *J Neurosci Res* **88**:2066–2072.
- Ruscheweyh R, Wilder-Smith O, Drdla R, Liu XG, and Sandkühler J (2011) Long-term potentiation in spinal nociceptive pathways as a novel target for pain therapy. *Mol Pain* **7**:20.
- Samer CF, Daali Y, Wagner M, Hopfgartner G, Eap CB, Rebsamen MC, Rossier MF, Hochstrasser D, Dayer P, and Desmeules JA (2010) Genetic polymorphisms and drug interactions modulating CYP2D6 and CYP3A activities have a major effect on oxycodone analgesic efficacy and safety. *Br J Pharmacol* **160**:919–930.
- Sami SA, Rössel P, Dimcevski G, Nielsen KD, Funch-Jensen P, Valeriani M, Arendt-Nielsen L, and Drewes AM (2006) Cortical changes to experimental sensitization of the human esophagus. *Neuroscience* **140**:269–279.
- Sandkühler J (2010) Central sensitization versus synaptic long-term potentiation (LTP): a critical comment. *J Pain* **11**:798–800.
- Sandrini G, Ruiz L, Capararo M, Garofoli F, Beretta A, and Nappi G (1992) Central analgesic activity of ibuprofen. A neurophysiological study in humans. *Int J Clin Pharmacol Res* **12**:197–204.
- Sandrini G, Serrao M, Rossi P, Romaniello A, Crucci G, and Willer JC (2005) The lower limb flexion reflex in humans. *Prog Neurobiol* **77**:353–395.
- Sarkar S, Aziz Q, Woolf CJ, Hobson AR, and Thompson DG (2000) Contribution of central sensitisation to the development of non-cardiac chest pain. *Lancet* **356**:1154–1159.
- Sarkar S, Hobson AR, Furlong PL, Woolf CJ, Thompson DG, and Aziz Q (2001) Central neural mechanisms mediating human visceral hypersensitivity. *Am J Physiol Gastrointest Liver Physiol* **281**:G1196–G1202.
- Sarkar S, Hobson AR, Hughes A, Growcott J, Woolf CJ, Thompson DG, and Aziz Q (2003) The prostaglandin E2 receptor-1 (EP-1) mediates acid-induced visceral pain hypersensitivity in humans. *Gastroenterology* **124**:18–25.
- Scanlon GC, Wallace MS, Ispirescu JS, and Schulteis G (2006) Intradermal capsaicin causes dose-dependent pain, allodynia, and hyperalgesia in humans. *J Invest Med* **54**:238–244.
- Schaffler K, Reeh PW, Zentis K, and Hamperl W (1987) Analgesic effect of acetylsalicylic acid (ASA) versus a lithium-ASA combination: an evoked potential study employing radiant heat stimulation with a CO2 laser. *Pharmacopsychiatry* **20**:217–221.
- Schmelz M and Kress M (1996) Topical acetylsalicylate attenuates capsaicin induced pain, flare and allodynia but not thermal hyperalgesia. *Neurosci Lett* **214**:72–74.
- Schmelz M, Sauerstein K, and Klede M (2000) Electrically evoked hyperalgesia in human skin. *Soc Neurosci Abstr* **27**:944.
- Scholz J and Woolf CJ (2002) Can we conquer pain? *Nat Neurosci* **5** (Suppl):1062–1067.
- Schulte H, Graven-Nielsen T, Sollevi A, Jansson Y, Arendt-Nielsen L, and Segerdahl M (2003) Pharmacological modulation of experimental phasic and tonic muscle pain by morphine, alfentanil and ketamine in healthy volunteers. *Acta Anaesthesiol Scand* **47**:1020–1030.
- Schulte H, Segerdahl M, Graven-Nielsen T, and Grass S (2006) Reduction of human experimental muscle pain by alfentanil and morphine. *Eur J Pain* **10**:733–741.
- Schulte H, Sollevi A, and Segerdahl M (2005) Dose-dependent effects of morphine on experimentally induced cutaneous pain in healthy volunteers. *Pain* **116**:366–374.
- Schulte H, Sollevi A, and Segerdahl M (2004) The synergistic effect of combined treatment with systemic ketamine and morphine on experimentally induced wind-up-like pain in humans. *Anesth Analg* **98**:1574–1580.
- Segerdahl M (2006) Multiple dose gabapentin attenuates cutaneous pain and central sensitization but not muscle pain in healthy volunteers. *Pain* **125**:158–164.
- Segerdahl M, Ekblom A, and Sollevi A (1994) The influence of adenosine, ketamine, and morphine on experimentally induced ischemic pain in healthy volunteers. *Anesth Analg* **79**:787–791.
- Sengupta JN and Gebhart GF (1994) Gastrointestinal afferent fibers and sensation, in *Physiology of the Gastrointestinal Tract* (Johnson LR ed) pp 483–519, Raven Press, New York.
- Sengupta JN, Snider A, Su X, and Gebhart GF (1999) Effects of kappa opioids in the inflamed rat colon. *Pain* **79**:175–185.
- Sengupta JN, Su X, and Gebhart GF (1996) Kappa, but not mu or delta, opioids attenuate responses to distention of afferent fibers innervating the rat colon. *Gastroenterology* **111**:968–980.
- Sethna NF, Liu M, Gracely R, Bennett GJ, and Max MB (1998) Analgesic and cognitive effects of intravenous ketamine-alfentanil combinations versus either drug alone after intradermal capsaicin in normal subjects. *Anesth Analg* **86**:1250–1256.
- Shankland WE 2nd (2011) Factors that affect pain behavior. *Cranio* **29**:144–154.
- Sharma A, Lelic D, Brock C, Paine P, and Aziz Q (2009) New technologies to investigate the brain-gut axis. *World J Gastroenterol* **15**:182–191.
- Sigtermans M, Dahan A, Mooren R, Bauer M, Kest B, Sarton E, and Olofsen E (2009) S(+)-ketamine effect on experimental pain and cardiac output: a population pharmacokinetic-pharmacodynamic modeling study in healthy volunteers. *Anesthesiology* **111**:892–903.
- Sigtermans M, Noppers I, Sarton E, Bauer M, Mooren R, Olofsen E, and Dahan A (2010) An observational study on the effect of S+ -ketamine on chronic pain versus experimental acute pain in Complex Regional Pain Syndrome type 1 patients. *Eur J Pain* **14**:302–307.
- Silos-Santiago I (2008) The role of tetrodotoxin-resistant sodium channels in pain states: are they the next target for analgesic drugs? *Curr Opin Investig Drugs* **9**:83–89.
- Simone DA, Baumann TK, and LaMotte RH (1989) Dose-dependent pain and mechanical hyperalgesia in humans after intradermal injection of capsaicin. *Pain* **38**:99–107.
- Sindrup SH, Nielsen JC, Bjerring P, and Arendt-Nielsen L (1998) Imipramine does not affect argon-laser-induced pin-prick pain thresholds and laser-evoked cerebral potentials. *Eur J Pain* **2**:127–132.
- Singler B, Tröster A, Manering N, Schüttler J, and Koppert W (2007) Modulation of remifentanyl-induced postinfusion hyperalgesia by propofol. *Anesth Analg* **104**:1397–1403.
- Siu A and Drachtman R (2007) Dextromethorphan: a review of N-methyl-D-aspartate receptor antagonist in the management of pain. *CNS Drug Rev* **13**:96–106.
- Slater H, Gibson W, and Graven-Nielsen T (2011) Sensory responses to mechanically and chemically induced tendon pain in healthy subjects. *Eur J Pain* **15**:146–152.
- Smith BH, Elliott AM, Chambers WA, Smith WC, Hannaford PC, and Penny K (2001) The impact of chronic pain in the community. *Fam Pract* **18**:292–299.
- Smith GM, Egbert LD, Markowitz RA, Mosteller F, and Beecher HK (1966) An experimental pain method sensitive to morphine in man: the submaximum effort tourniquet technique. *J Pharmacol Exp Ther* **154**:324–332.
- Smith JK, Humes DJ, Head KE, Bush D, White TP, Stevenson CM, Brookes MJ, Marciani L, Spiller RC, Gowland PA, et al. (2011) fMRI and MEG analysis of visceral pain in healthy volunteers. *Neurogastroenterol Motil* **23**:e648–e260.
- Sörensen J, Bengtsson A, Ahlner J, Henriksson KG, Ekselius L, and Bengtsson M (1997) Fibromyalgia—are there different mechanisms in the processing of pain? A double blind crossover comparison of analgesic drugs. *J Rheumatol* **24**:1615–1621.
- Sörensen J, Bengtsson A, Bäckman E, Henriksson KG, and Bengtsson M (1995) Pain analysis in patients with fibromyalgia. Effects of intravenous morphine, lidocaine, and ketamine. *Scand J Rheumatol* **24**:360–365.
- Sprenker C, Bingel U, and Büchel C (2011) Treating pain with pain: supraspinal mechanisms of endogenous analgesia elicited by heterotopic noxious conditioning stimulation. *Pain* **152**:428–439.
- Sprenker T, Valet M, Boecker H, Henriksen G, Spilker ME, Willoch F, Wagner KJ, Wester HJ, and Tölle TR (2006) Opioidergic activation in the medial pain system after heat pain. *Pain* **122**:63–67.
- Srinivasan V, Wielbo D, and Tebbitt IR (1997) Analgesic effects of codeine-6-glucuronide after intravenous administration. *Eur J Pain* **1**:185–190.
- Staaal C, Christrup LL, Andersen SD, Arendt-Nielsen L, and Drewes AM (2006a) A comparative study of oxycodone and morphine in a multi-modal, tissue-differentiated experimental pain model. *Pain* **123**:28–36.
- Staaal C, Dimcevski G, Andersen SD, Thorsgaard N, Christrup LL, Arendt-Nielsen L, and Drewes AM (2007) Differential effect of opioids in patients with chronic pancreatitis: an experimental pain study. *Scand J Gastroenterol* **42**:383–390.
- Staaal C and Drewes AM (2004) Experimental human pain models: a review of standardised methods for preclinical testing of analgesics. *Basic Clin Pharmacol Toxicol* **95**:97–111.
- Staaal C, Krarup AL, Olesen AE, Brock C, Graversen C, and Drewes AM (2011) Is electrical brain activity a reliable biomarker for opioid analgesia in the gut? *Basic Clin Pharmacol Toxicol* **109**:321–327.
- Staaal C, Olesen AE, Andresen T, Arendt-Nielsen L, and Drewes AM (2009a) Assessing analgesic actions of opioids by experimental pain models in healthy volunteers - an updated review. *Br J Clin Pharmacol* **68**:149–168.
- Staaal C, Olesen AE, Andresen T, Arendt-Nielsen L, and Drewes AM (2009b) Assessing efficacy of non-opioid analgesics in experimental pain models in healthy volunteers: an updated review. *Br J Clin Pharmacol* **68**:322–341.
- Staaal C, Reddy H, Andersen SD, Arendt-Nielsen L, and Drewes AM (2006b) Multi-modal and tissue-differentiated experimental pain assessment: reproducibility of a new concept for assessment of analgesics. *Basic Clin Pharmacol Toxicol* **98**:201–211.
- Stacey MJ (1969) Free nerve endings in skeletal muscle of the cat. *J Anat* **105**:231–254.
- Stacher G, Bauer P, Schneider C, Winklehner S, and Schmierer G (1982) Effects of a combination of oral naproxen sodium and codeine on experimentally induced pain. *Eur J Clin Pharmacol* **21**:485–490.
- Stacher G, Steinringer H, Winklehner S, Mittelbach G, and Schneider C (1983) Effects of graded oral doses of meptazinol and pentazocine in comparison with placebo on experimentally induced pain in healthy humans. *Br J Clin Pharmacol* **16**:149–156.
- Stanfa L and Dickenson A (1995) Spinal opioid systems in inflammation. *Inflamm Res* **44**:231–241.
- Staud R, Cannon RC, Mauderli AP, Robinson ME, Price DD, and Vierck CJ Jr (2003) Temporal summation of pain from mechanical stimulation of muscle tissue in normal controls and subjects with fibromyalgia syndrome. *Pain* **102**:87–95.
- Staud R, Vierck CJ, Robinson ME, and Price DD (2005) Effects of the N-methyl-D-aspartate receptor antagonist dextromethorphan on temporal summation of pain are similar in fibromyalgia patients and normal control subjects. *J Pain* **6**:323–332.
- Steen KH, Issberner U, and Reeh PW (1995) Pain due to experimental acidosis in human skin: evidence for non-adapting nociceptor excitation. *Neurosci Lett* **199**:29–32.
- Steen KH and Reeh PW (1993) Sustained graded pain and hyperalgesia from harmless experimental tissue acidosis in human skin. *Neurosci Lett* **154**:113–116.
- Steen KH, Reeh PW, and Kreysel HW (1996) Dose-dependent competitive block by topical acetylsalicylic and salicylic acid of low pH-induced cutaneous pain. *Pain* **64**:71–82.
- Stein C (1993) Peripheral mechanisms of opioid analgesia. *Anesth Analg* **76**:182–191.
- Stein C, Cabot PJ, and Schafer M (1999) Peripheral opioid analgesia: mechanisms

- and clinical implications, in *Opioids in Pain Control* (Stein C ed) pp 96–108, Cambridge University Press, Cambridge.
- Straube S, Derry S, McQuay HJ, and Moore RA (2008) Enriched enrollment: definition and effects of enrichment and dose in trials of pregabalin and gabapentin in neuropathic pain. A systematic review. *Br J Clin Pharmacol* **66**:266–275.
- Strigo IA, Duncan GH, Bushnell MC, Bovin M, Wainer I, Rodriguez Rosas ME, and Persson J (2005) The effects of racemic ketamine on painful stimulation of skin and viscera in human subjects. *Pain* **113**:255–264.
- Svensden KB, Jensen TS, and Bach FW (2004) Does the cannabinoid dronabinol reduce central pain in multiple sclerosis? Randomised double blind placebo controlled crossover trial. *BMJ* **329**:253.
- Svensson P, Arendt-Nielsen L, Nielsen H, and Larsen JK (1995) Effect of chronic and experimental jaw muscle pain on pain-pressure thresholds and stimulus-response curves. *J Orofac Pain* **9**:347–356.
- Svensson P, Cairns BE, Wang K, and Arendt-Nielsen L (2003a) Injection of nerve growth factor into human masseter muscle evokes long-lasting mechanical allodynia and hyperalgesia. *Pain* **104**:241–247.
- Svensson P, Cairns BE, Wang K, Hu JW, Graven-Nielsen T, Arendt-Nielsen L, and Sessle BJ (2003b) Glutamate-evoked pain and mechanical allodynia in the human masseter muscle. *Pain* **101**:221–227.
- Svensson P, Houe L, and Arendt-Nielsen L (1997) Effect of systemic versus topical nonsteroidal anti-inflammatory drugs on postexercise jaw-muscle soreness: a placebo-controlled study. *J Orofac Pain* **11**:353–362.
- Svensson P, Wang K, Arendt-Nielsen L, and Cairns BE (2008) Effects of NGF-induced muscle sensitization on proprioception and nociception. *Exp Brain Res* **189**:1–10.
- Sycha T, Gustorff B, Lehr S, Tanew A, Eichler HG, and Schmetterer L (2003) A simple pain model for the evaluation of analgesic effects of NSAIDs in healthy subjects. *Br J Clin Pharmacol* **56**:165–172.
- Tegeer I, Meier S, Burian M, Schmidt H, Geisslinger G, and Lötsch J (2003) Peripheral opioid analgesia in experimental human pain models. *Brain* **126**:1092–1102.
- Terman GW and Bonica JJ (2001) Spinal mechanisms and their modulation, in *Bonica's Management of Pain* (Loeser JD ed) pp 73–152, Lippincott Williams & Wilkins, Philadelphia.
- Thumshirn M, Coulie B, Camilleri M, Zinsmeister AR, Burton DD, and Van Dyke C (2000) Effects of alosetron on gastrointestinal transit time and rectal sensation in patients with irritable bowel syndrome. *Aliment Pharmacol Ther* **14**:869–878.
- Thürauf N, Fleischer WK, Liefhold J, Schmid O, and Kobal G (1996) Dose dependent time course of the analgesic effect of a sustained-release preparation of tramadol on experimental phasic and tonic pain. *Br J Clin Pharmacol* **41**:115–123.
- Tian YL, Guo Y, Cao DY, Zhang Q, Wang HS, and Zhao Y (2005) Local application of morphine suppresses glutamate-evoked activities of C and Adelta afferent fibers in rat hairy skin. *Brain Res* **1059**:28–34.
- Todd AJ, McGill MM, and Shehab SA (2000) Neurokinin 1 receptor expression by neurons in laminae I, III and IV of the rat spinal dorsal horn that project to the brainstem. *Eur J Neurosci* **12**:689–700.
- Treede RD, Jensen TS, Campbell JN, Cruccu G, Dostrovsky JO, Griffin JW, Hansson P, Hughes R, Nurmikko T, and Serra J (2008) Neuropathic pain: redefinition and a grading system for clinical and research purposes. *Neurology* **70**:1630–1635.
- Treede RD, Meyer RA, Raja SN, and Campbell JN (1992) Peripheral and central mechanisms of cutaneous hyperalgesia. *Prog Neurobiol* **38**:397–421.
- Treister R, Eisenberg E, Gershon E, Haddad M, and Pud D (2010) Factors affecting - and relationships between-different modes of endogenous pain modulation in healthy volunteers. *Eur J Pain* **14**:608–614.
- Trescot AM, Boswell MV, Atluri SL, Hansen HC, Deer TR, Abdi S, Jasper JF, Singh V, Jordan AE, Johnson BW, et al. (2006) Opioid guidelines in the management of chronic non-cancer pain. *Pain Physician* **9**:1–39.
- Trescot AM, Datta S, Lee M, and Hansen H (2008) Opioid pharmacology. *Pain Physician* **11** (2 Suppl):S133–S153.
- Tröster A, Sittl R, Singler B, Schmelz M, Schüttler J, and Koppert W (2006) Modulation of remifentanyl-induced analgesia and postinfusion hyperalgesia by parecoxib in humans. *Anesthesiology* **105**:1016–1023.
- Tucker AP, Kim YI, Nadeson R, and Goodchild CS (2005) Investigation of the potentiation of the analgesic effects of fentanyl by ketamine in humans: a double-blind, randomised, placebo controlled, crossover study of experimental pain [ISRCTN83088383]. *BMC Anesthesiol* **5**:2.
- Tzabazis AZ, Klukin M, Crottaz-Herbette S, Nemenov MI, Angst MS, and Yeomans DC (2011) Selective nociceptor activation in volunteers by infrared diode laser. *Mol Pain* **7**:18.
- van den Elzen BD, Tytgat GN, and Boeckstaens GE (2009) Gastric hypersensitivity induced by oesophageal acid infusion in healthy volunteers. *Neurogastroenterol Motil* **21**:160–169.
- van der Burght M, Rasmussen SE, Arendt-Nielsen L, and Bjerring P (1994) Morphine does not affect laser induced warmth and pin prick pain thresholds. *Acta Anaesthesiol Scand* **38**:161–164.
- van der Schaar PJ, Lamers CB, and Masclée AA (1999) The role of the barostat in human research and clinical practice. *Scand J Gastroenterol Suppl* **230**:52–63.
- Vatine JJ, Shapira SC, Magora F, Adler D, and Magora A (1993) Electronic pressure algometry of deep pain in healthy volunteers. *Arch Phys Med Rehabil* **74**:526–530.
- Vecchiet L, Marini I, and Feroldi P (1983) Muscular pain caused by isometric contraction: evaluation of pain through visual analog scale. *Clin Ther* **5**:504–508.
- Verne GN and Price DD (2002) Irritable bowel syndrome as a common precipitant of central sensitization. *Curr Rheumatol Rep* **4**:322–328.
- Villanova N, Azpiroz F, and Malagelada JR (1997) Perception and gut reflexes induced by stimulation of gastrointestinal thermoreceptors in humans. *J Physiol* **502**:215–222.
- Wagner KJ, Sprenger T, Kochs EF, Tölle TR, Valet M, and Willloch F (2007) Imaging human cerebral pain modulation by dose-dependent opioid analgesia: a positron emission tomography activation study using remifentanyl. *Anesthesiology* **106**:548–556.
- Walker DJ and Zacny JP (1998) Subjective, psychomotor, and analgesic effects of oral codeine and morphine in healthy volunteers. *Psychopharmacology (Berl)* **140**:191–201.
- Walker JS (2003) Anti-inflammatory effects of opioids. *Adv Exp Med Biol* **521**:148–160.
- Wallace M, Schulteis G, Atkinson JH, Wolfson T, Lazzaretto D, Bentley H, Gouaux B, and Abramson I (2007) Dose-dependent effects of smoked cannabis on capsaicin-induced pain and hyperalgesia in healthy volunteers. *Anesthesiology* **107**:785–796.
- Wallace MS, Braun J, and Schulteis G (2002a) Postdelivery of alfentanil and ketamine has no effect on intradermal capsaicin-induced pain and hyperalgesia. *Clin J Pain* **18**:373–379.
- Wallace MS, Quessy S, and Schulteis G (2004) Lack of effect of two oral sodium channel antagonists, lamotrigine and 4030W92, on intradermal capsaicin-induced hyperalgesia model. *Pharmacol Biochem Behav* **78**:349–355.
- Wallace MS, Ridgeway B 3rd, Leung A, Schulteis G, and Yaksh TL (2002b) Concentration-effect relationships for intravenous alfentanil and ketamine infusions in human volunteers: effects on acute thresholds and capsaicin-evoked hyperpathia. *J Clin Pharmacol* **42**:70–80.
- Wallace MS and Schulteis G (2008) Effect of chronic oral gabapentin on capsaicin-induced pain and hyperalgesia: a double-blind, placebo-controlled, crossover study. *Clin J Pain* **24**:544–549.
- Warnecke T, Stubhaug A, and Jørum E (1997) Ketamine, an NMDA receptor antagonist, suppresses spatial and temporal properties of burn-induced secondary hyperalgesia in man: a double-blind, cross-over comparison with morphine and placebo. *Pain* **72**:99–106.
- Webb J and Kamali F (1998) Analgesic effects of lamotrigine and phenytoin on cold-induced pain: a crossover placebo-controlled study in healthy volunteers. *Pain* **76**:357–363.
- Wehrfritz AP, Ihmsen H, Schmidt S, Müller C, Filitz J, Schüttler J, and Koppert W (2010) Interaction of physostigmine and alfentanil in a human pain model. *Br J Anaesth* **104**:359–368.
- Weidner C, Schmelz M, Schmidt R, Hansson B, Handwerker HO, and Torebjörk HE (1999) Functional attributes discriminating mechano-insensitive and mechano-responsive C nociceptors in human skin. *J Neurosci* **19**:10184–10190.
- Welch JM, Simon SA, and Reinhart PH (2000) The activation mechanism of rat vanilloid receptor 1 by capsaicin involves the pore domain and differs from the activation by either acid or heat. *Proc Natl Acad Sci USA* **97**:13889–13894.
- Wilder-Smith CH, Hill L, Dyer RA, Torr G, and Coetzee E (2003a) Postoperative sensitization and pain after cesarean delivery and the effects of single im doses of tramadol and diclofenac alone and in combination. *Anesth Analg* **97**:526–533.
- Wilder-Smith CH, Hill L, Osler W, and O'Keefe S (1999a) Effect of tramadol and morphine on pain and gastrointestinal motor function in patients with chronic pancreatitis. *Dig Dis Sci* **44**:1107–1116.
- Wilder-Smith CH, Hill L, Spargo K, and Kalla A (2001) Treatment of severe pain from osteoarthritis with slow-release tramadol or dihydrocodeine in combination with NSAID's: a randomised study comparing analgesia, antinociception and gastrointestinal effects. *Pain* **91**:23–31.
- Wilder-Smith CH, Hill L, Wilkins J, and Denny L (1999b) Effects of morphine and tramadol on somatic and visceral sensory function and gastrointestinal motility after abdominal surgery. *Anesthesiology* **91**:639–647.
- Wilder-Smith CH, Schindler D, Lovblad K, Redmond SM, and Nirikko A (2004) Brain functional magnetic resonance imaging of rectal pain and activation of endogenous inhibitory mechanisms in irritable bowel syndrome patient subgroups and healthy controls. *Gut* **53**:1595–1601.
- Wilder-Smith OH, Arendt-Nielsen L, Gäumann D, Tassonyi E, and Rifat KR (1998) Sensory changes and pain after abdominal hysterectomy: a comparison of anesthetic supplementation with fentanyl versus magnesium or ketamine. *Anesth Analg* **86**:95–101.
- Wilder-Smith OH, Tassonyi E, Crul BJ, and Arendt-Nielsen L (2003b) Quantitative sensory testing and human surgery: effects of analgesic management on postoperative neuroplasticity. *Anesthesiology* **98**:1214–1222.
- Wilder-Smith OH, Tassonyi E, Senly C, Otten P, and Arendt-Nielsen L (1996) Surgical pain is followed not only by spinal sensitization but also by supraspinal antinociception. *Br J Anaesth* **76**:816–821.
- Willer JC (1977) Comparative study of perceived pain and nociceptive flexion reflex in man. *Pain* **3**:69–80.
- Willer JC, Le Bars D, and De Broucker T (1990) Diffuse noxious inhibitory controls in man: involvement of an opioidergic link. *Eur J Pharmacol* **182**:347–355.
- Willert RP, Delaney C, Kelly K, Sharma A, Aziz Q, and Hobson AR (2007) Exploring the neurophysiological basis of chest wall allodynia induced by experimental oesophageal acidification - evidence of central sensitization. *Neurogastroenterol Motil* **19**:270–278.
- Willert RP, Woolf CJ, Hobson AR, Delaney C, Thompson DG, and Aziz Q (2004) The development and maintenance of human visceral pain hypersensitivity is dependent on the N-methyl-D-aspartate receptor. *Gastroenterology* **126**:683–692.
- Willis WD (2001) Role of neurotransmitters in sensitization of pain responses. *Ann NY Acad Sci* **933**:142–156.
- Willloch F, Gamminger U, Medele R, Steude U, Tölle TR, and PET activation study (2003) Analgesia by electrostimulation of the trigeminal ganglion in patients with trigeminal neuropathic pain: a PET activation study. *Pain* **103**:119–130.
- Witting N, Svensson P, Gottrup H, Arendt-Nielsen L, and Jensen TS (2000) Intramuscular and intradermal injection of capsaicin: a comparison of local and referred pain. *Pain* **84**:407–412.
- Wood JD, Alpers DH, and Andrews PL (1999) Fundamentals of neurogastroenterology. *Gut* **45** (Suppl 2):II6–II16.
- Woolf CJ (2011) Central sensitization: implications for the diagnosis and treatment of pain. *Pain* **152**:S2–15.

- Woolf CJ and Mannion RJ (1999) Neuropathic pain: aetiology, symptoms, mechanisms, and management. *Lancet* **353**:1959–1964.
- Xie YF, Huo FQ, and Tang JS (2009) Cerebral cortex modulation of pain. *Acta Pharmacol Sin* **30**:31–41.
- Yarnitsky D (2010) Conditioned pain modulation (the diffuse noxious inhibitory control-like effect): its relevance for acute and chronic pain states. *Curr Opin Anaesthesiol* **23**:611–615.
- Yoburn BC, Lutfy K, and Candido J (1991) Species differences in mu- and delta-opioid receptors. *Eur J Pharmacol* **193**:105–108.
- Zamponi GW, Lewis RJ, Todorovic SM, Arneric SP, and Snutch TP (2009) Role of voltage-gated calcium channels in ascending pain pathways. *Brain Res Rev* **60**:84–89.
- Zigheboim J, Talley NJ, Phillips SF, Harmsen WS, and Zinsmeister AR (1995) Visceral perception in irritable bowel syndrome. Rectal and gastric responses to distension and serotonin type 3 antagonism. *Dig Dis Sci* **40**:819–827.
- Zwisler ST, Enggaard TP, Noehr-Jensen L, Mikkelsen S, Verstuyft C, Becquemont L, Sindrup SH, and Broesen K (2010) The antinociceptive effect and adverse drug reactions of oxycodone in human experimental pain in relation to genetic variations in the OPRM1 and ABCB1 genes. *Fundam Clin Pharmacol* **24**:517–524.
- Zwisler ST, Enggaard TP, Noehr-Jensen L, Pedersen RS, Mikkelsen S, Nielsen F, Broesen K, and Sindrup SH (2009) The hypoalgesic effect of oxycodone in human experimental pain models in relation to the CYP2D6 oxidation polymorphism. *Basic Clin Pharmacol Toxicol* **104**:335–344.